



SCDF
The Life Saving Force

Building and Construction Authority
We shape a **safe**, **high quality**, **sustainable** and **friendly** built environment.



TECHNICAL REQUIREMENTS FOR HOUSEHOLD SHELTERS 2017



CONTENTS

All rights reserved. No part of this publication may be reproduced, stored in a retrieval system, or transmitted in any form or by any means, electronic, mechanical, photocopying, recording or otherwise, without the prior permission of the SCDF and BCA.

First Issued - November 2017
Updated - June 2018

TABLE OF CONTENTS

CHAPTER 1 : INTRODUCTION

1.1	GENERAL	1
1.2	APPLICATION OF HS TECHNICAL REQUIREMENTS	1
1.3	PEACETIME USE	1
1.4	ABBREVIATIONS.....	1
1.5	DEFINITIONS.....	2

CHAPTER 2 : ARCHITECTURAL REQUIREMENTS

2.1	HS OR NS FORM	3
2.2	SIZE OF HS	3
221	Area and Volume	3
222	Heights	3
2.3	WALL AND SLAB THICKNESS OF HS AND NS.....	3
231	Wall Thickness of HS and NS	3
232	Slab Thickness of HS and Enclosed NS	4
233	Slab Thickness of HS and Non-Enclosed NS.....	4
2.4	LOCATION OF HS	5
241	HS Position	5
242	HS Tower	5
243	Setback Distances of HS Walls (Without Reinforced Concrete Down-hang Beams along EBL)	5
244	Setback Distances of HS Walls (With Reinforced Concrete Down-hang Beams along EBL)	6
245	Full Height Shielding Walls to HS Wall (without HS Door).....	6
246	Setback Distances of Basement HS	7
247	RC Lift Core or/and Refuse Chute or/and Service Riser located within Setback Distance of HS	8
2.5	HS DOOR.....	8
251	Dimensions.....	8
252	Door Frame.....	8
253	Strengthened Ceiling Slab Outside HS Door and HS Walls	9
2.6	PRECAST HOLLOW CORE HOUSEHOLD SHELTERS (PRECAST HS).....	9
261	Design of Precast Hollow Core Household Shelters (Precast HS).....	9
262	Dimensions.....	9
2.7	FIXTURES IN HS	10
271	General.....	10
272	Power Points	10
273	Light Fittings	10

274	Cable Entries and Openings	10
2.8	NS IN HS TOWER.....	11
281	Aggregate Wall Heights of NS	11
282	Shielded and Unshielded NS Walls/Columns	11
2.9	TRANSFER STRUCTURE SUPPORTING HS TOWER.....	11
291	General.....	11
292	Transfer Structure	12
2.10	HS BENEATH AN INTERNAL STAIRCASE	12
2.11	FINISHES IN HS.....	12
2.12	EXIT STAIRCASE	12
2.13	DOOR RECESS ON HS WALL.....	13
	LIST OF TABLES/FIGURES	14 - 66

CHAPTER 3 : STRUCTURAL REQUIREMENTS

3.1	GENERAL	67
3.2	MATERIALS.....	67
321	Concrete	67
322	Steel Reinforcement	67
3.3	ANALYSIS.....	67
331	General.....	67
332	Beam Supported by HS wall.....	67
333	Shielded NS walls and/or NS columns	67
334	Unshielded NS Wall(s) and/or NS Columns	68
335	Transfer Structure Supporting HS Tower	69
3.3.5.1	Design against Collapse Load.....	69
3.3.5.2	Shielded Transfer Structure	69
3.3.5.3	Unshielded Transfer Structure.....	69
3.4	MEMBER DIMENSIONS AND REINFORCEMENT REQUIREMENTS	70
341	Member Dimensions	70
342	Reinforcement Requirements	70
3.4.2.1	Wall Reinforcements of HS and NS.....	70
3.4.2.2	Slab Reinforcements of HS and NS.....	71
3.4.2.3	Ceiling Slab Immediately Outside the HS.....	71
3.4.2.4	HS Slab Which Is Integrated With Pile-Cap/ Footing	71
3.4.2.5	Reinforcement Bar Details of Precast Shielding Wall for HS Wall.....	71
3.5	DETAILING OF HS TOWER.....	71
351	General.....	71
352	Lap and Anchorage Length	72
353	Concrete Cover.....	72
354	Cast-In-Situ Elements.....	72
355	Precast HS Door Frame Panel.....	72

356	Precast HS Hollow Core.....	73
357	Joints	75
3.6	PENETRATION OF SERVICES	76
361	Electrical Services	76
362	Water and Gas Services.....	76
363	Refuse Chute or/ and Services Risers within the setback distance of HS.....	76
	LIST OF TABLES/FIGURES	77 - 145

CHAPTER 4 : VENTILATION SLEEVES

4.1	GENERAL	146
4.2	POSITION.....	146
4.3	ACCESSIBILITY OF VENTILATION SLEEVES.....	146
431	Clearance in front of and around Fragmentation Plate.....	146
432	False Ceiling below Ventilation Sleeves	146
4.4	FRAGMENTATION PLATE	147
	LIST OF TABLES/FIGURES	148 - 152

CHAPTER 5 : HS DOOR

5.1	GENERAL	153
5.2	APPROVED HS DOOR.....	153
5.3	HS DOOR NOTICE	153
5.4	SPECIFICATION OF HS DOOR NOTICE.....	153
	LIST OF TABLES/FIGURES	154 - 155

CHAPTER 6 : CONSTRUCTION AND COMMISSIONING

6.1	GENERAL	156
6.2	STRUCTURAL WORKS	156
6.3	HS DOOR.....	157
6.4	PEACETIME REQUIREMENT OF VENTILATION SLEEVES	157
6.5	COMMISSIONING REQUIREMENTS.....	157

CHAPTER 7 : PERMITTED AND NOT PERMITTED WORKS TO HS TOWER

7.1	GENERAL	159
7.2	PERMITTED AND NOT PERMITTED WORKS	159

721	Permitted Works to HS	159
722	Not Permitted Works to HS	160
723	Not Permitted Works to NS	161

LIST OF TABLES (CHAPTER 2)

TABLE 2.2.1 (b)	MINIMUM INTERNAL HS FLOOR AREA AND VOLUME	15
TABLE 2.2.1 (c)	NUMBER OF SQUARE UNITS (0.6m x 0.6m) USED FOR THE ASSESSMENT OF TRAPEZOIDAL OR L-SHAPED HS	15
TABLE 2.3.1(a)	MINIMUM HS AND NS WALL THICKNESS (FOR LANDED DEVELOPMENTS)	18
TABLE 2.3.1(b)	MINIMUM HS AND NS WALL THICKNESS (FOR NON-LANDED DEVELOPMENTS)	19
TABLE 2.4.3(a)	MINIMUM SETBACK DISTANCES OF HS WALLS WITHOUT REINFORCED CONCRETE DOWN-HANG BEAM ALONG EBL	29
TABLE 2.4.4(a)	MINIMUM SETBACK DISTANCES OF HS WALLS WITH REINFORCED CONCRETE DOWN-HANG BEAM ALONG EBL	33
TABLE 2.4.6(a)	MINIMUM SETBACK DISTANCES OF BASEMENT HS WALLS (FACING REINFORCED CONCRETE BASEMENT STOREY WALLS WITH OPENING)	43

LIST OF FIGURES (CHAPTER 2)

FIGURE 2.2.1(a)	EXAMPLES OF HS OF DIFFERENT SHAPES	14
FIGURE 2.2.2(a)	HS CLEAR HEIGHT IN NON-LANDED AND LANDED DEVELOPMENTS	16
FIGURE 2.2.2(b)	SECTION OF HS TOWER SHOWING HS AND NS CLEAR HEIGHTS	17
FIGURE 2.3.1(c)	INTERNAL COMMON WALL BETWEEN TWO HS IN NON-LANDED AND LANDED CLUSTER HOUSING DEVELOPMENTS	20
FIGURE 2.3.1(d)	SEPARATE WALLS BETWEEN TWO HS IN INTERMEDIATE LANDED DEVELOPMENTS	21
FIGURE 2.3.2	HS TOWER SHOWING HS AND NS (WITH ENCLOSED AND NON-ENCLOSED NS WALL) SLAB THICKNESS ..	22
FIGURE 2.3.2(f)	MINIMUM DIMENSIONS OF CEILING SLAB FOR HS IN LANDED DEVELOPMENT	23
FIGURE 2.4.1(b)	HS WALL ABUTTING AN AIR WELL IN A LANDED DEVELOPMENT	24
FIGURE 2.4.1c(i)	RC/CLAY TILED ROOF COVER OVER STAIRCASE NEAR HS WALL IN A LANDED DEVELOPMENT	25

FIGURE 2.4.1c(ii)	RC/CLAY TILED ROOF COVER OVER STAIRCASE (WITH VOID) NEAR HS WALL IN A LANDED DEVELOPMENT	26
FIGURE 2.4.2(a)	SCHEMATIC SECTION OF HS TOWER	27
FIGURE 2.4.2(b)	HS TOWER WITH LARGER HS BELOW MAIN ROOF LEVEL	28
FIGURE 2.4.3a(i)	REQUIREMENT ON SETBACK DISTANCE OF HS WALL (WITHOUT DOWN-HANG BEAM)	30
FIGURE 2.4.3a(ii)	SETBACK DISTANCE OF HS WALLS (WITHOUT DOWN-HANG BEAM)	31
FIGURE 2.4.3(c)	USAGE OF TRELLIS (RC/STEEL HOLLOW SECTIONS) TO MAKE UP FOR SHORTFALL IN SETBACK DISTANCE	32
FIGURE 2.4.4(a)	REQUIREMENT ON SETBACK DISTANCE OF HS WALLS (WITH DOWN-HANG BEAM)	34
FIGURE 2.4.4(b)	DOWN-HANG BEAM LOCATED AWAY FROM EXTERNAL BUILDING LINE	35
FIGURE 2.4.5(a)	SHIELDING WALL “A” AND “B” FOR HS WITH SHORTFALL OF SETBACK DISTANCE ON ONE SIDE OF HS (TYPE 1A)	36
FIGURE 2.4.5(b)	SHIELDING WALL “A” AND “B” FOR HS WITH SHORTFALL OF SETBACK DISTANCE ON ONE SIDE OF HS (TYPE 1B)	37
FIGURE 2.4.5(c)	SHIELDING WALL “A” AND “B” FOR HS WITH SHORTFALL OF SETBACK DISTANCE ON ONE SIDE OF HS (TYPE 1C)	38
FIGURE 2.4.5(d)	SHIELDING WALL “A” AND “B” FOR HS WITH SHORTFALL OF SETBACK DISTANCE ON TWO SIDES OF HS (TYPE 2A)	39
FIGURE 2.4.5(e)	SHIELDING WALL “A” AND “B” FOR HS WITH SHORTFALL OF SETBACK DISTANCE ON TWO SIDES OF HS (TYPE 2B)	40
FIGURE 2.4.5(f)	SHIELDING WALL “C” AND “D” FOR HS WITH SHORTFALL OF SETBACK DISTANCE AT ONE CORNER OF HS (TYPE 3A)	41
FIGURE 2.4.5(g)	SHIELDING WALL “C” AND “E” FOR HS WITH SHORTFALL OF SETBACK DISTANCE AT ONE CORNER OF HS (TYPE 3B)	42
FIGURE 2.4.6(a)	PLAN OF A BASEMENT HS	44
FIGURE 2.4.6(b)	PLAN OF A BASEMENT HS (WITH HS DOOR FACES RC BASEMENT WALL)	44
FIGURE 2.4.6(c)	SECTIONAL VIEW OF A BASEMENT HS	45

FIGURE 2.4.7a	HS LOCATED NEXT TO LIFT SHAFT	46
FIGURE 2.4.7b(i)	PROTECTION REQUIREMENT AT ROOF LEVEL FOR PROVISION OF RC REFUSE CHUTE LOCATED WITHIN SETBACK DISTANCE ENVELOP	47
FIGURE 2.4.7b(ii)	REQUIREMENTS FOR PROTRUDING OF REFUSE CHUTE ABOVE THE ROOF	48
FIGURE 2.4.7c(i)	REQUIREMENTS FOR PROTRUDING OF RISER ABOVE THE ROOF (TYPE A)	49
FIGURE 2.4.7c(ii)	REQUIREMENTS FOR PROTRUDING OF RISER ABOVE THE ROOF (TYPE B)	50
FIGURE 2.4.7c(iii)	RISER ADJACENT TO HS WITH PROJECTION ABOVE MAIN ROOF LEVEL	51
FIGURE 2.4.7c(iv)	RISER ADJACENT TO HS WITH PROJECTION ABOVE MAIN ROOF LEVEL	52
FIGURE 2.4.7c(v)	RISER ADJACENT TO HS WITH PROJECTION ABOVE MAIN ROOF LEVEL	53
FIGURE 2.5.1(a)	HS DOOR FRAME WITH SINGLE DOOR REBATE	54
FIGURE 2.5.1(b)	HS DOOR FRAME WITH DOUBLE DOOR REBATES ...	54
FIGURE 2.5.2(a)	CONCRETE WALL SEGMENT AT HS DOOR	55
FIGURE 2.5.2(e)	HS DOOR KERB	55
FIGURE 2.5.3	REQUIREMENTS FOR STRENGTHENED CEILING SLAB IN FRONT OF HS DOOR IN NON-LANDED DEVELOPMENT	56
FIGURE 2.6.1(a)	PRECAST HS WITH HS DOOR ON LONGER WALL AND ONE OF VENTILATION SLEEVES ABOVE THE DOOR	57
FIGURE 2.6.1(b)	PRECAST HS AND C-SHAPED PRECAST HS CONNECTED AT THE SHORTER WALL AND WITH HS DOOR ON LONGER WALLS	57
FIGURE 2.6.1(c)	PRECAST HS AND C-SHAPED PRECAST HS CONNECTED AT THE LONGER WALL AND WITH HS DOOR ON LONGER WALLS	58
FIGURE 2.6.1(d)	PRECAST HS AND C-SHAPED PRECAST HS WITH CONNECTION BETWEEN LONGER AND SHORTER WALLS RESPECTIVELY AND WITH HS DOORS ON LONG WALL	58
FIGURE 2.6.1(e)	PRECAST HS ADJOINING CAST IN-SITU WALLS/COLUMNS	59
FIGURE 2.6.2(c)	PRECAST HS DIMENSIONS	59
FIGURE 2.6.2(f)	SHEAR KEY ON WALL ABOVE HS DOOR	60
FIGURE 2.7.1(c)	FIXTURES IN HS	61

FIGURE 2.8.1(a)	HS TOWER	62
FIGURE 2.9.1(a)	SHIELDING OF TRANSFER STRUCTURES SUPPORTING HS TOWER	63
FIGURE 2.9.1(b)	SHIELDING OF TRANSFER SLAB/BEAMS/EXTERIOR COLUMNS/WALLS	64
FIGURE 2.10	HS BENEATH AN INTERNAL STAIRCASE	65
FIGURE 2.13	DETAILS OF WALL RECESS FOR HS DOOR HANDLE	66

LIST OF TABLES (CHAPTER 3)

TABLE 3.3.4 (d):	ACTION COMBINATION AND VALUES OF PARTIAL SAFETY FACTORS (γ_f) FOR ULTIMATE LIMIT STATE.....	79
TABLE 3.3.5.1:	DESIGN VALUES OF ACTIONS OF PARTIAL SAFETY FACTORS (γ_f) FOR ULTIMATE LIMIT STATE	79
TABLE 3.4.2.1(a):	MINIMUM REINFORCEMENT OF HS WALLS FOR LANDED DEVELOPMENTS.....	84
TABLE 3.4.2.1(b):	MINIMUM REINFORCEMENT OF HS AND NS WALLS FOR NON-LANDED DEVELOPMENTS.....	84
TABLE 3.5.2(a):	LAP AND ANCHORAGE LENGTHS(CONCRETE GRADE C25/30 FOR LANDED DEVELOPMENTS)	85
TABLE 3.5.2(b):	LAP AND ANCHORAGE LENGTHS (CONCRETE GRADE C32/40 FOR LANDED AND NON-LANDED DEVELOPMENTS)	85
TABLE 3.5.6(a):	DIMENSION OF PRECAST HOLLOW CORES HS	109
TABLE 3.5.6(b):	HS WALL THICKNESS AND SIZES OF HOLLOW CORES	109
TABLE 3.5.6(c):	MINIMUM REINFORCEMENT BARS IN HOLLOW CORES	110
TABLE 3.5.6(d):	MINIMUM THICKNESS OF SLAB AND REINFORCED CONCRETE TOPPING	110

LIST OF FIGURES (CHAPTER 3)

FIGURE 3.3.3	SHIELDED NS WALLS AND/OR NS COLUMNS	77
FIGURE 3.3.4(a)	UNSHIELD NS WALL(S)	78
FIGURE 3.3.4(b)	UNSHIELD NS COLUMN(S)	78
FIGURE 3.3.4(c)	COMBINATION OF UNSHIELD NS WALL(S) AND/OR NS COLUMN(S)	78

FIGURE 3.3.5.2(a)	SHIELDED TRANSFER SYSTEM THAT SUPPORTS HS TOWER	80
FIGURE 3.3.5.3	UNSHIELDED TRANSFER SYSTEM THAT SUPPORTS HS TOWER (UNSHIELDED SLAB/BEAM OR/AND COLUMNS/WALLS)	81
FIGURE 3.3.5.3a(i)	UNSHIELDED TRANSFER BEAMS	82
FIGURE 3.3.5.3a(ii)	UNSHIELDED TRANSFER SLAB	82
FIGURE 3.3.5.3b(i)	UNSHIELDED TRANSFER WALLS	83
FIGURE 3.3.5.3b(ii)	UNSHIELDED TRANSFER COLUMNS	83
FIGURE 3.5.4(a)	PLAN OF HS	86
FIGURE 3.5.4(b)	SECTIONAL DETAILS OF HS SLABS/WALLS	87
FIGURE 3.5.4(c)	SECTIONAL DETAILS OF HS SLABS/WALLS	88
FIGURE 3.5.4(d)	PLAN OF TWO HS WITH INTERNAL COMMON WALL	89
FIGURE 3.5.4(e)	SECTIONAL DETAILS OF TWO HS WITH AN INTERNAL COMMON WALL	90
FIGURE 3.5.4(f)	DETAILS OF HS WALL REINFORCEMENT BAR NEAR HS DOOR	91
FIGURE 3.5.4(g)	TYPICAL DETAILS OF EMBEDDED CONDUIT IN HS WALL	92
FIGURE 3.5.4(h)	TYPICAL DETAILS OF TRIMMER BARS FOR VENTILATION SLEEVE	93
FIGURE 3.5.4(i)	TYPICAL DETAILS OF TRIMMER BARS FOR WALL RECESS	93
FIGURE 3.5.4(j)	DETAILS OF SHEAR LINKS IN HS SLABS/WALLS	94
FIGURE 3.5.5(a)	PLAN OF HS WITH PRE-CAST HS DOOR FRAME PANEL (TYPE 1)	95
FIGURE 3.5.5(b)	DETAILS AND SECTIONS OF PRE-CAST HS DOOR FRAME PANEL WITH VENTILATION SLEEVE ABOVE IT (TYPE 1)	96
FIGURE 3.5.5(c)	SECTIONS OF PRE-CAST HS DOOR FRAME PANEL WITH VENTILATION SLEEVE ABOVE IT (TYPE 1)	97
FIGURE 3.5.5(d)	DETAILS AND SECTIONS OF PRE-CAST HS DOOR FRAME PANEL WITH VENTILATION SLEEVE AT ITS SIDE (TYPE 1)	98
FIGURE 3.5.5(e)	SECTIONS OF PRE-CAST HS DOOR FRAME PANEL WITH VENTILATION SLEEVE AT ITS SIDE (TYPE 1) ..	99
FIGURE 3.5.5(f)	PLAN OF HS WITH PRE-CAST HS DOOR FRAME PANEL (TYPE 2)	100

FIGURE 3.5.5(g)	DETAILS AND SECTIONS OF PRE-CAST HS DOOR FRAME PANEL WITH VENTILATION SLEEVE ABOVE IT (TYPE 2)	101
FIGURE 3.5.5(h)	SECTIONS OF PRE-CAST HS DOOR FRAME PANEL WITH VENTILATION SLEEVE ABOVE IT (TYPE 2)	102
FIGURE 3.5.5(i)	DETAILS AND SECTIONS OF PRE-CAST HS DOOR FRAME PANEL WITH VENTILATION SLEEVE AT ITS SIDE (TYPE 2)	103
FIGURE 3.5.5(j)	SECTIONS OF PRE-CAST HS DOOR FRAME PANEL WITH VENTILATION SLEEVE AT ITS SIDE (TYPE 2) ..	104
FIGURE 3.5.5(k)	PLAN OF HS WITH PRE-CAST HS DOOR FRAME PANEL (TYPE 3)	105
FIGURE 3.5.5(l)	DETAILS OF PRE-CAST HS DOOR FRAME PANEL (TYPE 3)	106
FIGURE 3.5.5(m)	SECTIONS OF PRE-CAST HS DOOR FRAME PANEL (TYPE 3)	107
FIGURE 3.5.5(n)	SECTIONS OF PRE-CAST HS DOOR FRAME PANEL (TYPE 3)	108
FIGURE 3.5.6.1(a)	PRECAST HS WITH HS DOOR ON LONGER WALL AND ONE OF VENTILATION SLEEVE ABOVE THE DOOR (TYPE 1)	111
FIGURE 3.5.6.1(b)	PRECAST HS WITH HS DOOR ON SHORTER WALL AND ONE OF VENTILATION SLEEVE ABOVE THE DOOR (TYPE 2)	111
FIGURE 3.5.6.1(c)	PRECAST HS SHOWING VENTILATION SLEEVE AND INTERNAL ELECTRICAL FIXTURES ON THE SAME WALL (TYPE 3)	112
FIGURE 3.5.6.1(d)	PRECAST HS AND C-SHAPED PRECAST HS CONNECTED AT THE SHORTER WALL AND WITH HS DOORS ON LONGER WALLS (TYPE 4)	112
FIGURE 3.5.6.1(e)	PRECAST HS AND C-SHAPED PRECAST HS CONNECTED AT THE LONGER WALL AND WITH HS DOOR ON LONGER WALLS (TYPE 5)	113
FIGURE 3.5.6.1(f)	PRECAST HS AND C-SHAPED PRECAST HS CONNECTED AT THE LONGER WALL AND WITH HS DOOR EACH ON LONGER WALL AND SHORTER WALL (TYPE 5A)	113
FIGURE 3.5.6.1(g)	PRECAST HS AND C-SHAPED PRECAST HS WITH CONNECTION BETWEEN LONGER AND SHORTER WALLS RESPECTIVELY AND WITH HS DOORS ON LONGER WALL (TYPE 6)	114

FIGURE 3.5.6.1(h)	PRECAST HS AND C-SHAPED PRECAST HS WITH CONNECTION BETWEEN LONGER AND SHORTER WALLS RESPECTIVELY AND WITH HS DOOR EACH ON LONGER WALL AND SHORTER WALL (TYPE 6A)	114
FIGURE 3.5.6.2(a)	REINFORCEMENT BAR DETAILS OF WALL, RIB AND BLAST DOOR ON LONG WALL OF PRECAST HS	115
FIGURE 3.5.6.2(b)	REINFORCEMENT BAR DETAILS OF WALL, RIB AND BLAST DOOR ON SHORT WALL OF PRECAST HS	115
FIGURE 3.5.6.2(c)	PLAN AND SECTION OF RIB WITH SHEAR LINKS	116
FIGURE 3.5.6.2(d)	REINFORCEMENT BAR DETAILS OF WALL AND RIB FOR C-SHAPED PRECAST HS	117
FIGURE 3.5.6.2(e)	REINFORCEMENT BAR DETAILS OF WALL AND RIB FOR C-SHAPED PRECAST HS	118
FIGURE 3.5.6.2(f)	CONNECTION DETAILS BETWEEN TWO PRECAST HS	119
FIGURE 3.5.6.2(g)	CONNECTION DETAILS BETWEEN PRECAST HS AND CAST IN-SITU WALL/COLUMN	120
FIGURE 3.5.6.2(h)	REINFORCEMENT BAR DETAILS AT CONCRETE RIB	121
FIGURE 3.5.6.2(i)	DETAILS OF REINFORCEMENT BARS NEAR DOOR FRAME AND AT ELECTRICAL FIXTURES ON INTERNAL FACE OF PRECAST HS	122
FIGURE 3.5.6.2(j)	DETAILS OF TRIMMER BARS FOR VENTILATION SLEEVE	123
FIGURE 3.5.6.2(k)	DETAILS OF TRIMMER BARS FOR WALL RECESS FOR HS DOOR HANDLE	123
FIGURE 3.5.6.2(l)	PRECAST HS WALL WITH CONNECTION DETAILS FOR VENTILATION SLEEVE AND ELECTRICAL SERVICES	124
FIGURE 3.5.6.2(m)	PRECAST HS WALL WITH CONNECTION DETAILS FOR ELECTRICAL SERVICES.....	125
FIGURE 3.5.6.2(n)	CAGE REINFORCEMENT BARS IN HOLLOW CORES	126
FIGURE 3.5.6.2(o)	REINFORCEMENT BARS LAPPING IN HOLLOW CORES	127
FIGURE 3.5.6.2(p)	HOLLOW CORE SHAPE	128
FIGURE 3.5.6.3(a)	ISOMETRIC VIEW OF PRECAST HS WITH BOLTS AND STEEL PLATE CONNECTION (TYPE 1 WITHOUT BLOCKED-OUT FOR BEAM)	129
FIGURE 3.5.6.3(b)	ISOMETRIC VIEW OF PRECAST HS WITH BOLTS AND STEEL PLATE CONNECTION (TYPE 2 WITHOUT BLOCKED-OUT FOR BEAM)	130

FIGURE 3.5.6.3(c)	SPLICE SLEEVE CONNECTION DETAILS BETWEEN PRECAST HS AND CAST IN-SITU ELEMENT AND BOLT CONNECTION DETAILS BETWEEN TWO PRECAST HS	131
FIGURE 3.5.6.3(d)	SPLICE SLEEVE CONNECTION DETAILS FOR PRECAST HS TOWER	131
FIGURE 3.5.6.3(e)	CONNECTION DETAILS BETWEEN LOWER AND UPPER PRECAST HS (DETAIL ‘A’)	132
FIGURE 3.5.6.3(f)	CONNECTION DETAILS BETWEEN LOWER AND UPPER PRECAST HS (DETAIL ‘B’)	133
FIGURE 3.5.6.3(g)	CONNECTION DETAILS BETWEEN LOWER AND UPPER PRECAST HS (DETAIL ‘C’)	134
FIGURE 3.5.6.3(h)	ISOMETRIC VIEW OF PRECAST HS WITH SPLICE SLEEVE CONNECTION (REINFORCEMENT BAR DETAILS)	135
FIGURE 3.5.6.3(i)	DETAIL OF SPLICE SLEEVE CONNECTION	136
FIGURE 3.5.6.3(j)	DETAILS OF PRECAST PLANK (MARKED AS PS) AND CONCRETE TOPPING	137
FIGURE 3.5.6.3(k)	ELECTRICAL FIXTURES ON EXTERNAL FACE OF PRECAST HS	138
FIGURE 3.5.6.3(l)	ISOMETRIC VIEW OF PRECAST HS WITH BOLTS AND STEEL PLATES CONNECTION (TYPE 3 WITH BLOCKED-OUT FOR BEAM)	139
FIGURE 3.5.6.3(m)	ISOMETRIC VIEW OF PRECAST HS WITH BOLTS AND STEEL PLATES CONNECTION (TYPE 4 WITH BLOCKED-OUT FOR BEAM)	139
FIGURE 3.6.1(b)	MOUNTING OF SERVICES ON EXTERNAL WALL OF A HS	140
FIGURE 3.6.1(d)	TYPICAL DETAILS OF EMBEDDED SOCKET/SWITCH	141
FIGURE 3.6.2	ENCASEMENT DETAILS OF WATER/GAS SERVICE PIPES PENETRATING THROUGH HS WALL	142
FIGURE 3.6.3(a)	REINFORCEMENT DETAIL OF REFUSE CHUTE ABOVE ROOF LEVEL	143
FIGURE 3.6.3(b)	REINFORCEMENT DETAIL ‘A’ OF RISER ADJACENT TO HS AND ABOVE ROOF LEVEL	144
FIGURE 3.6.3(c)	REINFORCEMENT DETAIL ‘B’ OF RISER ADJACENT TO HS WITH PROJECTION ABOVE ROOF LEVEL	145

LIST OF FIGURES (CHAPTER 4)

FIGURE 4.2(a)	POSITION OF VENTILATION SLEEVES	148
FIGURE 4.2(b)	SECTIONAL VIEWS OF VENTILATION SLEEVES	149
FIGURE 4.3.1	MINIMUM CLEARANCE FOR FRAGMENTATION PLATE	150
FIGURE 4.3.2	PERFORATED ACCESS PANEL BELOW VENTILATION SLEEVE	150
FIGURE 4.4(a)	DETAILS OF VENTILATION SLEEVE AND FRAGMENTATION PLATE	151
FIGURE 4.4(b)	VIEWS AND SECTION OF VENTILATION SLEEVE	152

LIST OF FIGURES (CHAPTER 5)

FIGURE 5.3(a)	LOCATION OF NOTICE ON HS DOOR	154
FIGURE 5.3(b)	SAMPLE HS DOOR NOTICE	155

CHAPTER 1: INTRODUCTION

1.1 GENERAL

A household shelter (HS) is designed and constructed for the protection of people against weapon effects during a National emergency. It should not be used for protection during other emergency situations such as a fire in a building. For the convenience of the occupants, HS is located inside the individual house or flat.

HS shall be incorporated as part of the house or flat. This can be achieved by efficient space planning as well as optimal integration of the HS location with other spaces in a house or flat.

1.2 APPLICATION OF HS TECHNICAL REQUIREMENTS

The Technical Requirements for HS are applicable to all houses or flats, which are intended as complete and separate units for purpose of private dwelling.

1.3 PEACETIME USE

Every HS shall be designed to a specific peacetime use. The other statutory requirements governing the design and use of the HS space shall also be complied with.

1.4 ABBREVIATIONS

<u>Clause</u>	<u>Description</u>	<u>Abbreviation</u>
1.1	Household Shelter	HS
2.1	Non-Shelter	NS
2.4.1 (b)	External Building Line	EBL
2.5.2 (e)	Finished Floor Level	FFL
2.6	Precast Hollow Core Household Shelter	Precast HS
Table 2.2.1 (b)	Gross Floor Area	GFA

1.5 **DEFINITIONS**

<u>Clause</u>	<u>Definition</u>	<u>Term</u>
2.1	The space in the HS tower that is not intended for use as a shelter.	Non-Shelter
2.2.1 (d)	Relevant Authority means the Commissioner of Singapore Civil Defence Force and includes officers authorised by him generally or specifically to exercise the powers, functions and duties conferred by the Civil Defence Shelter Act.	Relevant Authority
2.2.2 (a)	Height of HS measured from its FFL to the soffit of the HS ceiling slab.	HS Clear Height
2.2.2 (b)	Height of NS measured from its FFL to the soffit of the NS ceiling slab.	NS Clear Height
2.3.2 (a)	The HS located below main roof level.	Top-most HS
2.4.1 (a)	Distance from external face of a HS wall to the nearest EBL.	Setback Distance
2.4.1 (b)	The edge line of the ceiling slab above the HS wall under consideration.	External Building Line (EBL)
2.4.1 (d)	A storey which is below the first storey and has at least half of the height of the storey below the level of the ground adjoining its perimeter walls.	Basement
2.4.2	Where HS (or NS, where applicable) on every storey is located one on top of the other to form a vertical tower.	HS Tower
2.4.6	HS located in the basement of a landed house.	Basement HS

CHAPTER 2: ARCHITECTURAL REQUIREMENTS

2.1 HS OR NS FORM

The configuration of a HS or NS on plan shall be rectangular, square, trapezoidal or L-shaped.

2.2 SIZE OF HS

2.2.1 Area and Volume

- (a) The maximum internal length of any floor and roof slab of a HS shall be 4000 mm. The minimum internal width of a HS shall be 1200 mm. The internal length and width of HS walls shall be designed with an increment of 50mm. See FIGURE 2.2.1(a).
- (b) If the configuration of HS on plan is rectangular or square, the minimum internal floor area and minimum internal volume of a HS shall be in accordance with TABLE 2.2.1(b).
- (c) If the configuration of HS on plan is trapezoidal or L-shaped, the minimum internal floor area, minimum internal volume of a HS and the number of 0.6 m x 0.6 m square units shall be as specified in TABLE 2.2.1(c) and as illustrated in FIGURE 2.2.1(a).
- (d) The maximum internal floor area of a HS shall be 4.8 m². Internal floor area exceeding 4.8m² may be allowed subject to the approval from the relevant authority.

2.2.2 Heights

- (a) The minimum and maximum HS clear height shall be 2400 mm and 3900 mm respectively. See FIGURE 2.2.2(a).
- (b) The maximum NS clear height shall be 3900 mm. Where NS clear height is more than 3900 mm, intermediate RC slab or RC beams shall be provided. The RC beams shall be designed with at least equivalent stiffness to RC slab. If the NS is designed with 2 walls, RC beams shall be provided at the peripheral of NS. See FIGURE 2.2.2(b).

2.3 WALL AND SLAB THICKNESS OF HS AND NS

2.3.1 Wall Thickness of HS and NS

- (a) The minimum HS and NS wall thickness shall be in accordance with TABLE 2.3.1(a) for landed development and TABLE 2.3.1(b) for non-landed development.

- (b) Wall thickness of any HS or NS within the HS tower shall not be less than the wall thickness of the HS or NS above it.
- (c) The minimum thickness of the internal common wall between two adjacent HS for non-landed and landed cluster housing developments shall be 200 mm thick. See FIGURE 2.3.1(c).
- (d) For landed developments where the two HS are abutting each other, the common wall shall be cast as two separate adjoining walls. See FIGURE 2.3.1(d).
- (e) The minimum thickness of the basement HS wall facing a reinforced concrete basement storey wall without any opening within the influence zone shall be 200 mm. See FIGURE 2.4.6(a) and FIGURE 2.4.6(b).
- (f) The minimum thickness of the basement HS wall which is in direct contact with earth throughout its entire height shall be in accordance with FIGURE 2.4.6(c).
- (g) The minimum thickness of the basement HS wall facing a reinforced concrete basement storey wall with opening within the influence zone shall be in accordance with TABLE 2.3.1(a).

2.3.2 Slab Thickness of HS and Enclosed NS

- (a) Ceiling slab of top-most HS in non-landed development - 300 mm. See FIGURE 2.3.2.
- (b) Slab between 2 HS - 175 mm. See FIGURE 2.3.2.
- (c) Floor slab of bottom-most HS or NS in contact with soil – 200 mm. See FIGURE 2.3.2.
- (d) Slab between 2 enclosed NS – 175 mm. See FIGURE 2.3.2.
- (e) Slab between HS and enclosed NS – 175 mm. See FIGURE 2.3.2.
- (f) Ceiling slab of top-most HS in landed development – 300 mm or 250 mm (if there is a RC roof or another RC slab above the HS that is equal or extend beyond the required setback distance of that HS wall). See FIGURE 2.3.2(f).

2.3.3 Slab Thickness of HS and Non-Enclosed NS

- (a) Floor slab of HS that is directly supported by non-enclosed NS, NS walls or columns – 300 mm. See FIGURE 2.3.2.
- (b) Ceiling slab of HS which is below non-enclosed NS, NS walls or columns – 300mm. See FIGURE 2.3.2.
- (c) Slab between 2 non-enclosed NS – 175 mm. See FIGURE 2.3.2.

2.4 **LOCATION OF HS**

2.4.1 **HS Position**

- (a) A HS has to be positioned such that the setback distance of each HS wall shall be as large as practical, and shall not be less than the minimum specified setback distance.
- (b) A HS with minimum 300mm thick ceiling slab in a landed house may have one of its walls (without HS door) abutting or near to an air well. The air well, has to be located such that it abuts a party wall and/or is surrounded by habitable space at ceiling slab level of the HS. The air well edge line shall not be regarded as EBL for the purpose of determining the minimum setback distance. The area of the air-well shall not be larger than 4.2m² and the longer side of the air-well shall not be larger than 2.8m. FIGURE 2.4.1(b).
- (c) Where a staircase in a landed house is located within setback distance of the HS wall (without HS door), such staircase can be built of either reinforced concrete or metal/steel or timber materials provided that it is covered with either reinforced concrete roof or clay tile roof. See FIGURE 2.4.1c(i) & FIGURE 2.4.1c(ii).
- (d) A HS can also be located in the basement of a landed house. Where the HS is located underground away from basement of landed house, an underground access route leading to HS must be provided with a reinforced concrete ceiling slab of minimum thickness of 125 mm.

2.4.2 **HS Tower**

- (a) In a building of more than one-storey, the HS (or NS, if any) on every storey shall be located one on top of the other to form a vertical tower with its walls (where applicable) continuing to the foundation. See FIGURE 2.4.2(a).
- (b) Larger HS below the main roof level is allowed in the HS tower provided that:
 - i) The number of the larger HS shall not be more than one third of the total number of storeys of a building or capped at 5 larger HS, whichever is lesser; and
 - ii) Only one wall of the larger HS is allowed to be relocated and discontinuous from the wall of the lower HS below it. See FIGURE 2.4.2(b).
- (c) The space within a NS is not intended for protection of occupants during a National Emergency.

2.4.3 **Setback Distances of HS Walls (Without Reinforced Concrete Down-hang Beams along EBL)**

- (a) The HS walls shall be located at minimum setback distances from the EBL (See FIGURE 2.4.3a (i) and FIGURE 2.4.3a (ii)). The setback distances of the HS wall with HS door and the remaining 3 HS walls shall comply with TABLE 2.4.3(a).

- (b) Where the storey height of a HS on the first storey is up to 3.6 m and is greater than the storey heights of the HS directly above it, the minimum setback distances of the HS on the first storey shall be at least the same as the setback distances of the HS above it.
- (c) Trellis constructed of RC or steel hollow section may be used to make up for the shortfall in setback distance for HS walls (without HS door). However, a minimum 1000 mm RC ceiling slab measured from the HS wall shall be provided. A perpendicular or parallel trellis arrangement, or a combination of both, with respect to the HS wall concerned, shall comply with the geometrical configuration as shown in FIGURE 2.4.3(c).

2.4.4 Setback Distances of HS Walls (With Reinforced Concrete Down-hang Beams along EBL)

- (a) Where a down-hang beam is provided along the EBL in front of HS walls, the minimum setback distance of that HS wall can be reduced based on the effective storey height and in accordance with TABLE 2.4.4(a). The effective storey height is determined by the storey height less the depth ‘d’ of the down-hang beam (See FIGURE 2.4.4 (a)). If a down-hang beam is also provided along the EBL in front of the HS wall with HS door, the setback distance of this wall shall be in accordance with TABLE 2.4.4(a).
- (b) Trellis constructed of RC or steel hollow section may be used to make up for the shortfall in setback distance for HS walls (without HS door). However, a minimum 1000 mm RC ceiling slab measured from the HS wall shall be provided (FIGURE 2.4.4(b)). A perpendicular or parallel trellis arrangement, or a combination of both, with respect to the HS wall concerned, shall comply with the geometrical configuration as shown in FIGURE 2.4.3(c).
- (c) Where the storey height of a HS on the first storey is up to 3.6 m and is greater than the storey heights of the HS directly above it, the minimum setback distances of the HS on the first storey shall be at least the same as the setback distances of the HS above it. Where a down-hang beam is provided at 2nd storey ceiling slab, the same down-hang beam shall be provided at 1st storey ceiling slab.
- (d) Clause 2.4.4 shall apply only if the width of the reinforced concrete down-hang beam is at least 125 mm.

2.4.5 Full Height Shielding Walls to HS Wall (without HS Door)

- (a) Where HS is located close to exterior face of buildings or along external building line and there is a shortfall in the setback distance, it can be shielded by full height shielding walls with air gap in place of the required shielding floor slab within the setback distance envelop. The full height shielding walls for such HS at different locations are shown in Figure 2.4.5 (a) to 2.4.5 (g) and as specified:
 - (i) Shielding wall “A” and “B” for HS with shortfall of setback distance on one side of HS (Type 1A, 1B & 1C). See Figure 2.4.5 (a), Figure 2.4.5 (b) and Figure 2.4.5 (c).

- (ii) Shielding wall “A” and “B” for HS with shortfall of setback distance on two sides of HS (Type 2A & 2B). See Figure 2.4.5 (d) & Figure 2.4.5 (e).
 - (iii) Shielding wall “C” and “D” for HS with shortfall of setback distance at one corner of HS. (Type 3A). See Figure 2.4.5 (f).
 - (iv) Shielding wall “C” and “E” for HS with shortfall of setback distance at one corner of HS. Type 3B). See Figure 2.4.5 (g).
- (b) The materials and dimensions of the shielding walls “A” to “E” shall comply with the following:
- (i) Shielding wall “A” covering the entire length of the HS wall, shall have an extension of minimum 300mm as shown in the Figure 2.4.5 (a), Figure 2.4.5 (b) and Figure 2.4.5 (c). The thickness and air gap for this shielding wall shall be:
 - minimum 150mm thick precast reinforced concrete wall with an air gap of 175mm, or
 - minimum 200mm thick brick or solid block wall with an air gap of 175mm, or
 - minimum 225mm thick brick or solid block wall with an air gap of 150mm.
 - (ii) Shielding wall “B”, “C”, and “D” shall be minimum 100mm thick precast reinforced concrete wall or 200mm thick brick or solid block wall. This shielding wall shall be continuous and covers the entire setback distance along shielding wall.
 - (iii) Shielding Wall “E” can be built of RC or steel trellis. The minimum member size of RC trellis is 125mm by 125mm. The steel hollow section of steel trellis shall be minimum size of 125mm by 125 by 6mm thick. This shielding wall shall be continuous and cover the entire setback distance along the HS wall.

2.4.6 Setback Distances of Basement HS

- (a) For the HS in the basement, the minimum setback distances of the HS wall with HS door and the remaining 3 HS walls shall comply with the TABLE 2.4.6(a). (See FIGURE 2.4.6(a)).
- (b) There is no setback distance requirement for basement HS wall with door if it faces a reinforced concrete basement wall not in direct contact with earth and the distance between them is at least 1500 mm (with no openings within the influence zone). (See FIGURE 2.4.6(b))
- (c) There is no setback distance requirement for basement HS wall (without HS door) of landed house (See FIGURE 2.4.6(c)) if the HS wall is:

- (i) 200mm thick and earth backing of up to HS roof level is of minimum distance 1000mm measured from the external face of the HS wall; or
- (ii) 250mm thick and earth backing of up to HS roof level is of minimum distance 300mm measured from HS wall. The scupper drain (if any) is allowed to be located minimum 300mm away from the HS wall; or
- (iii) 200mm thick and facing a reinforced concrete basement wall which is in direct contact with earth backing up to a minimum distance of 300mm throughout its full height.
- (iv) 200mm thick and facing a reinforced concrete basement storey wall not in direct contact with earth and the distance between them is at least 800 mm (with no openings within the influence zone).

2.4.7 RC Lift Core or/and Refuse Chute or/and Service Riser located within Setback Distance of HS

- (a) RC lift core can be located within the setback distances of HS walls. Where the RC lift core is abutting the HS wall, they shall comply with the requirements shown in FIGURE 2.4.7a.
- (b) Where the refuse chute is abutting the HS or located within the setback distances and it protrudes above the main roof, they shall comply with the requirements shown in FIGURE 2.4.7b(i) to 2.4.7b(ii).
- (c) Where the service riser is abutting the HS or located within the setback distances and it protrudes above the main roof, they shall comply with the requirements shown in FIGURE 2.4.7c(i) to 2.4.7c(v).

2.5 HS DOOR

2.5.1 Dimensions

- (a) The opening dimensions of HS door shall be 700mm (W) x 1900mm (H) See FIGURE 2.5.1(a).
- (b) HS door frame that is cast together with the HS wall shall have single or double door rebate. See FIGURE 2.5.1(a) and FIGURE 2.5.1(b).

2.5.2 Door Frame

- (a) There shall be a minimum 150mm reinforced concrete nib next to vertical edge of the HS door frame. (See FIGURE 2.5.2(a)).
- (b) For pre-cast door frame panel of Type 1, the reinforced concrete next to two vertical edges of the HS door frame shall be 300mm each. See FIGURE 3.5.5(a).

- (c) For pre-cast door frame panel of Type 2, the reinforced concrete next to vertical edges of the HS door frame shall be 300mm on one side, and 150mm plus the HS wall thickness on the other side. See FIGURE 3.5.5(f).
- (d) For pre-cast door frame panel of Type 3, the reinforced concrete panel with full length or width of HS wall must be properly connected to the in-situ HS walls and slabs. See FIGURE 3.5.5(l).
- (e) The door frame must be positioned such that its door is above FFL and can be opened at least 90°. (See FIGURE 2.5.2 (e)).

2.5.3 Strengthened Ceiling Slab Outside HS Door and HS Walls

The minimum thickness of the reinforced concrete ceiling slab immediately outside the HS wall with HS door shall be 125 mm and structurally connected to HS tower (See FIGURE 2.5.3). This requirement shall only apply to HS in non-landed houses.

2.6 PRECAST HOLLOW CORE HOUSEHOLD SHELTERS (PRECASTHS)

2.6.1 Design of Precast Hollow Core Household Shelters (Precast HS)

Precast hollow core household shelter shall be designed as a complete HS and constructed for residential developments with GFA of 2000m² and above. For two adjoining HS, they can be formed by a complete HS and a C-shaped HS. The various designs of precast hollow core HS are as follows:

- (a) Precast HS with HS door on longer wall and one of the ventilation sleeves above the door. See FIGURE 2.6.1(a).
- (b) Precast HS and C-shaped Precast HS connected at the shorter wall and with HS door on longer walls. See FIGURE 2.6.1(b).
- (c) Precast HS and C-shaped Precast HS connected at the longer wall and with HS door on longer walls. See FIGURE 2.6.1(c).
- (d) Precast HS and C-shaped Precast HS with connection between longer and shorter walls respectively and with HS doors on long wall. See FIGURE 2.6.1(d).
- (e) Precast HS adjoining cast in-situ walls/ columns. See FIGURE 2.6.1(e).

2.6.2 Dimensions

- (a) The internal length (L) and width (W) of the HS Walls shall be modular in size with an increment of 50mm.
- (b) Precast HS showing the arrangement of hollow cores in HS wall with its dimension (See FIGURE 3.5.6.1(a) to FIGURE 3.5.6.1(h)) and spacing, wall thickness, blast door, ventilation sleeves and electrical services shall be designed with dimensions as shown in Tables 3.5.6(a), 3.5.6(b) and 3.5.6(c).

- (c) Hollow cores shall be modular in size with an increment of 100mm for its length and 25mm for its width. See FIGURE 2.6.2(c).
- (d) The spacing between two adjacent hollow cores in HS wall shall be 100mm.
- (e) There shall be a minimum 150mm reinforced concrete nib next to vertical edge of the HS door frame.
- (f) Shear key of 35mm high shall be provided on wall above the HS door. See FIGURE 2.6.2(f).

2.7 **FIXTURES IN HS**

2.7.1 **General**

- (a) The following electrical and communication fixtures in steel or PVC conduit system shall be provided inside the HS to provide basic stay-in and communication facilities:
 - i) 13A switched socket outlets;
 - ii) Switch and lighting points;
 - iii) TV outlets;
 - iv) Communication line for telephony outlet;
- (b) The electrical and communication fixtures shall be designed and installed in accordance with the relevant local Codes of Practice for Info-communication Facilities in Building (COPIF) and statutory requirements for peacetime usage.
- (c) The mounting height of the lighting switch shall not exceed 1200 mm from the FFL. The other electrical and communication fixtures shall be mounted at between 450 mm and 1200mm from the FFL to comply with the requirement as stipulated in the building codes. See FIGURE 2.7.1(c).
- (d) Other fixtures, such as cabinets and shelves, which are required for peacetime use, are allowed provided they are easily dismantled and removed.

2.7.2 **Power Points**

One 13A switched socket outlet shall be provided in the vicinity of adjacent to the TV outlets. An additional 13A switched socket outlet shall be provided for other electrical appliances such as fan.

2.7.3 **Light Fittings**

Light fittings shall be mounted on the soffit of HS ceiling slab using screws with non-metallic inserts. Wall-mounted light fittings are not permitted.

2.7.4 **Cable Entries and Openings**

All cable entry openings to the HS shall be fully and properly sealed to ensure air-tightness as required under Clause 3.6.

2.8 NS IN HS TOWER

2.8.1 Aggregate Wall Heights of NS

- (a) Several NS can be stacked one on top of the other within an HS tower, without the need for NS floor slab to be connected to external floor slab, provided that the aggregate wall height of the NS does not exceed 12m (See FIGURE 2.8.1(a)).
- (b) Aggregate wall height of NS refers to the sum of the height(s) of NS between two levels of the HS tower where the full external perimeters of the HS tower at those levels are structurally connected by floor slabs or tie beams to the structural frame of the building. The tie beams shall be designed with at least equivalent stiffness to the floor slab.
- (c) The minimum thickness of the intermediate slabs between 2 NS shall be 175 mm.

2.8.2 Shielded and Unshielded NS Walls/Columns

The relevant architectural technical requirements of the shielded and unshielded NS Columns/ Walls as stipulated in Chapter 3 Clause 3.3 shall be complied with.

2.9 TRANSFER STRUCTURE SUPPORTING HS TOWER

2.9.1 General

If the loads from walls of HS towers cannot be carried directly to the foundation, transfer structure can be used to carry the loads indirectly to the foundation. The transfer structure could take the form of slab, beams, or combination of both. When transfer structure is provided to carry HS tower, additional technical requirements described herein shall be complied with. Please note the following conditions in the HS tower design supported by transfer structure:

- (a) RC slab shall be used as the shielding element of the transfer structure and its supporting columns and walls. See FIGURE 2.9.1(a) and FIGURE 2.9.1(b).
- (b) The use of trellis or/and the adjacent building structure as shielding element of the transfer structure and its supporting columns and walls of HS is not allowed.
- (c) Only one transfer of HS loads in each tower by the transfer structure to its supporting columns and/ or walls is allowed. Multiple transfers of HS loads from the same HS tower are not allowed.
- (d) For unshielded exterior columns, the minimum size (either its diameter or the shorter dimension) shall be 500 mm.
- (e) The use of pre-stressed concrete for the transfer structure and its supporting columns and walls is not permitted.

2.9.2 Transfer Structure

Additional design checks on transfer structure supporting HS tower is required. See Chapter 3 - Clause 3.3.

2.10 HS BENEATH AN INTERNAL STAIRCASE

If a HS is located beneath an internal staircase, the following requirements shall apply. See Figure 2.10.

- (a) For the purpose of determining the minimum internal floor area of the HS in accordance with TABLE 2.2.1 (b) and TABLE 2.2.1 (c), only the portion of the space with clear height of at least 1500 mm shall be taken into account.
- (b) For the purpose of determining the minimum internal volume of the HS in accordance with TABLE 2.2.1 (b) and TABLE 2.2.1 (c), the entire enclosed space may be used.
- (c) The minimum thickness of the HS ceiling slab and waist of the staircase shall be 300 mm.
- (d) The minimum unobstructed distance from the HS wall with ventilation sleeve opening to the nearest face of any other internal structural element shall be at least 700 mm. This is to facilitate the installation of a gas filtration unit when required during a National Emergency.

2.11 FINISHES IN HS

Finishes within a HS shall comply with the following:

- (a) The walls and the ceiling slab shall be cast with a smooth concrete finish.
- (b) The walls and ceiling slab may be finished with a skim coat of not thicker than 2 mm.
- (c) No plastering or tiling shall be permitted on the walls and ceiling slab.
- (d) Floor tiles or floor finishes, which are laid on wet cement mortar, are permitted.
- (e) Skirting tiles laid on wet cement mortar are permitted up to a maximum 100 mm high above the FFL.

2.12 EXIT STAIRCASE

Where there is only one exit staircase or exit scissors-staircase serving the non-landed houses, the minimum waist of exit staircase and the thickness of the intermediate landing slab shall be 150 mm. The staircase shall be constructed of reinforced concrete.

2.13 DOOR RECESS ON HS WALL

A door recess on HS wall to accommodate the protrusion of the HS door handle when the HS door is fully open is allowed provided that (See FIGURE 2.13):

- (a) The dimensions are not larger than 160 mm (length) x 80 mm (height) x 40 mm (depth) for HS wall of minimum 250 mm thickness.
- (b) The spacing between the HS door handle recess and the external/ or internal socket points shall be at least 300 mm apart.

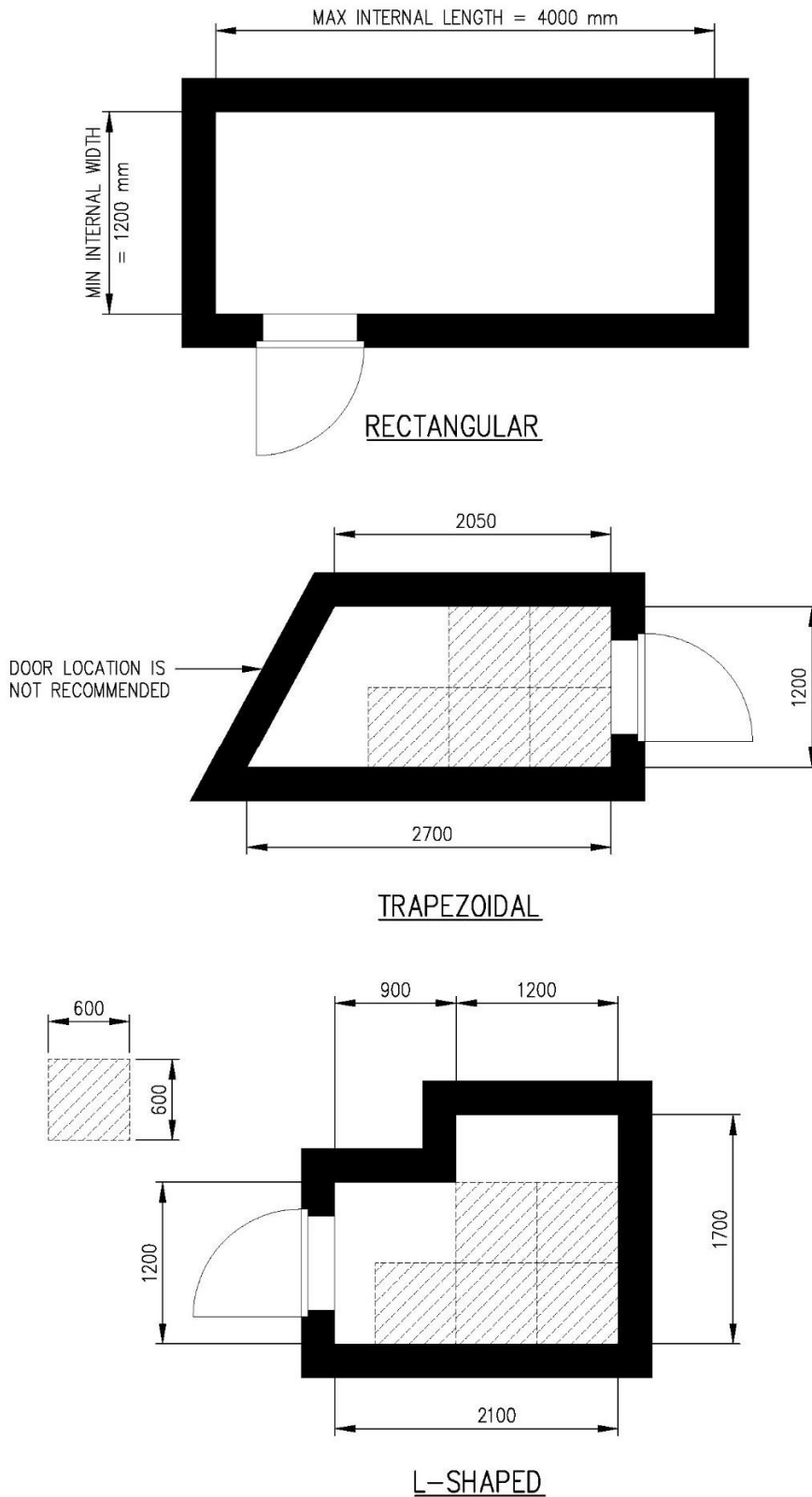

**FIGURE 2.2.1(a) EXAMPLES OF HS OF DIFFERENT SHAPES
(FOR GFA = 100m², HS SIZE = 2.8m², NUMBER OF SQUARE UNITS = 5)**

TABLE 2.2.1 (b): MINIMUM INTERNAL HS FLOOR AREA AND VOLUME

GFA* of a House (m ²)	HS Floor Area (m ²)	HS Volume (m ³)
GFA ≤ 40	1.44	3.6
40 < GFA ≤ 45	1.6	3.6
45 < GFA ≤ 75	2.2	5.4
75 < GFA ≤ 140	2.8	7.2
GFA > 140	3.4	9.0

* The GFA refers to GFA of the house which shall be in accordance with prevalent URA guidelines. Service balconies, which are commonly provided at the utility areas for the purpose of drying clothes, would therefore not qualify for exclusion.

TABLE 2.2.1 (c): NUMBER OF SQUARE UNITS (0.6m x 0.6m) USED FOR THE ASSESSMENT OF TRAPEZOIDAL OR L-SHAPRED HS

GFA* of a House (m ²)	HS Floor Area (m ²)	HS Volume (m ³)	Number of Square Units
GFA ≤ 40	1.44	3.6	3
40 < GFA ≤ 45	1.6	3.6	3
45 < GFA ≤ 75	2.2	5.4	4
75 < GFA ≤ 140	2.8	7.2	5
GFA > 140	3.4	9.0	6

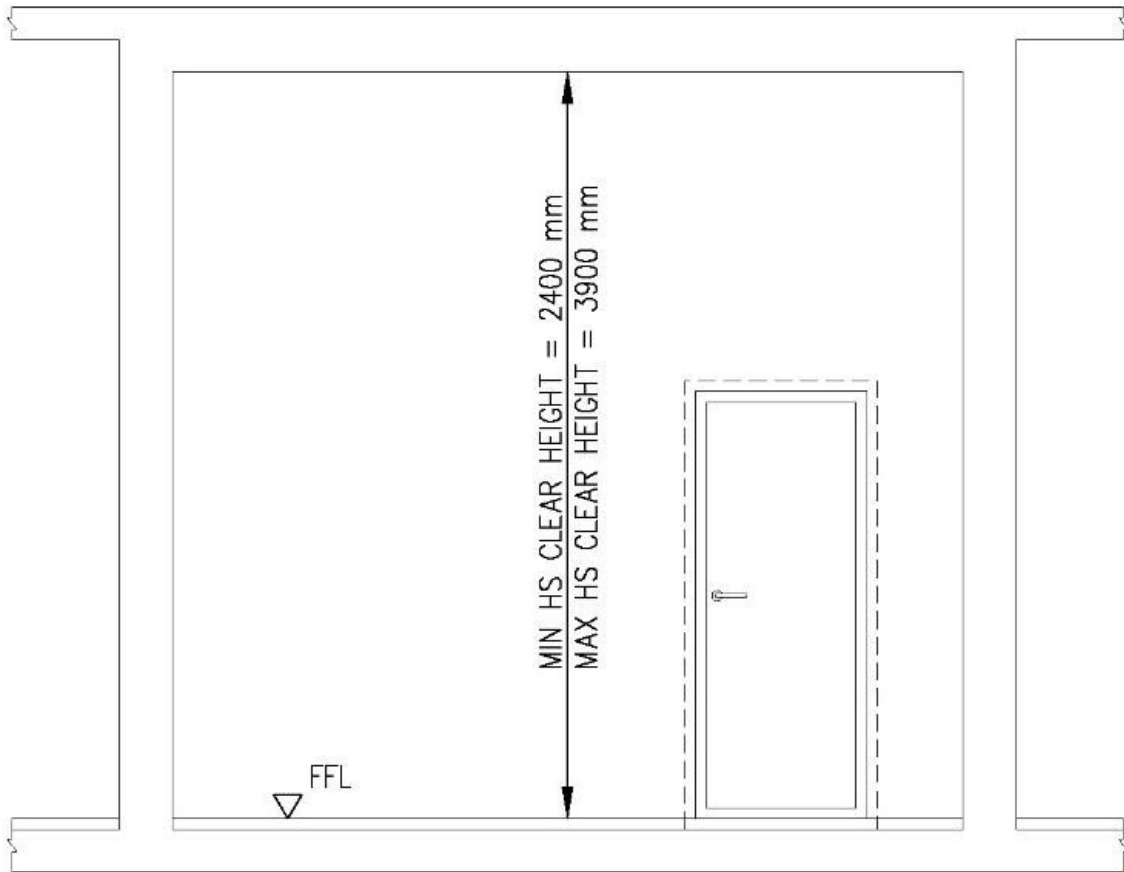

FIGURE 2.2.2(a) HS CLEAR HEIGHT IN NON-LANDED AND LANDED DEVELOPMENTS

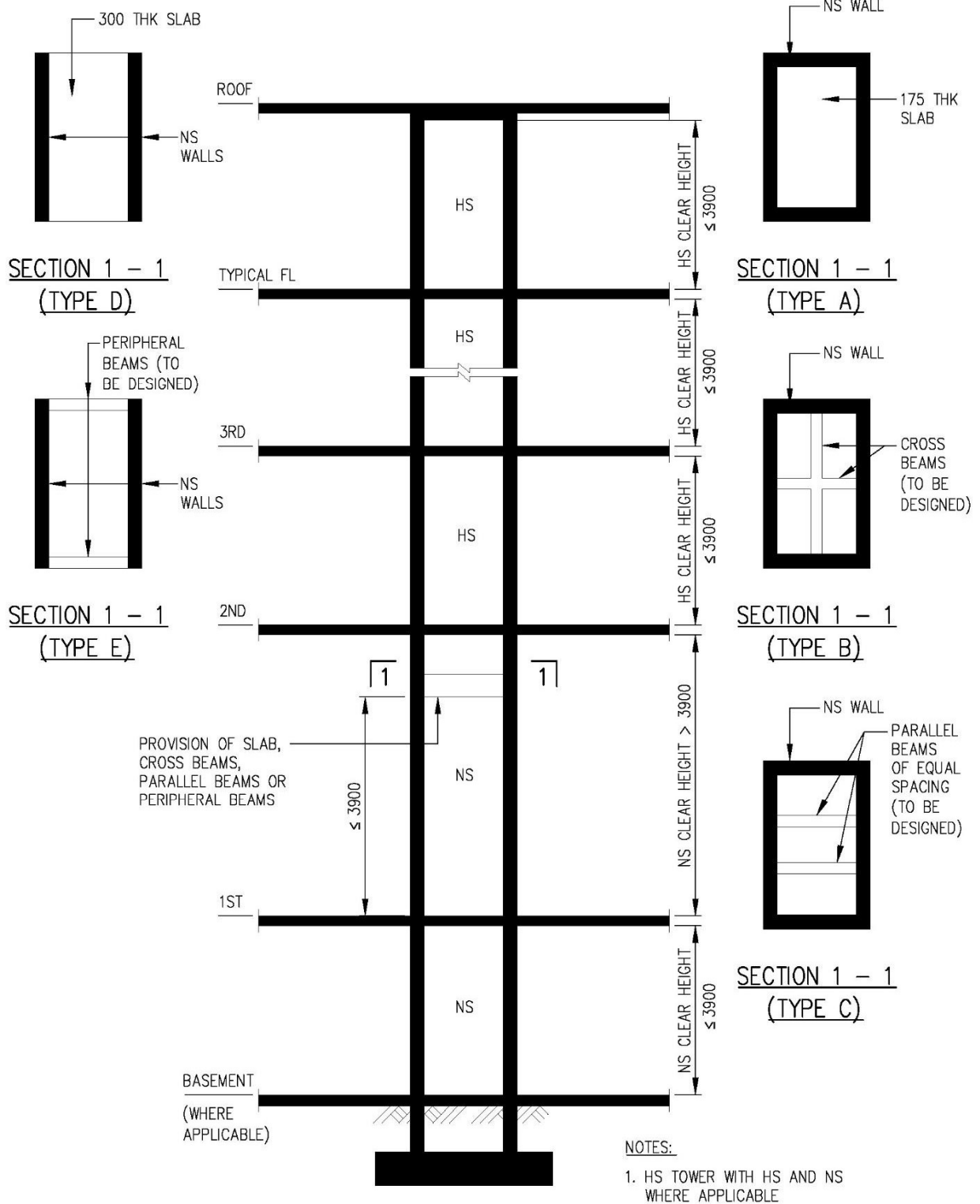

FIGURE 2.2.2(b) SECTION OF HS TOWER SHOWING HS AND NS CLEAR HEIGHTS

**TABLE 2.3.1(a): MINIMUM HS AND NS WALL THICKNESS
(FOR LANDED DEVELOPMENTS)**

Storey Height (mm)	HS Clear Height (mm)	Setback Distance of HS Wall (mm)	Wall Thickness (mm)
Ht ≤ 4000	2400 ≤ Ht ≤ 3900	≤ 6000mm	250
		> 6000mm	200
4000 < Ht ≤ 6000	2400 ≤ Ht ≤ 3900	≤ 7000mm	250
		> 7000mm	200
6000 < Ht ≤ 8000	2400 ≤ Ht ≤ 3900	≤ 8000mm	250
		> 8000mm	200
8000 < Ht ≤ 10000	2400 ≤ Ht ≤ 3900	≤ 9000mm	250
		> 9000mm	200

**TABLE 2.3.1(b): MINIMUM HS AND NS WALL THICKNESS
(FOR NON-LANDED DEVELOPMENTS)**

Storey Height (mm)	HS Clear Height (mm)	Setback Distance of HS Wall (mm)	Wall Thickness (mm)
Ht ≤ 4000	2400 ≤ Ht ≤ 3000	≤ 6000	250
		> 6000	200
	3000 < Ht ≤ 3200	≤ 6000	275
		> 6000	225
	3200 < Ht ≤ 3900	≤ 6000	300
		> 6000	250
4000 < Ht ≤ 6000	2400 ≤ Ht ≤ 3000	≤ 7000	250
		> 7000	200
	3000 < Ht ≤ 3200	≤ 7000	275
		> 7000	225
	3200 < Ht ≤ 3900	≤ 7000	300
		> 7000	250
6000 < Ht ≤ 8000	2400 ≤ Ht ≤ 3000	≤ 8000	250
		> 8000	200
	3000 < Ht ≤ 3200	≤ 8000	275
		> 8000	225
	3200 < Ht ≤ 3900	≤ 8000	300
		> 8000	250
8000 < Ht ≤ 10000	2400 ≤ Ht ≤ 3000	≤ 9000	250
		> 9000	200
	3000 < Ht ≤ 3200	≤ 9000	275
		> 9000	225
	3200 < Ht ≤ 3900	≤ 9000	300
		> 9000	250

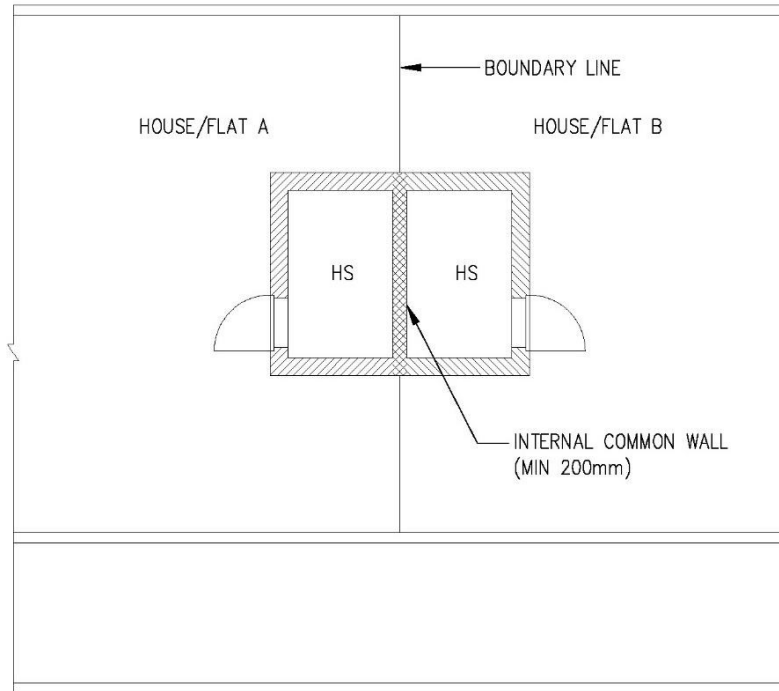

ALTERNATIVE 1

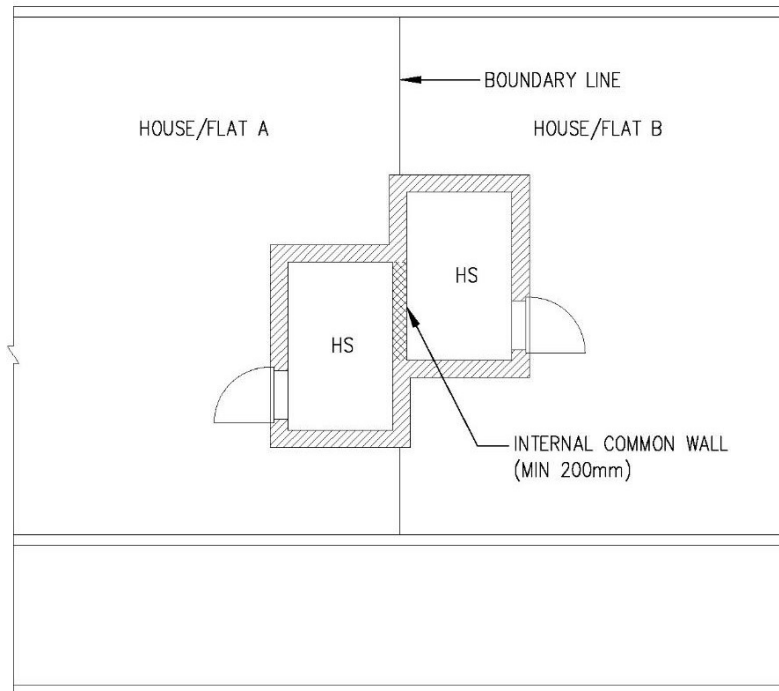

ALTERNATIVE 2

FIGURE 2.3.1(c) INTERNAL COMMON WALL BETWEEN TWO HS IN NON-LANDED AND LANDED CLUSTER HOUSING DEVELOPMENTS

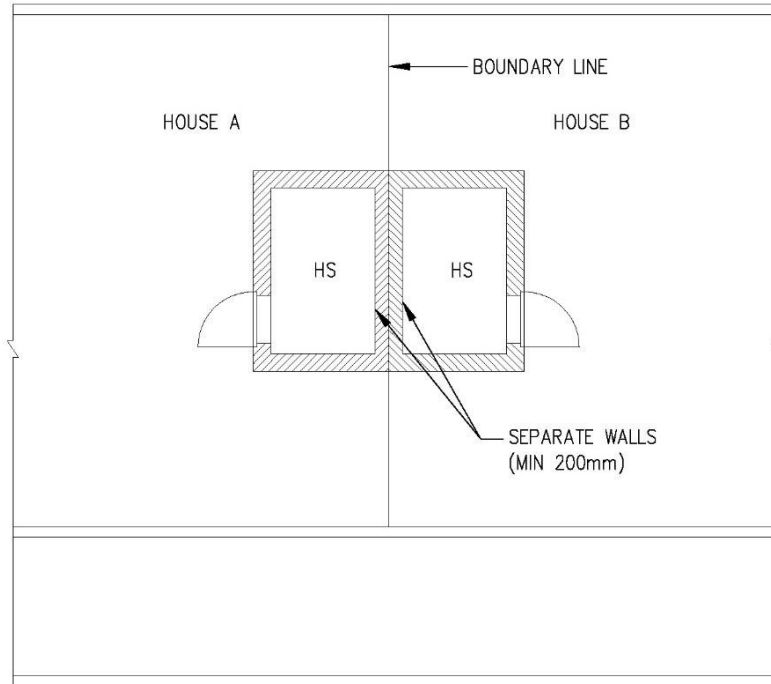

ALTERNATIVE 1

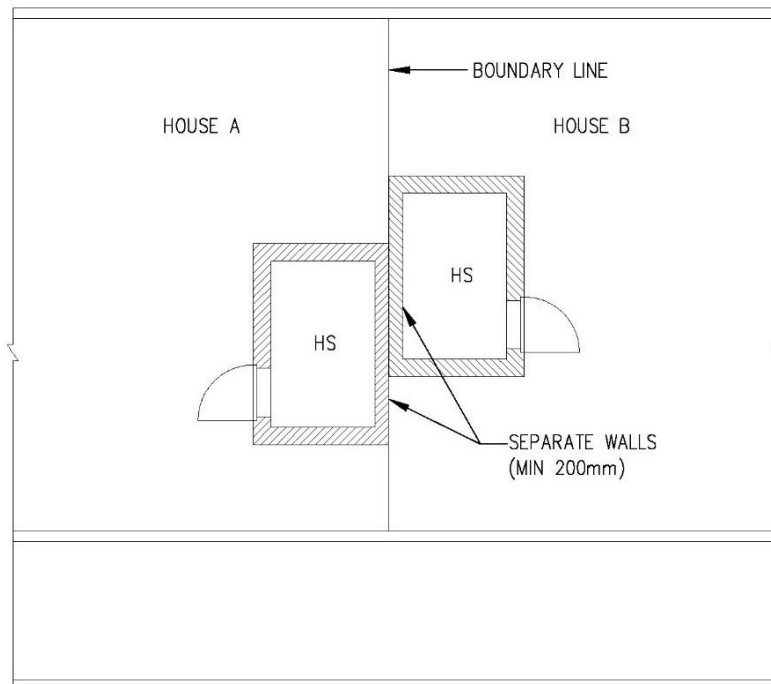

ALTERNATIVE 2

FIGURE 2.3.1(d) SEPARATE WALLS BETWEEN TWO HS IN INTERMEDIATE LANDED DEVELOPMENTS

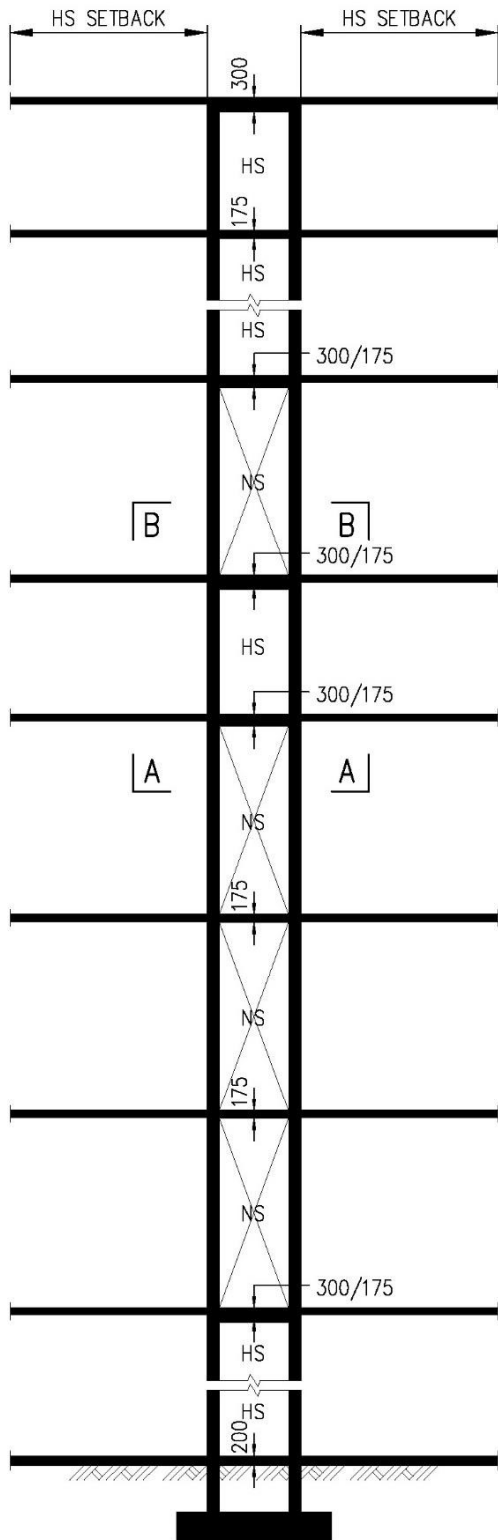

HS TOWER
(HS/NS)

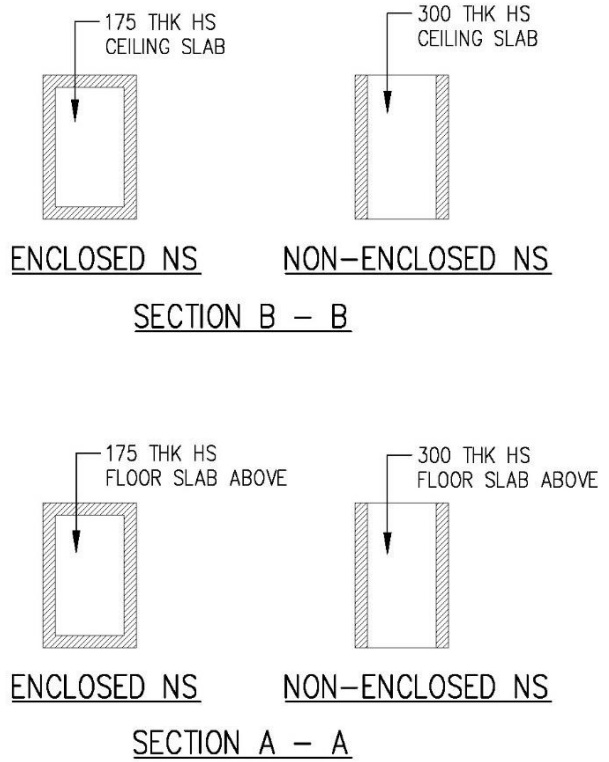

FIGURE 2.3.2 HS TOWER SHOWING HS AND NS (WITH ENCLOSED AND NON-ENCLOSED NS WALL) SLAB THICKNESS

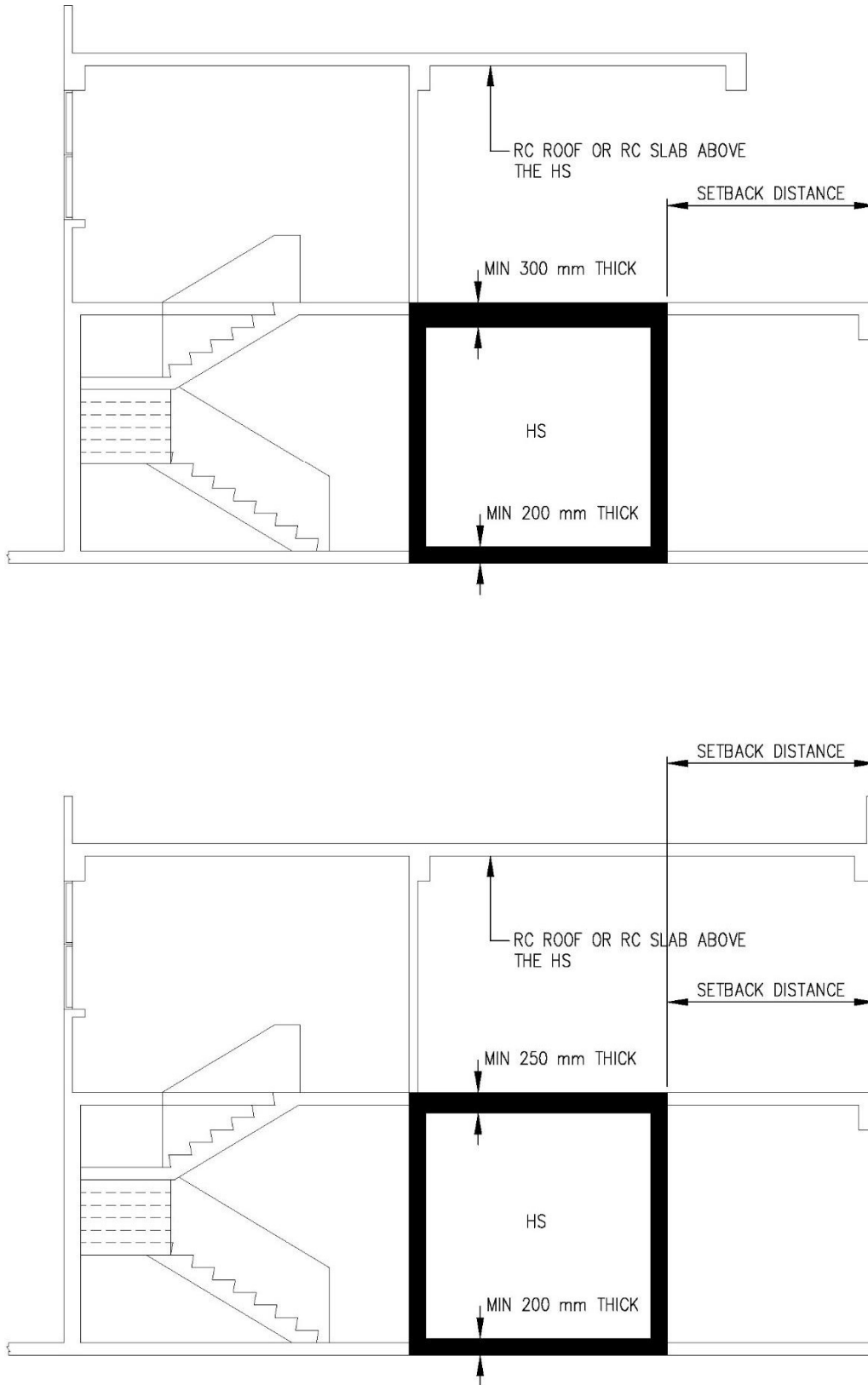
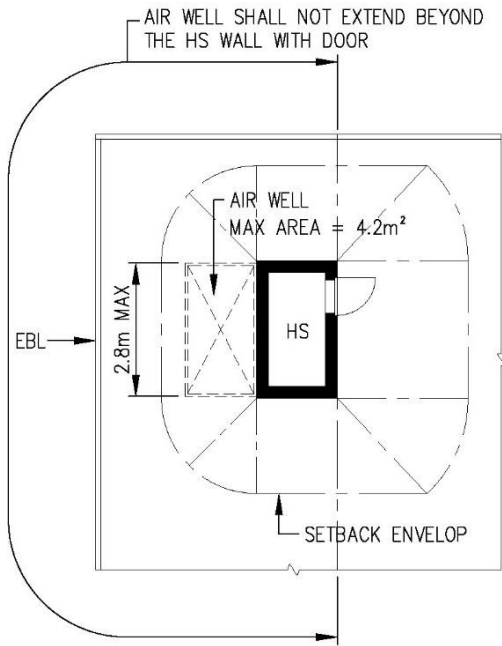
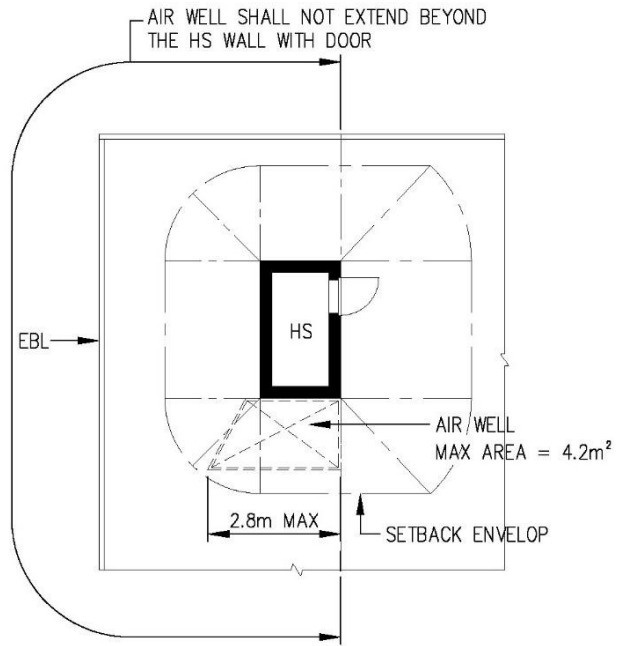

FIGURE 2.3.2(f) MINIMUM DIMENSIONS OF CEILING SLAB FOR HS IN LANDED DEVELOPMENT



PLAN A



PLAN B

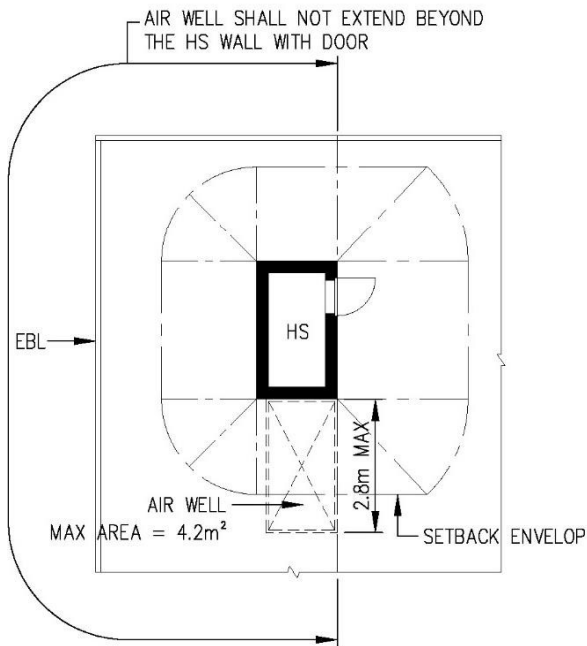

PLAN C

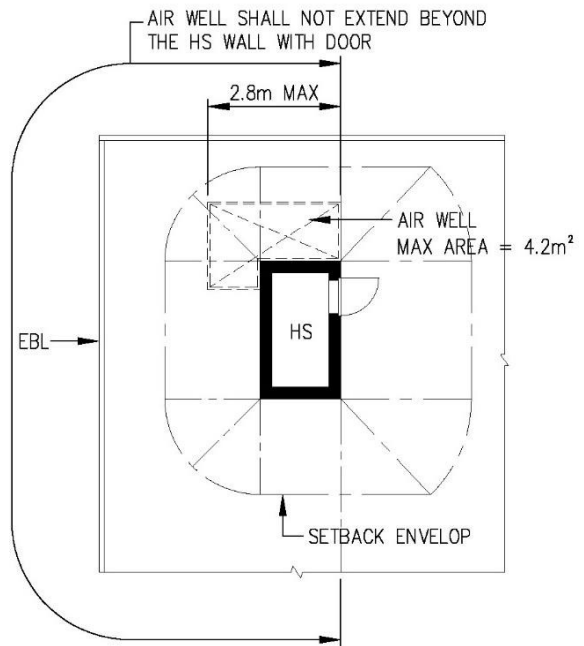

PLAN D

FIGURE 2.4.1(b) HS WALL ABUTTING AN AIR WELL IN A LANDED DEVELOPMENT

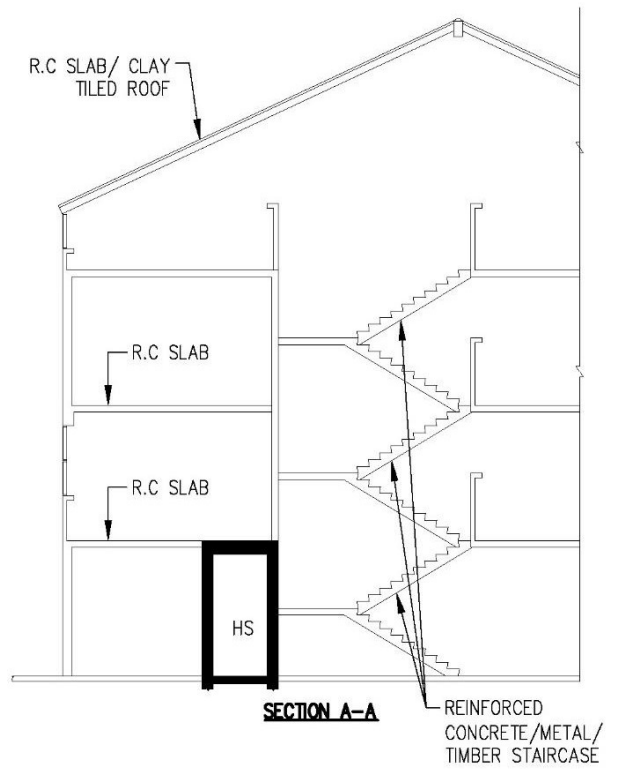
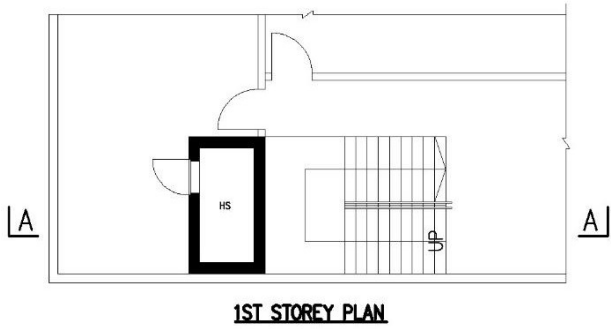
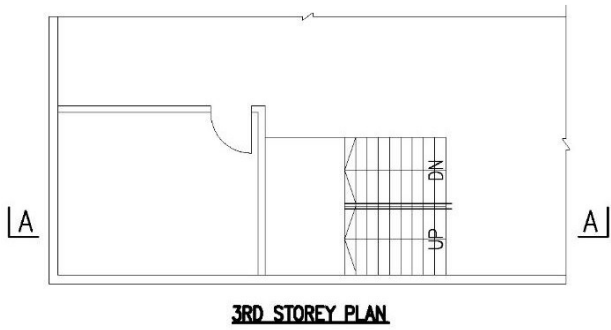
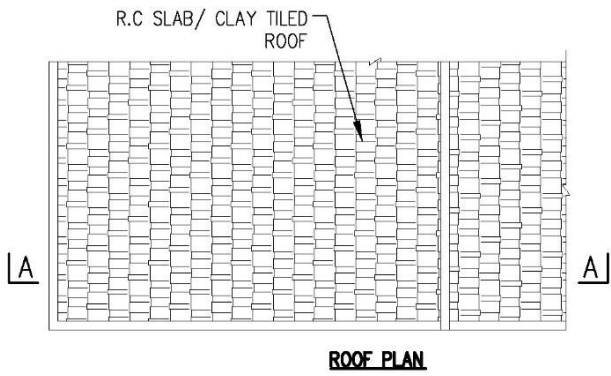

FIGURE 2.4.1c (i) RC/CLAY TILED ROOF COVER OVER STAIRCASE NEAR HS WALL IN A LANDED DEVELOPMENT

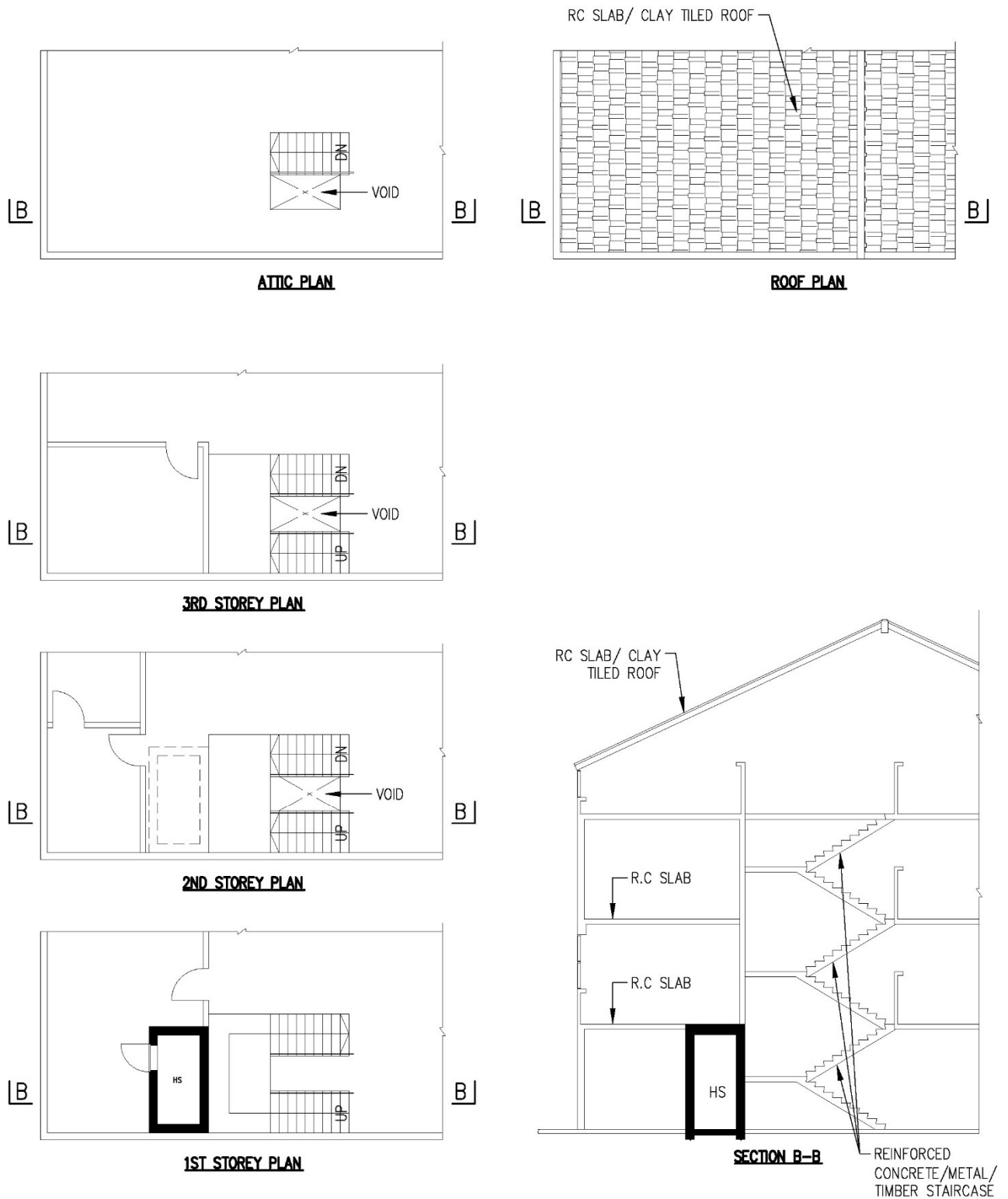
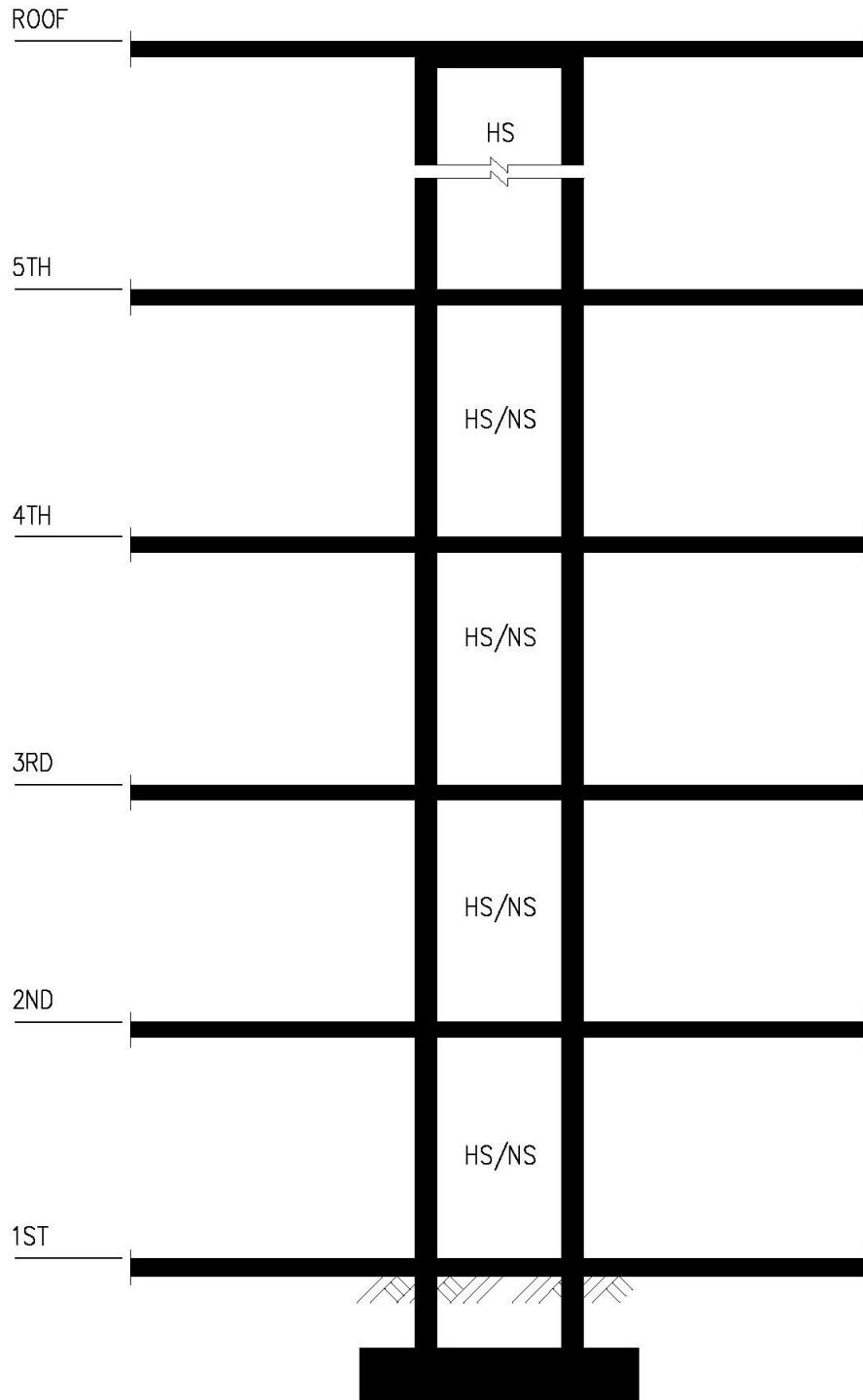

FIGURE 2.4.1c (ii) RC/CLAY TILED ROOF COVER OVER STAIRCASE (WITH VOID) NEAR HS WALL IN A LANDED DEVELOPMENT



NOTES:

1. HS TOWER WITH HS AND NS WHERE APPLICABLE

FIGURE 2.4.2(a) SCHEMATIC SECTION OF HS TOWER

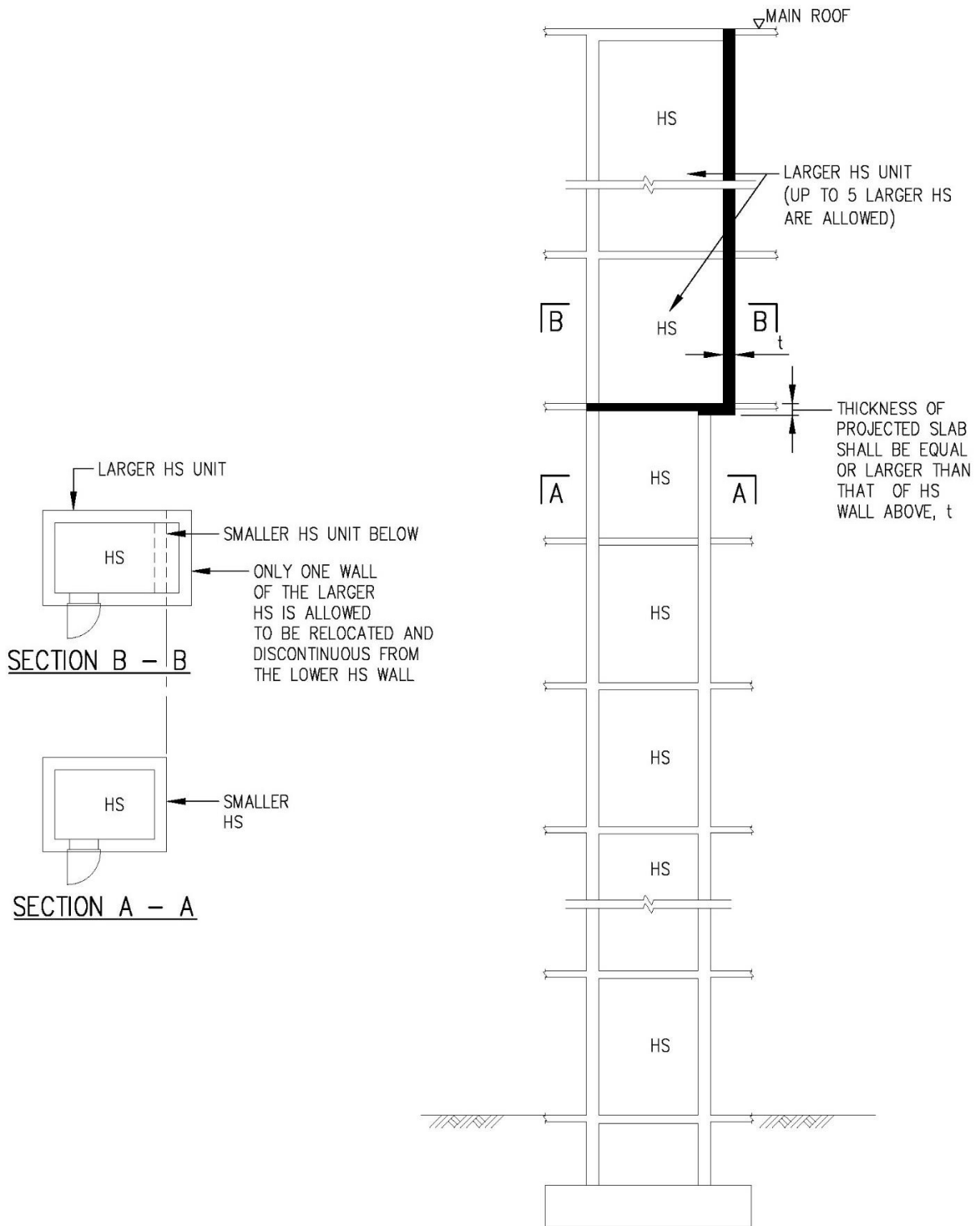
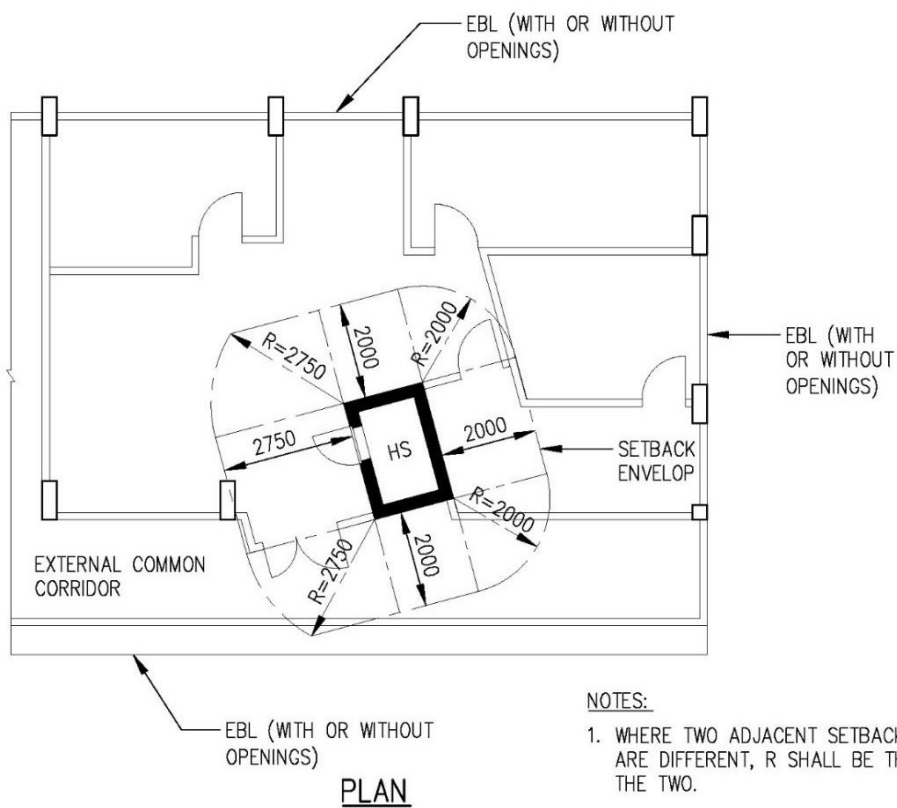
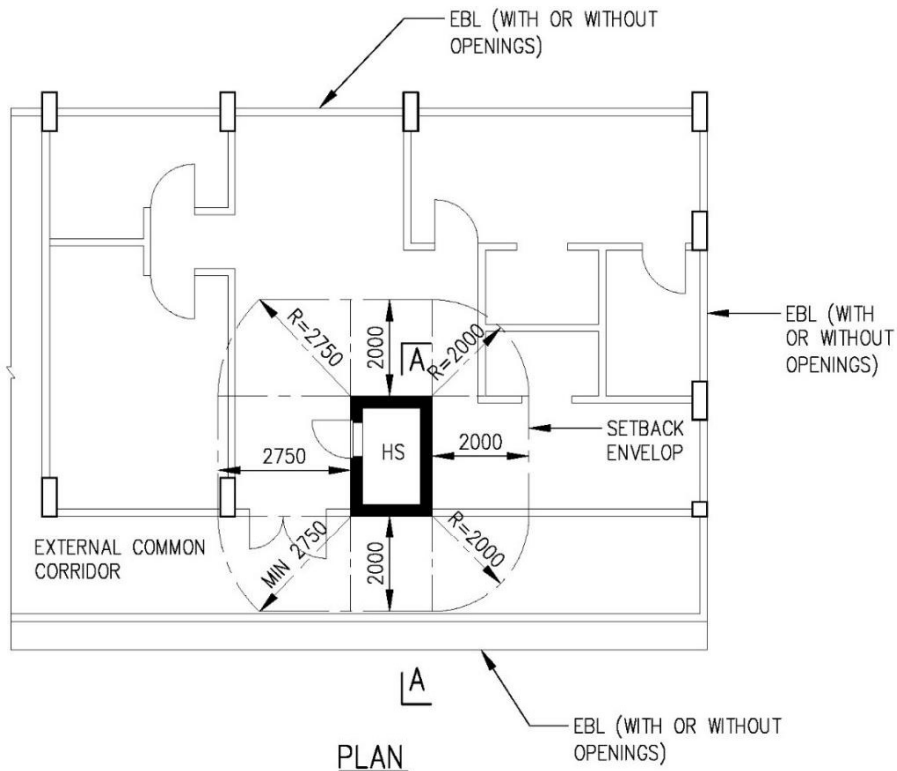

FIGURE 2.4.2(b) HS TOWER WITH LARGER HS BELOW MAIN ROOF LEVEL

TABLE 2.4.3(a): MINIMUM SETBACK DISTANCES OF HS WALLS WITHOUT REINFORCED CONCRETE DOWN-HANG BEAM ALONG EBL

S/No	Storey Height (mm) Column (1)	Setback Distance of HS Wall with HS Door (mm) Column (2)	Setback Distance of HS Walls without HS Door (mm) Column (3)
1	$2500 \leq Ht \leq 2800$	2750	2000
2	$2800 < Ht \leq 3100$	2900	2200
3	$3100 < Ht \leq 3200$	2950	2300
4	$3200 < Ht \leq 3400$	3050	2400
5	$3400 < Ht \leq 3500$	3100	2500
6	$3500 < Ht \leq 4000$	3300	2700
7	$4000 < Ht \leq 4500$	3600	2900
8	$4500 < Ht \leq 5000$	3850	3150
9	$5000 < Ht \leq 5500$	4100	3400
10	$5500 < Ht \leq 6000$	4300	3600
11	$6000 < Ht \leq 6500$	4550	3850
12	$6500 < Ht \leq 7000$	4800	4100
13	$7000 < Ht \leq 7500$	5000	4300
14	$7500 < Ht \leq 8000$	5250	4550
15	$8000 < Ht \leq 8500$	5500	4800
16	$8500 < Ht \leq 9000$	5750	5000
17	$9000 < Ht \leq 9500$	6000	5250
18	$9500 < Ht \leq 10000$	6250	5500



NOTES:

1. WHERE TWO ADJACENT SETBACK DISTANCES ARE DIFFERENT, R SHALL BE THE LARGER OF THE TWO.

FIGURE 2.4.3a (i) REQUIREMENT ON SETBACK DISTANCE OF HS WALL (WITHOUT DOWN-HANG BEAM) (STOREY HEIGHT $\leq 2800\text{MM}$) (FOR OTHER STOREY HEIGHT, SEE TABLE 2.4.3(a))

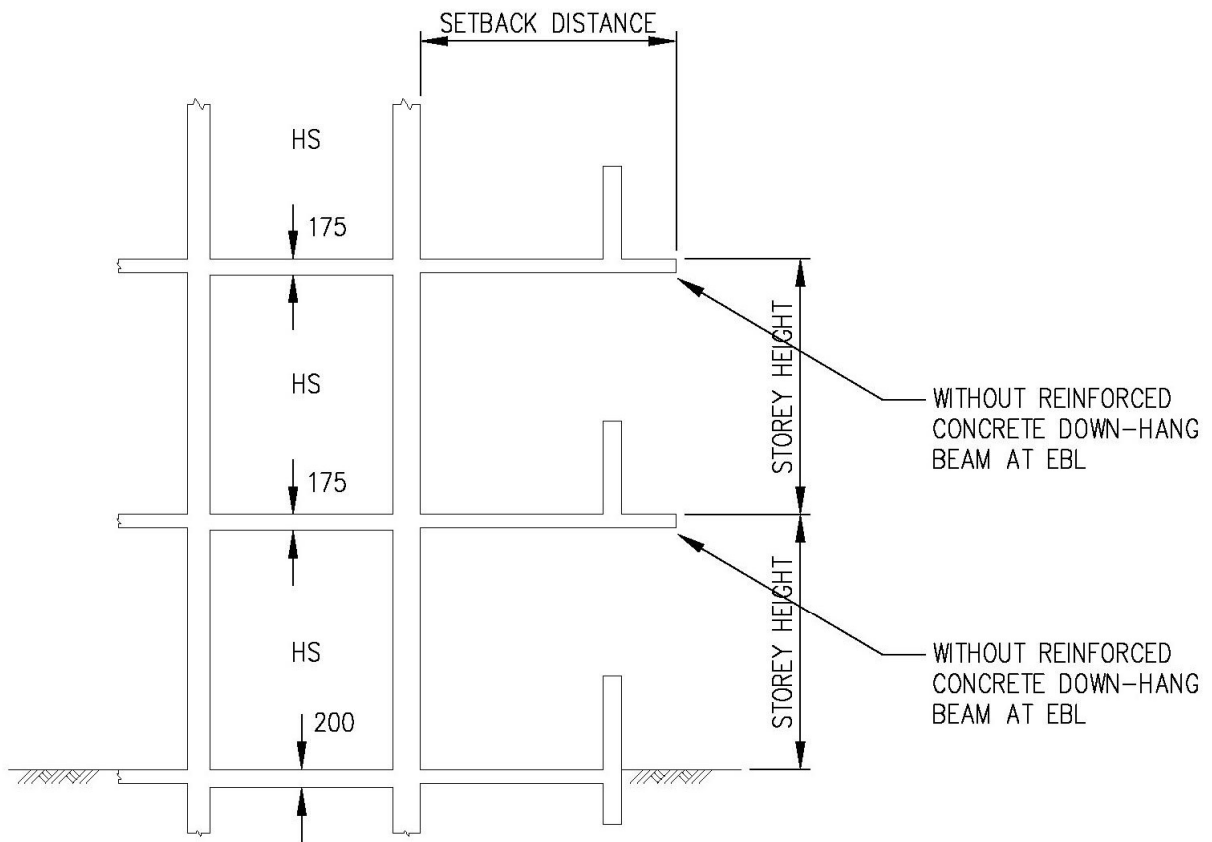

SECTION A – A

**FIGURE 2.4.3a (ii) SETBACK DISTANCE OF HS WALLS
(WITHOUT DOWN-HANG BEAM)**

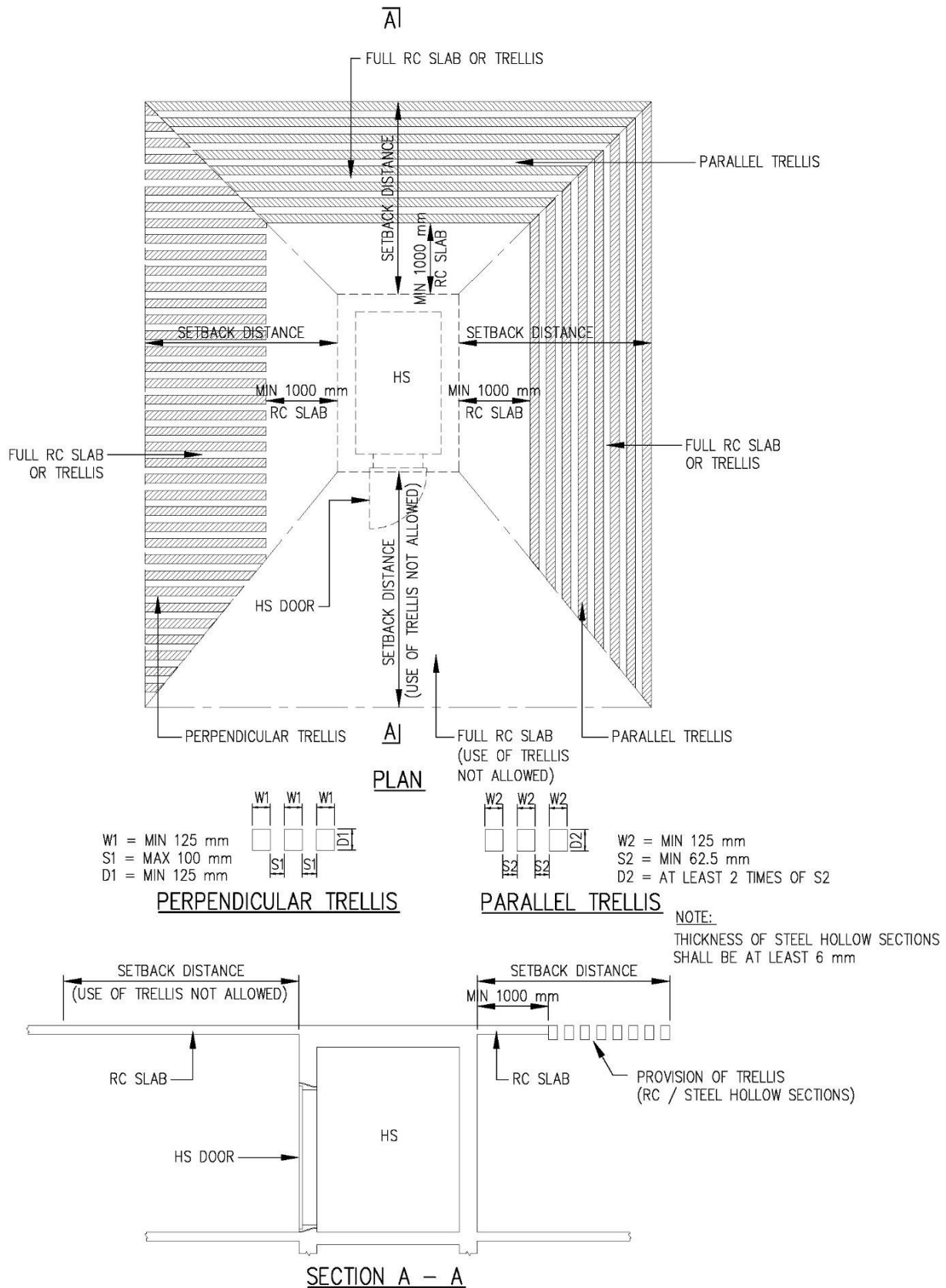
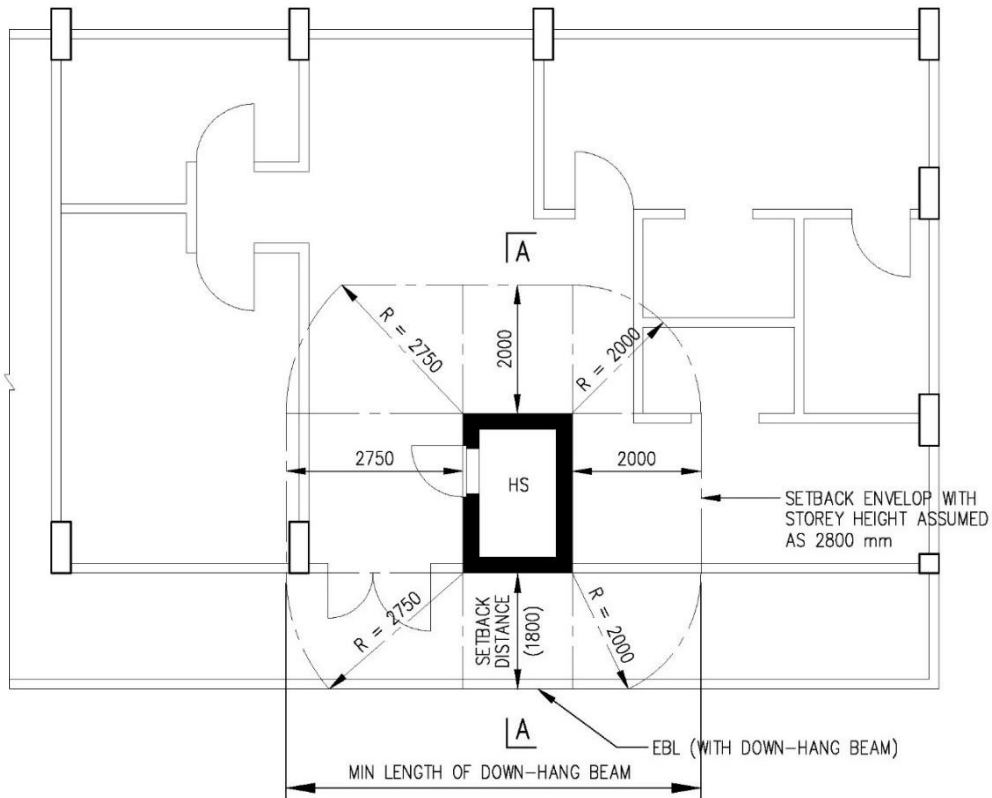

FIGURE 2.4.3(c) USAGE OF TRELLIS (RC/STEEL HOLLOW SECTIONS) TO MAKE UP FOR SHORTFALL IN SETBACK DISTANCE

TABLE 2.4.4(a): MINIMUM SETBACK DISTANCES OF HS WALLS WITH REINFORCED CONCRETE DOWN-HANG BEAM ALONG EBL

S/No	Effective Storey Height* (mm)	Setback Distance of HS Wall With HS Door (mm)	Setback Distance of HS Wall Without HS Door (mm)
	Column (1)	Column (2)	Column (3)
1	Ht < 2200	2750	1800
2	2200 ≤ Ht ≤ 2800	2750	2000
3	2800 < Ht ≤ 3100	2900	2200
4	3100 < Ht ≤ 3200	2950	2300
5	3200 < Ht ≤ 3400	3050	2400
6	3400 < Ht ≤ 3500	3100	2500
7	3500 < Ht ≤ 4000	3300	2700
8	4000 < Ht ≤ 4500	3600	2900
9	4500 < Ht ≤ 5000	3850	3150
10	5000 < Ht ≤ 5500	4100	3400
11	5500 < Ht ≤ 6000	4300	3600
12	6000 < Ht ≤ 6500	4550	3850
13	6500 < Ht ≤ 7000	4800	4100
14	7000 < Ht ≤ 7500	5000	4300
15	7500 < Ht ≤ 8000	5250	4550
16	8000 < Ht ≤ 8500	5500	4800
17	8500 < Ht ≤ 9000	5750	5000
18	9000 < Ht ≤ 9500	6000	5250
19	9500 < Ht ≤ 10000	6250	5500

*Effective Storey Height = Storey Height – Depth ‘d’ of Down-hang Beam. Refer to Figure 2.4.4(a).



PLAN
 (E.g. EFFECTIVE STOREY HEIGHT \leq 2200 mm,
 SETBACK DISTANCE = 1800 MM SEE TABLE 2.4.4(a))

NOTES:

1. WHERE TWO ADJACENT SETBACK DISTANCES ARE DIFFERENT, R SHALL BE THE LARGER OF THE TWO.

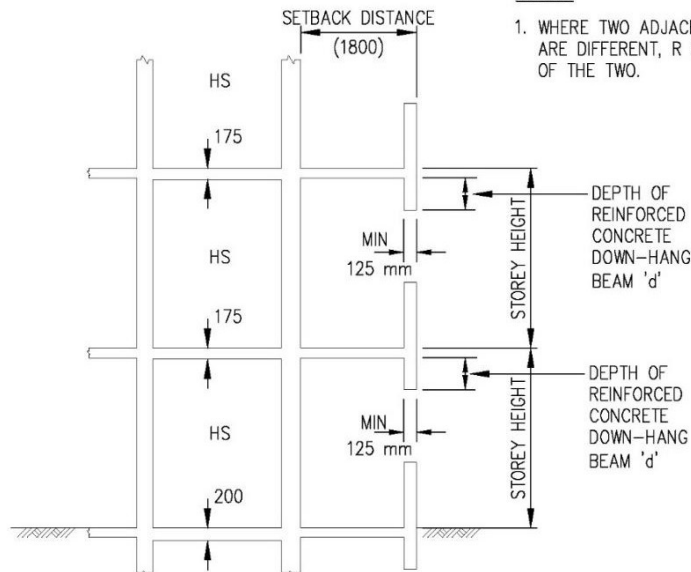

SECTION A - A

FIGURE 2.4.4(a) REQUIREMENT ON SETBACK DISTANCE OF HS WALLS (WITH DOWN-HANG BEAM)
 (EFFECTIVE STOREY HEIGHT = STOREY HEIGHT - DEPTH 'd' OF DOWN-HANG BEAM)

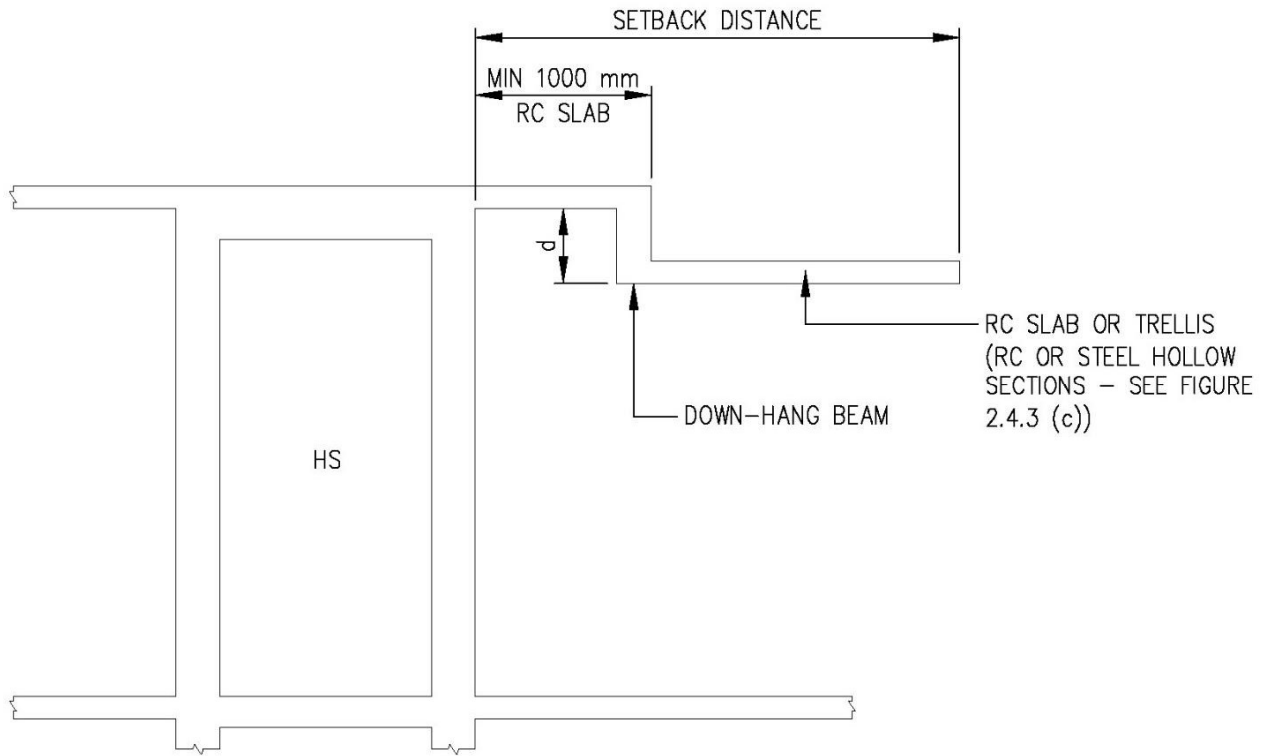
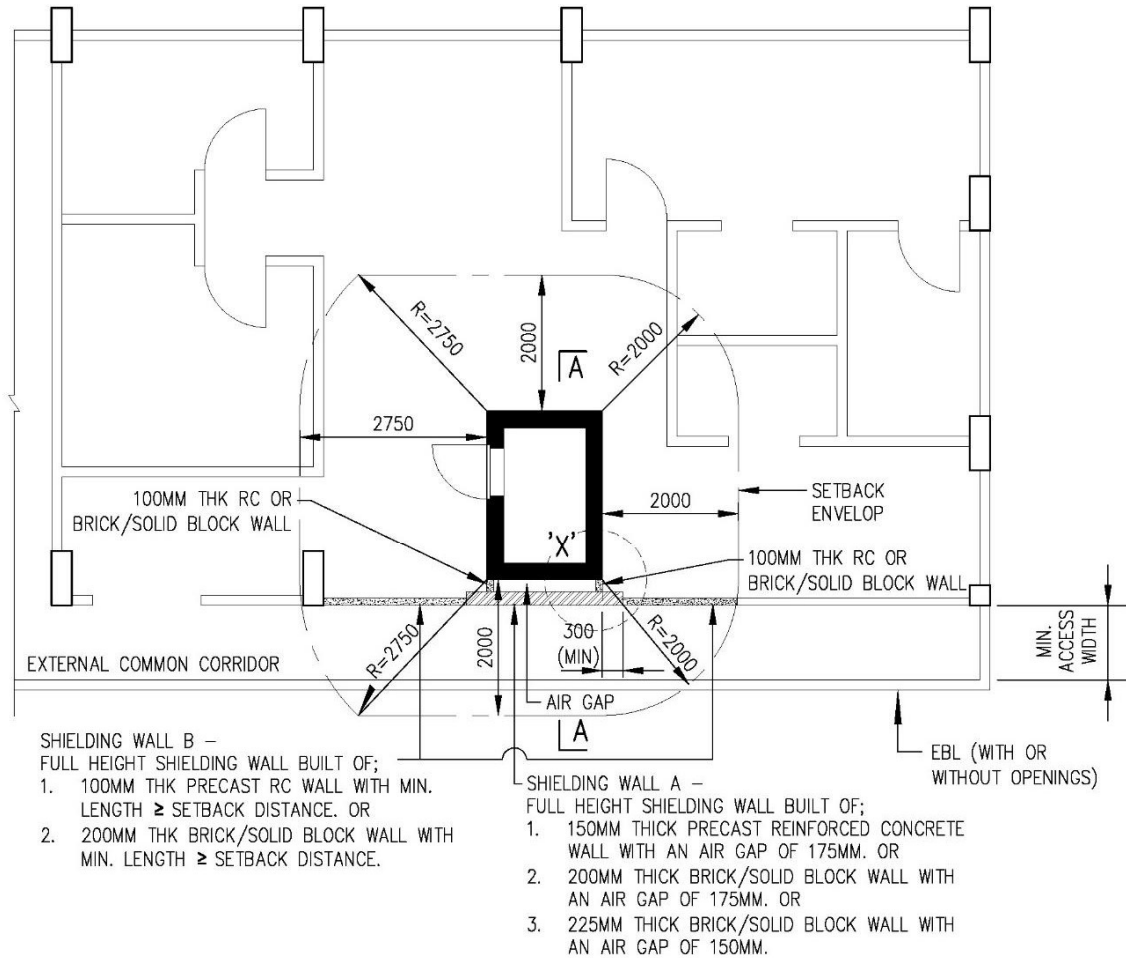

FIGURE 2.4.4(b) DOWN-HANG BEAM LOCATED AWAY FROM EXTERNAL BUILDING LINE



PLAN

(E.g. EFFECTIVE STOREY HEIGHT \leq 2800 mm)

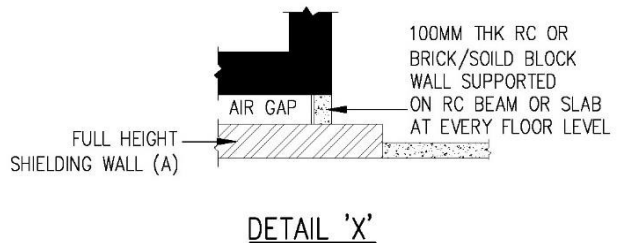
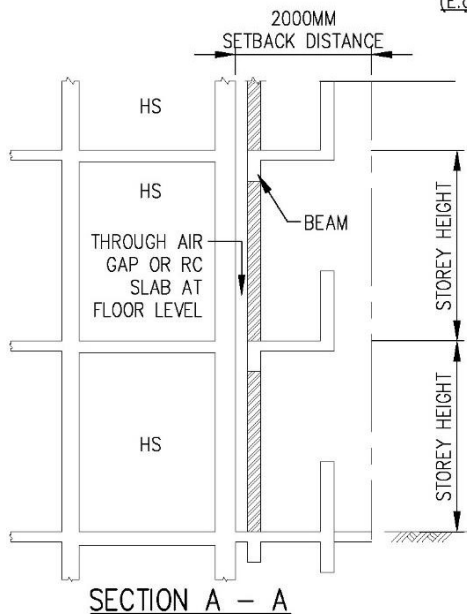
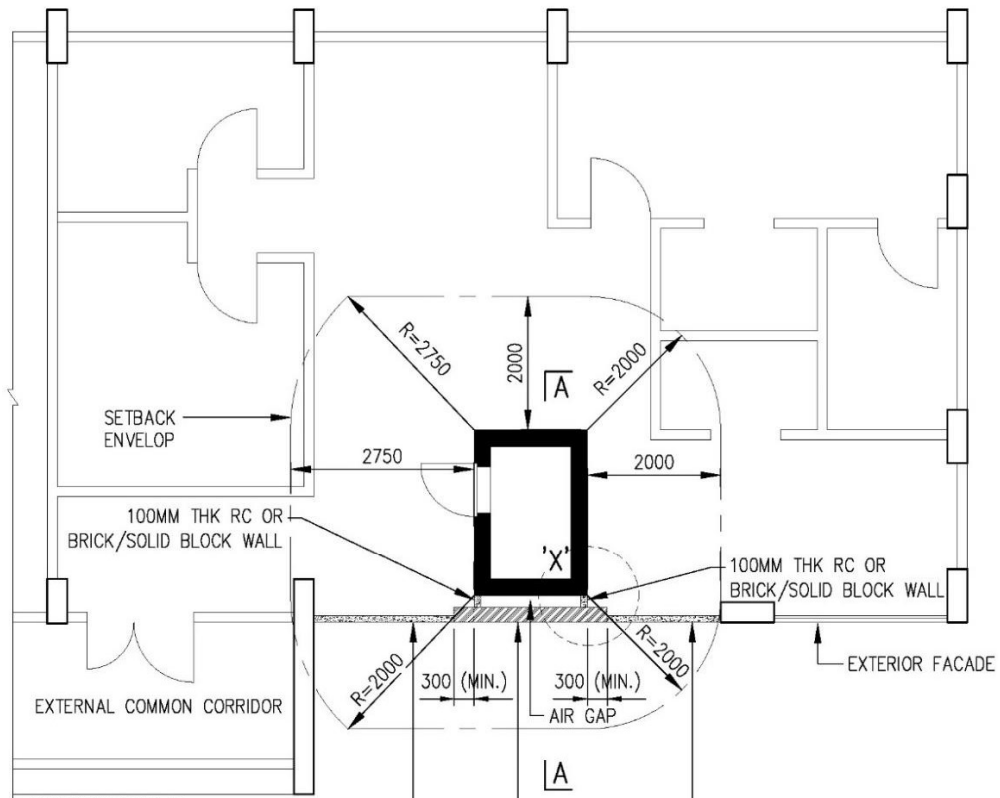

FIGURE 2.4.5(a) SHIELDING WALL “A” AND “B” FOR HS WITH SHORTFALL OF SETBACK DISTANCE ON ONE SIDE OF HS (TYPE 1A)



SHIELDING WALL B –
 FULL HEIGHT SHIELDING WALL BUILT OF;
 1. 100MM THK PRECAST RC WALL WITH MIN. LENGTH \geq SETBACK DISTANCE. OR
 2. 200MM THK BRICK/SOLID BLOCK WALL WITH MIN. LENGTH \geq SETBACK DISTANCE.

SHIELDING WALL A –
 FULL HEIGHT SHIELDING WALL BUILT OF;
 1. 150MM THICK PRECAST REINFORCED CONCRETE WALL WITH AN AIR GAP OF 175MM. OR
 2. 200MM THICK BRICK/SOLID BLOCK WALL WITH AN AIR GAP OF 175MM. OR
 3. 225MM THICK BRICK/SOLID BLOCK WALL WITH AN AIR GAP OF 150MM.

PLAN

(E.g. EFFECTIVE STOREY HEIGHT \leq 2800 mm)

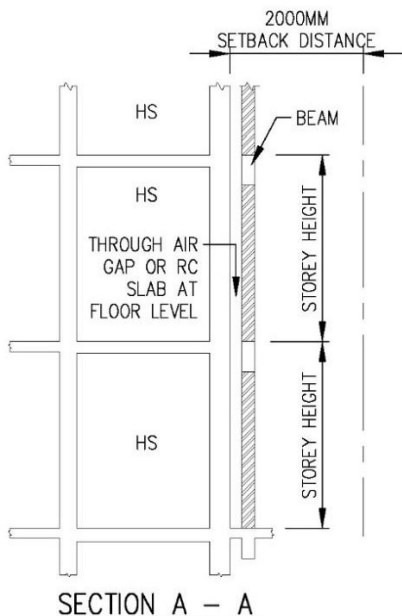

SECTION A – A

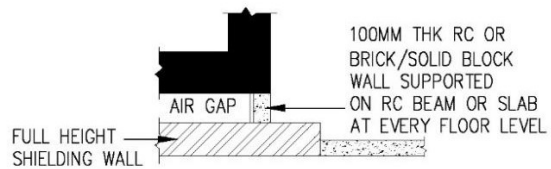

DETAIL 'X'

FIGURE 2.4.5(b) SHIELDING WALL “A” AND “B” FOR HS WITH SHORTFALL OF SETBACK DISTANCE ON ONE SIDE OF HS (TYPE 1B)

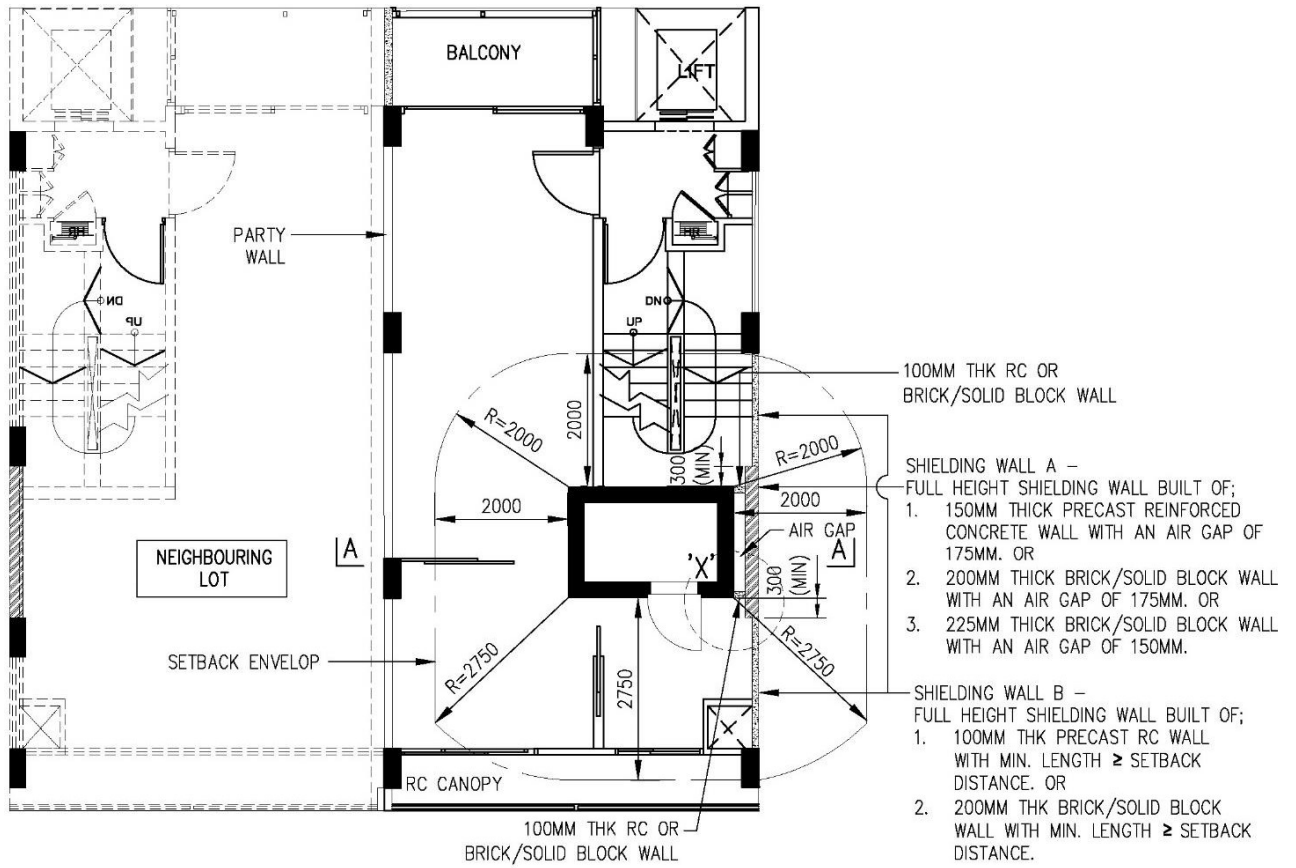

PLAN

(E.g. EFFECTIVE STOREY HEIGHT \leq 2800 mm)

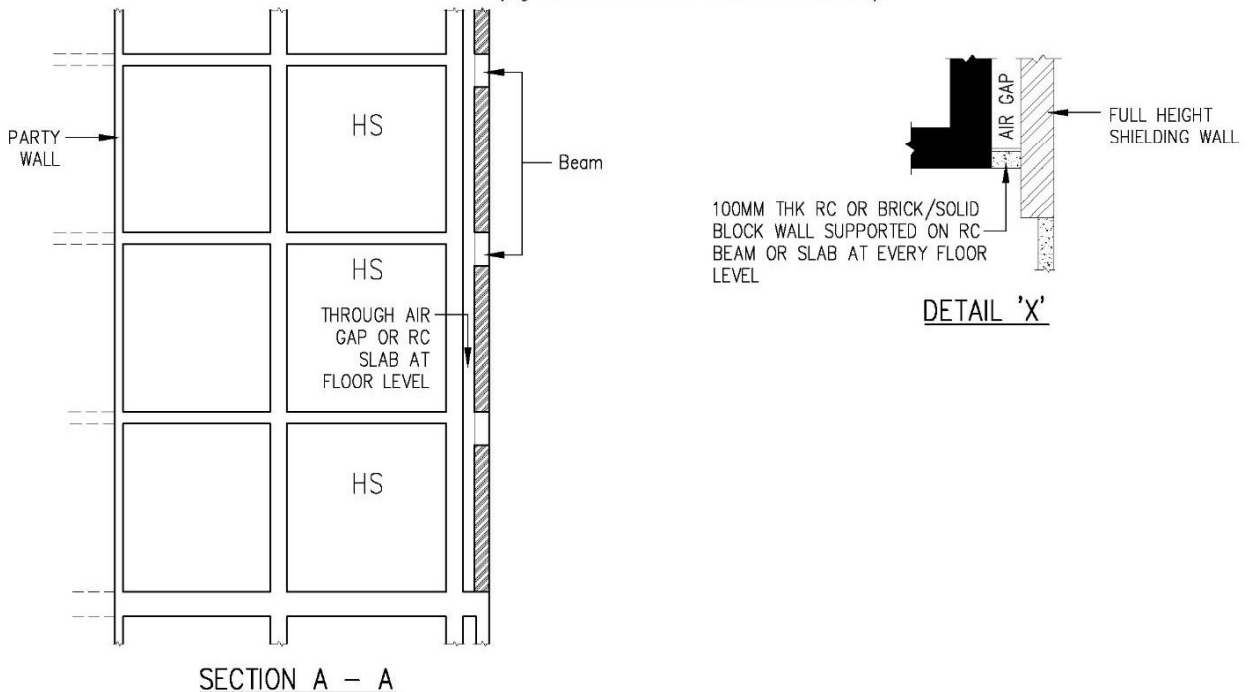
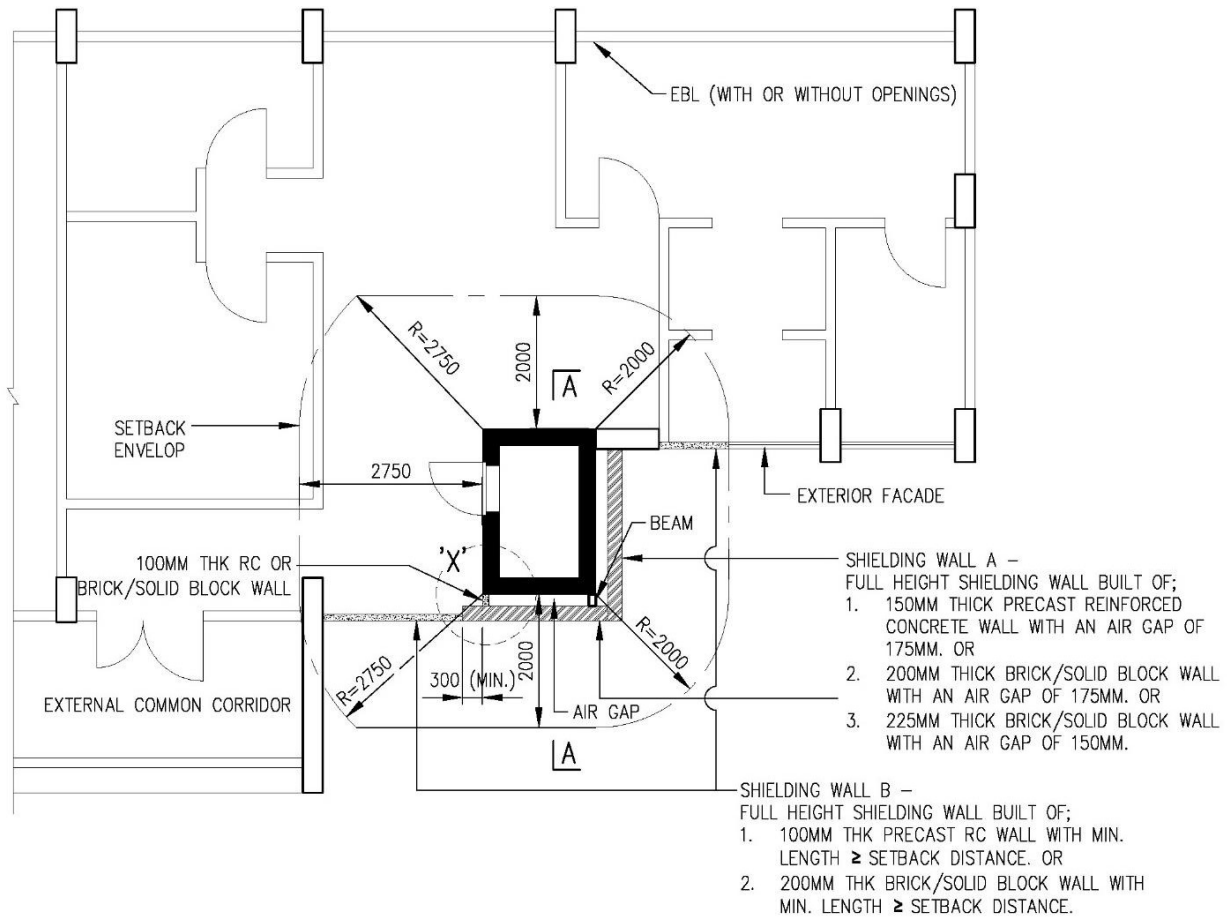

FIGURE 2.4.5(c) SHIELDING WALL “A” AND “B” FOR HS WITH SHORTFALL OF SETBACK DISTANCE ON ONE SIDE OF HS (TYPE 1C)



PLAN

(E.g. EFFECTIVE STOREY HEIGHT \leq 2800 mm)

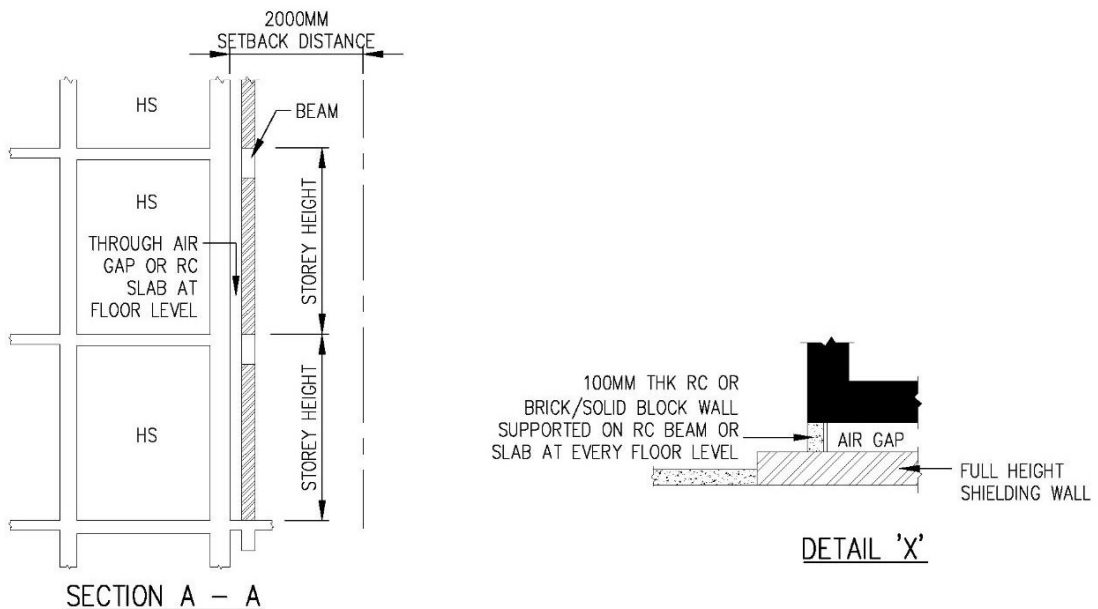

FIGURE 2.4.5(d) SHIELDING WALL “A” AND “B” FOR HS WITH SHORTEALL OF SETBACK DISTANCE ON TWO SIDES OF HS (TYPE 2A)

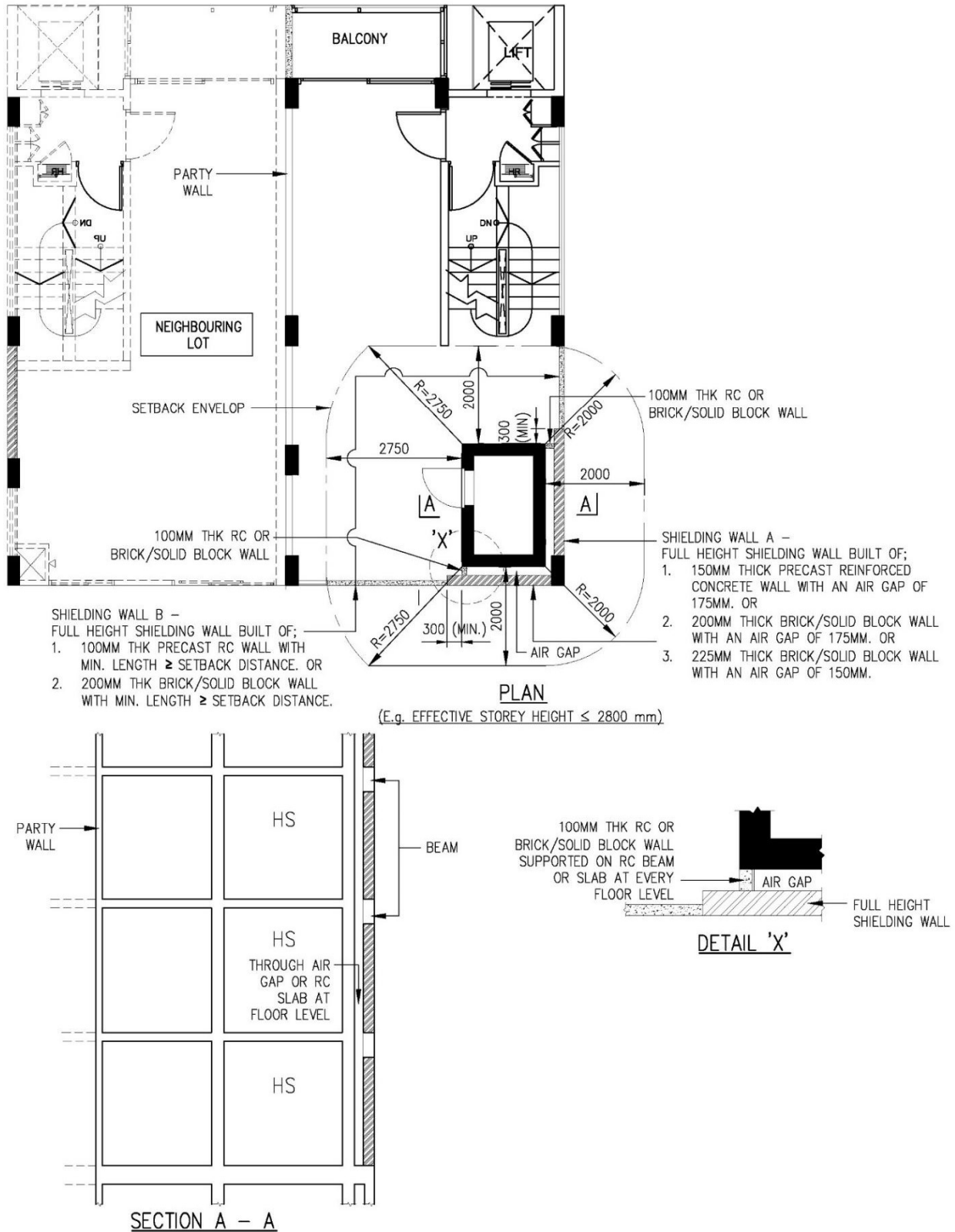
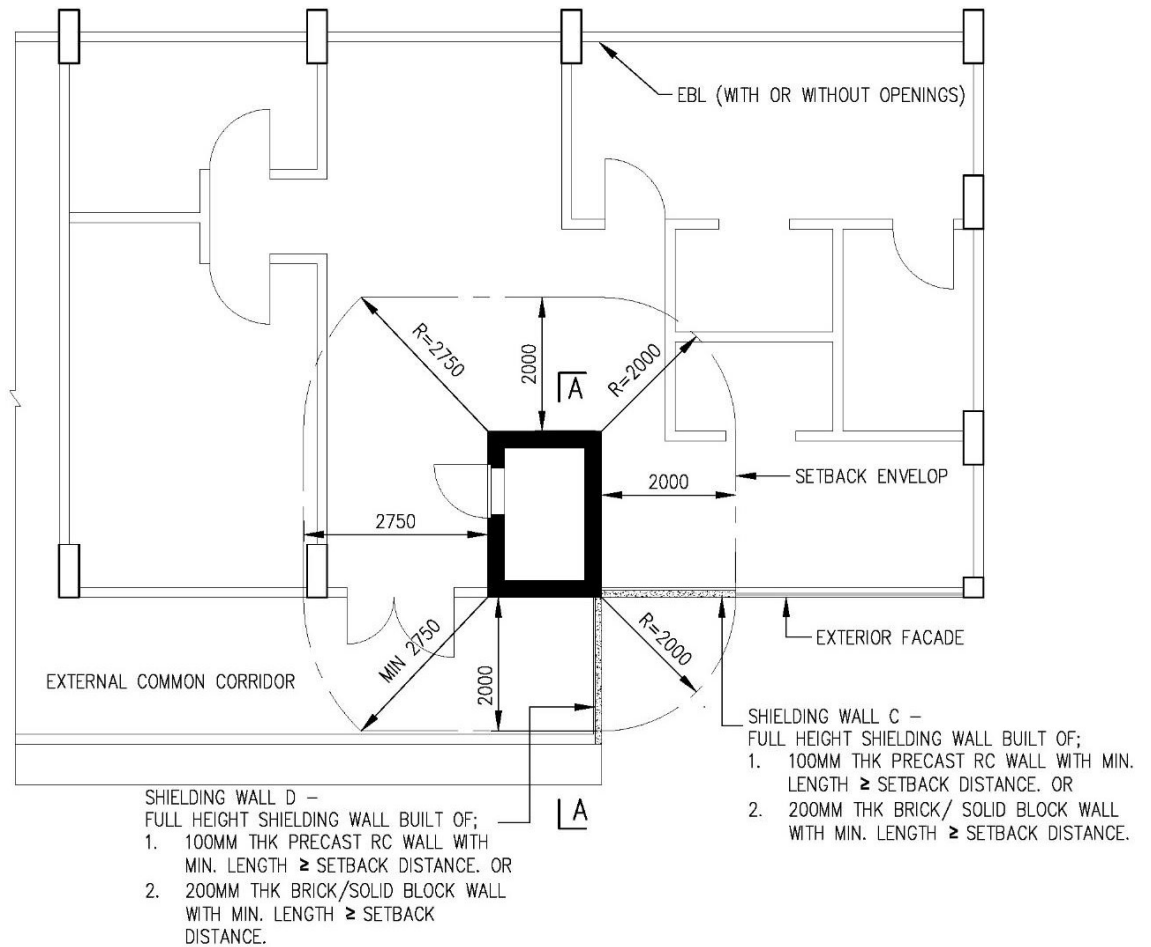
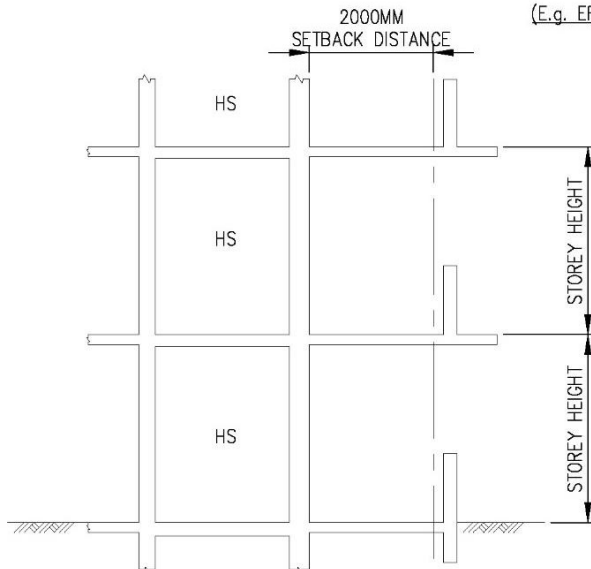

FIGURE 2.4.5(e) SHIELDING WALL “A” AND “B” FOR HS WITH SHORTFALL OF SETBACK DISTANCE ON TWO SIDES OF HS (TYPE 2B)



PLAN

(E.g. EFFECTIVE STOREY HEIGHT \leq 2800 mm)



SECTION A – A

FIGURE 2.4.5(f) SHIELDING WALL “C” AND “D” FOR HS WITH SHORTFALL OF SETBACK DISTANCE AT ONE CORNER OF HS (TYPE 3A)

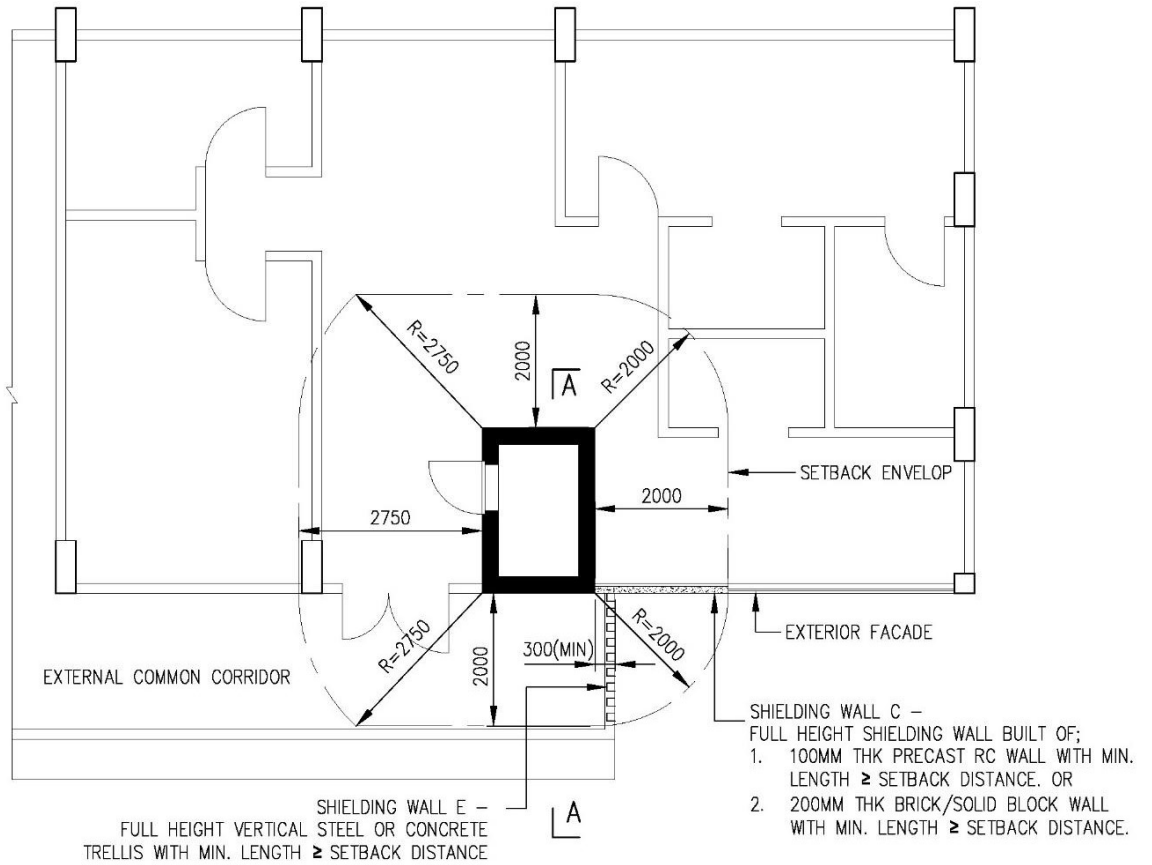

PLAN

(E.g. EFFECTIVE STOREY HEIGHT \leq 2800 mm).

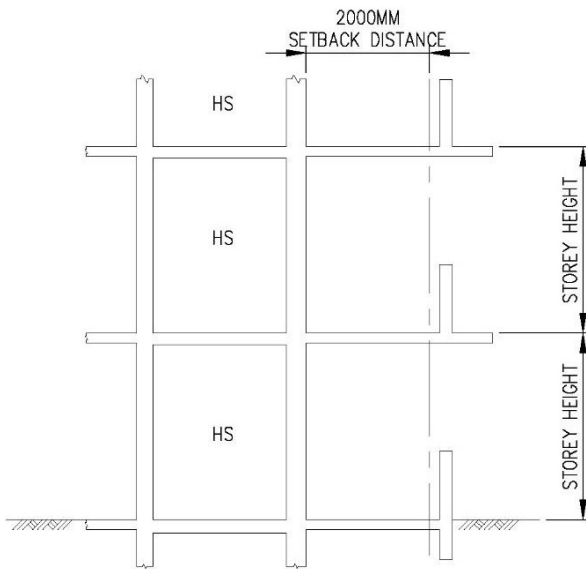

SECTION A – A

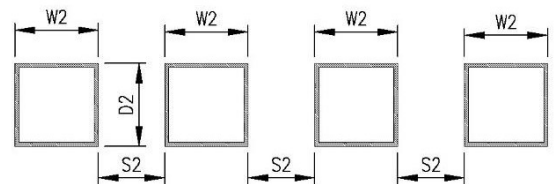

W2 = MIN 125MM
 S2 = MAX 100MM
 D2 = MIN 125MM

NOTE:
 IF STEEL TRELIS IS USED,
 MINIMUM THICKNESS OF STEEL
 HOLLOW SECTION IS 6MM

PLAN VIEW OF VERTICAL CONCRETE OR STEEL TRELIS

FIGURE 2.4.5(g) SHIELDING WALL “C” AND “E” FOR HS WITH SHORTFALL OF SETBACK DISTANCE AT ONE CORNER OF HS (TYPE 3B)

**TABLE 2.4.6(a): MINIMUM SETBACK DISTANCES OF BASEMENT HS WALLS
(FACING REINFORCED CONCRETE BASEMENT STOREY WALLS WITH OPENING)**

S/No	Storey Height (mm) Column (1)	Setback Distance of HS Wall with HS Door (mm) Column (2)	Setback Distance of HS Walls without HS Door (mm) Column (3)
1	$2500 \leq Ht \leq 2800$	2750	2000
2	$2800 < Ht \leq 3100$	2900	2200
3	$3100 < Ht \leq 3200$	2950	2300
4	$3200 < Ht \leq 3400$	3050	2400
5	$3400 < Ht \leq 3500$	3100	2500
6	$3500 < Ht \leq 4000$	3300	2700
7	$4000 < Ht \leq 4500$	3600	2900
8	$4500 < Ht \leq 5000$	3850	3150
9	$5000 < Ht \leq 5500$	4100	3400
10	$5500 < Ht \leq 6000$	4300	3600
11	$6000 < Ht \leq 6500$	4550	3850
12	$6500 < Ht \leq 7000$	4800	4100
13	$7000 < Ht \leq 7500$	5000	4300
14	$7500 < Ht \leq 8000$	5250	4550
15	$8000 < Ht \leq 8500$	5500	4800
16	$8500 < Ht \leq 9000$	5750	5000
17	$9000 < Ht \leq 9500$	6000	5250
18	$9500 < Ht \leq 10000$	6250	5500

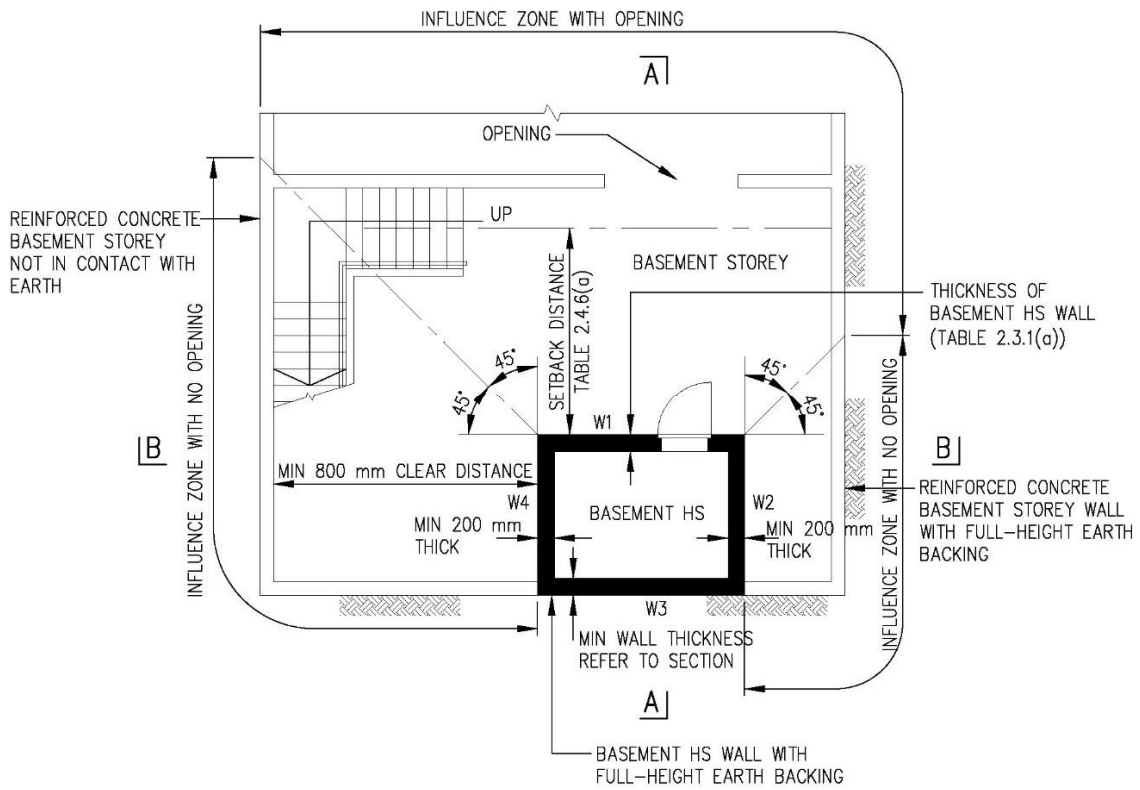
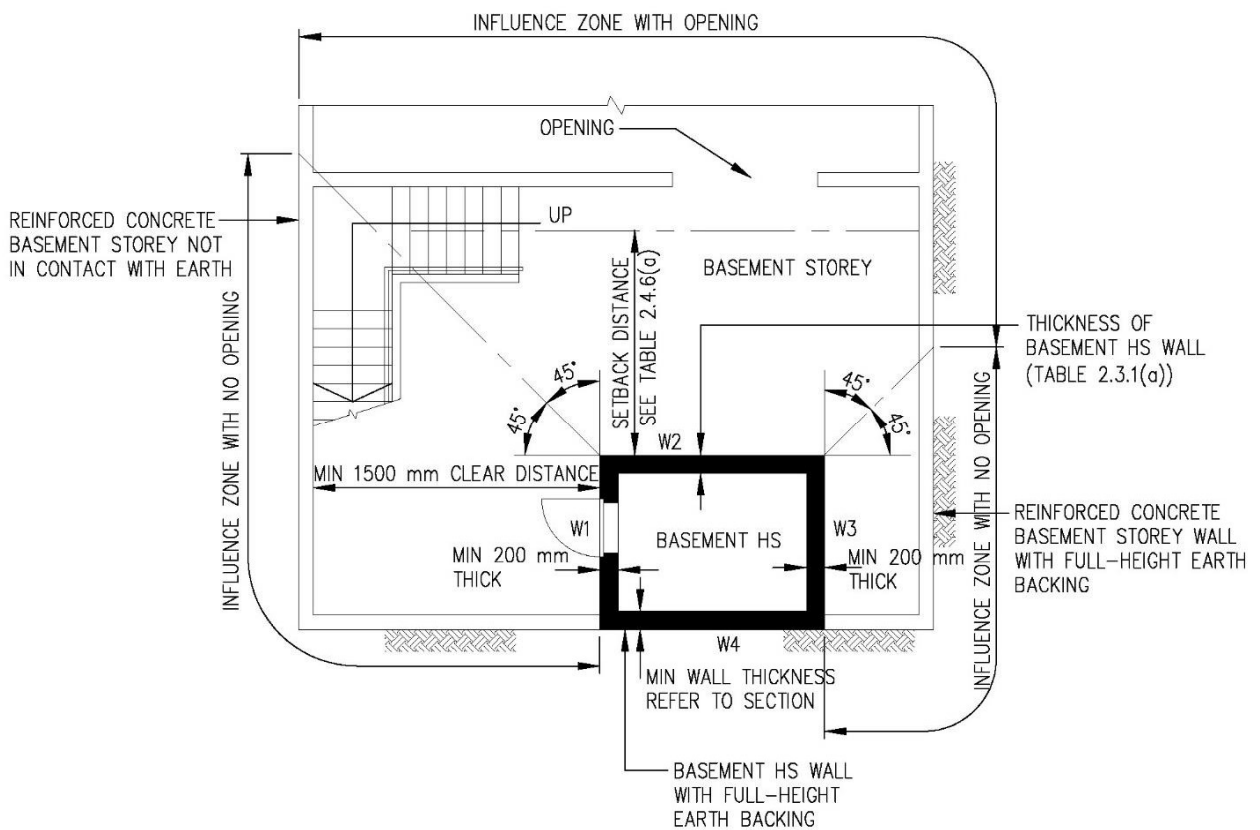
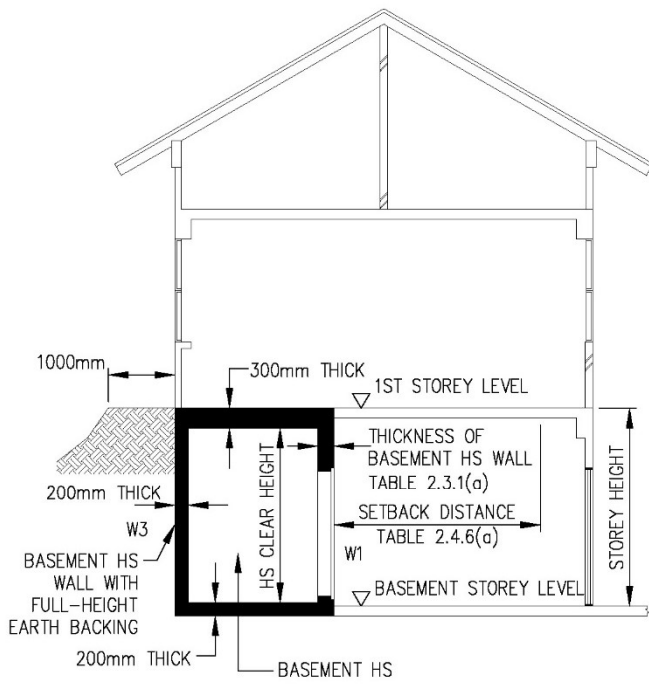

FIGURE 2.4.6(a) PLAN OF A BASEMENT HS

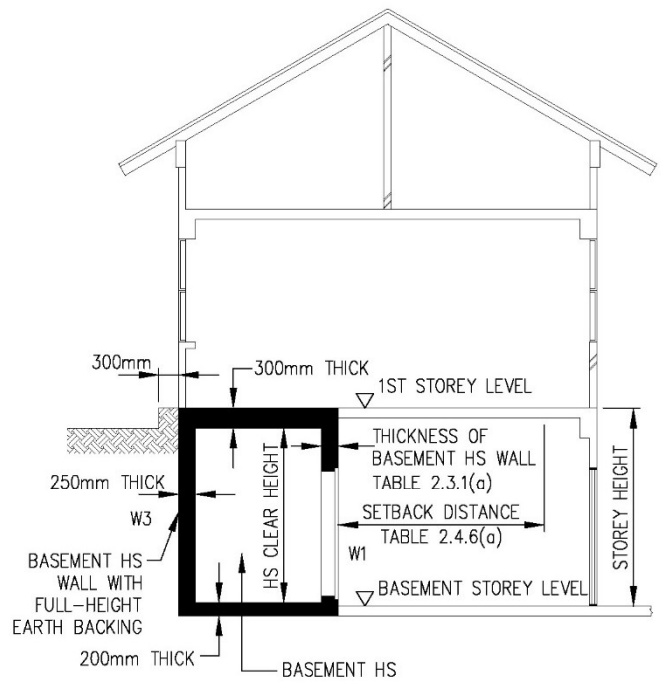

**FIGURE 2.4.6(b) PLAN OF A BASEMENT HS
(WITH HS DOOR FACES RC BASEMENT WALL)**



SECTION A - A

(E.g. EARTH BACKING OF MINIMUM 1000 mm)



SECTION A - A

(E.g. EARTH BACKING OF MINIMUM 300 mm)

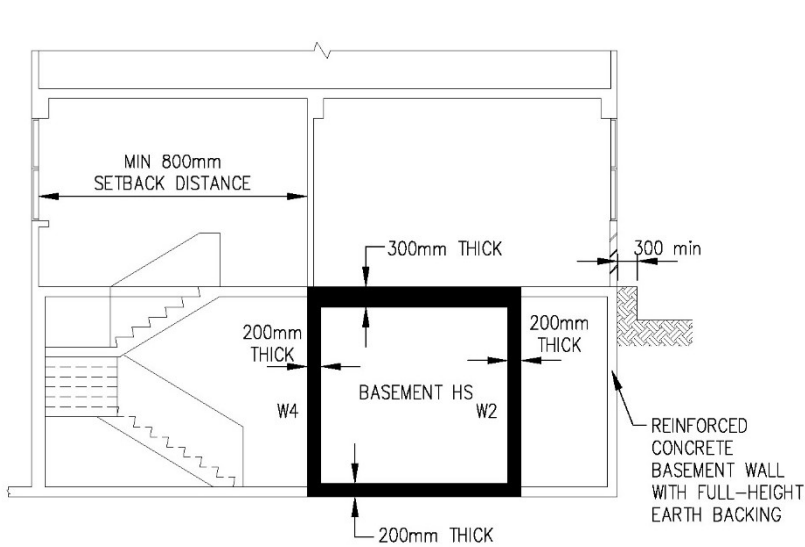

SECTION B - B

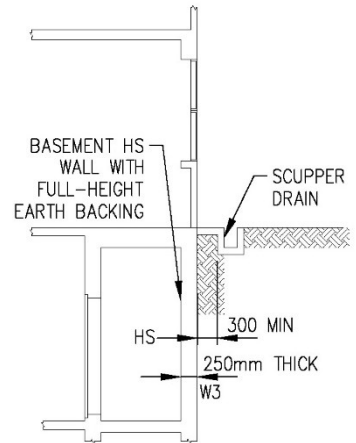

BASEMENT WALL WITH EARTH BACKING AND SCUPPER DRAIN

FIGURE 2.4.6(c) SECTIONAL VIEW OF A BASEMENT HS

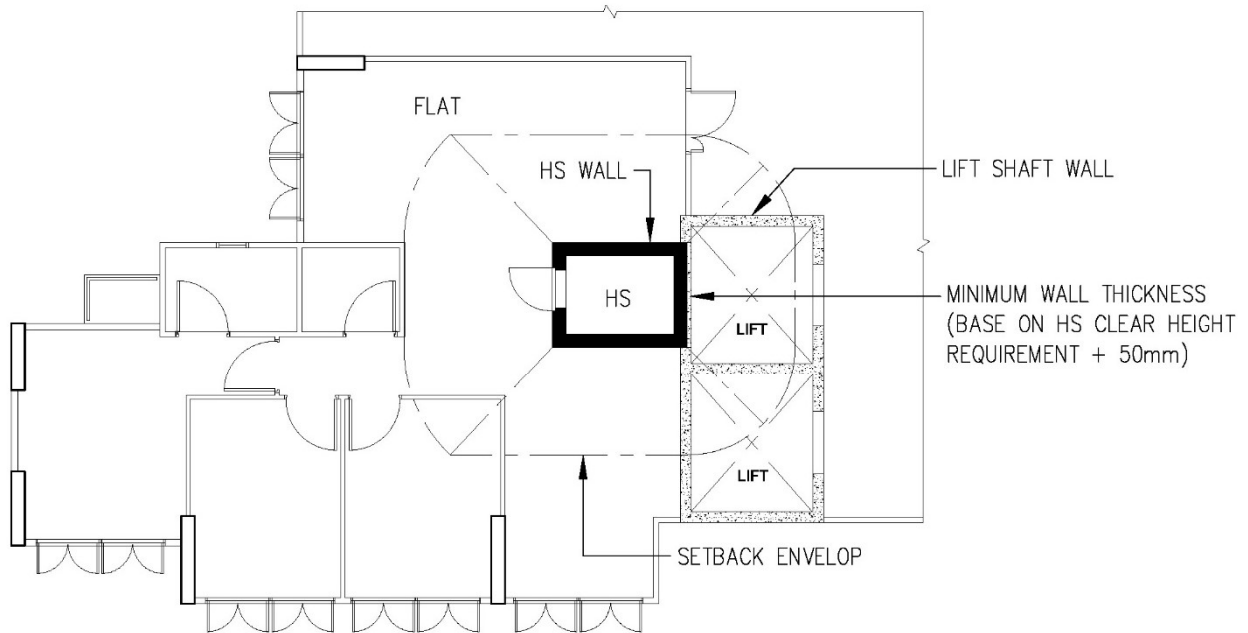

PLAN

FIGURE 2.4.7a HS LOCATED NEXT TO LIFT SHAFT

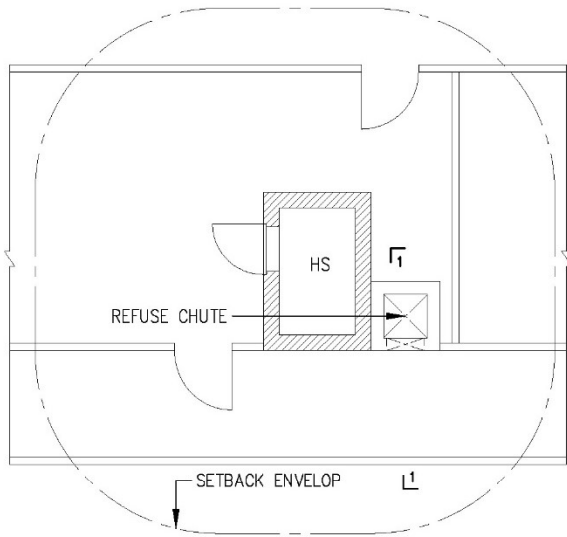

TYPICAL SHELTER PART PLAN WITH REFUSE CHUTE ABUTTING HS

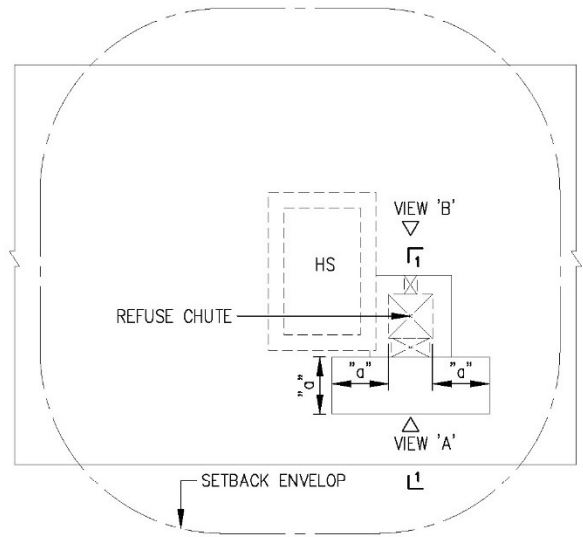

TYPICAL SHELTER ROOF PART PLAN WITH REFUSE CHUTE ABUTTING HS

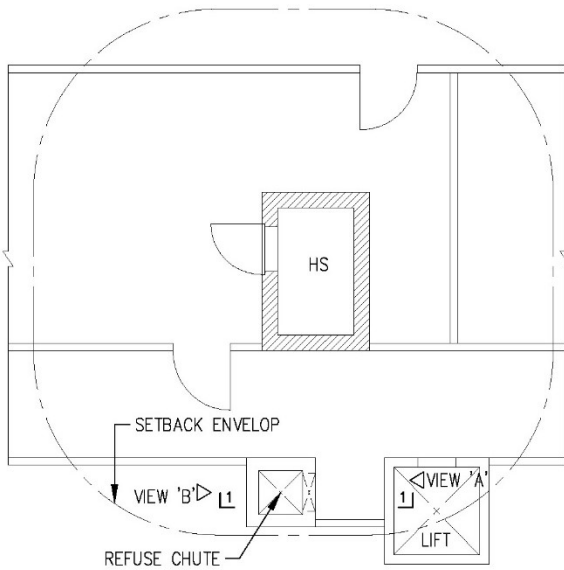

TYPICAL SHELTER PART PLAN WITH REFUSE CHUTE WITHIN SETBACK ENVELOPE HS

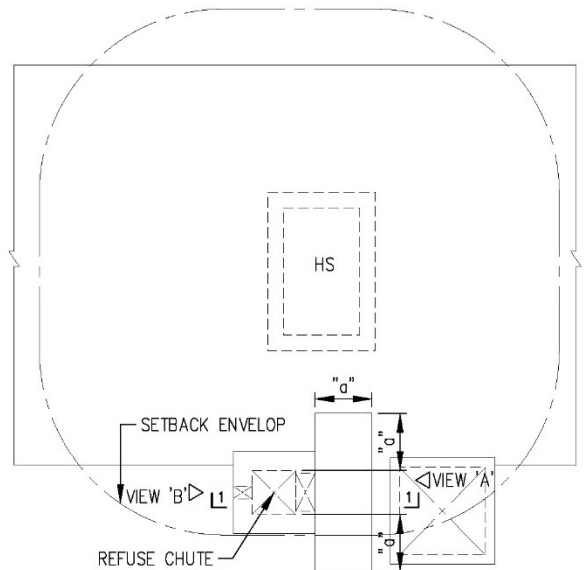

TYPICAL SHELTER ROOF PART PLAN WITH REFUSE CHUTE WITHIN SETBACK ENVELOPE HS

FIGURE 2.4.7b (i) PROTECTION REQUIREMENT AT ROOF LEVEL FOR PROVISION OF RC REFUSE CHUTE LOCATED WITHIN SETBACK DISTANCE ENVELOPE

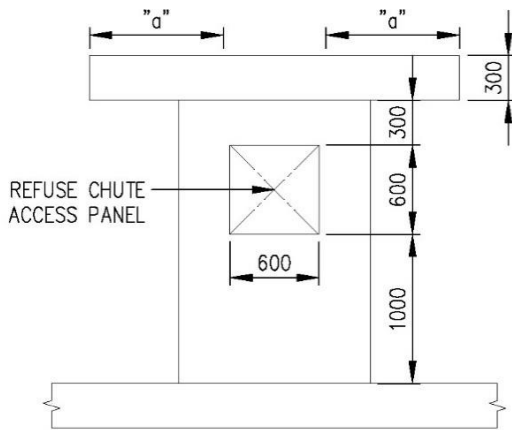

**RC REFUSE CHUTE
PROTECTION VIEW 'A'**

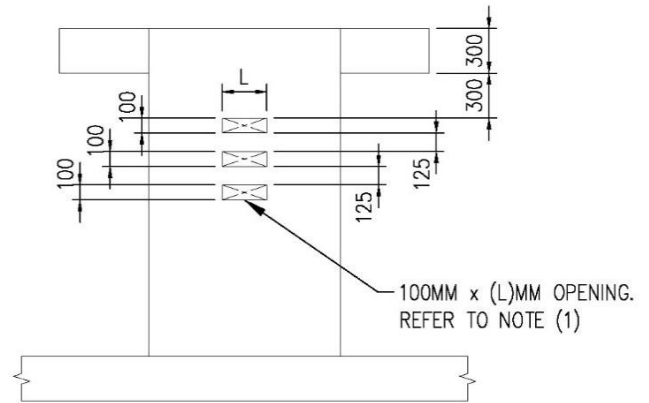

**RC REFUSE CHUTE
PROTECTION VIEW 'B'**

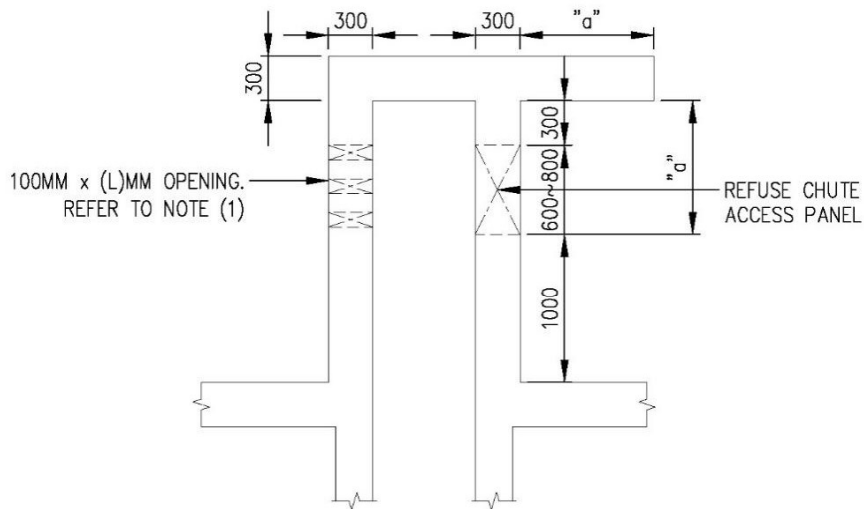

**RC REFUSE CHUTE
PROTECTION SECTION 1-1**

NOTE (1): TOTAL AREA OF OPENING FOR REFUSE CHUTE VENTING SHALL BE DESIGNED AND PROVIDED TO MEET THE STATUTORY FUNCTIONAL REQUIREMENTS.

FIGURE 2.4.7b (ii) REQUIREMENTS FOR PROTRUDING OF REFUSE CHUTE ABOVE THE ROOF

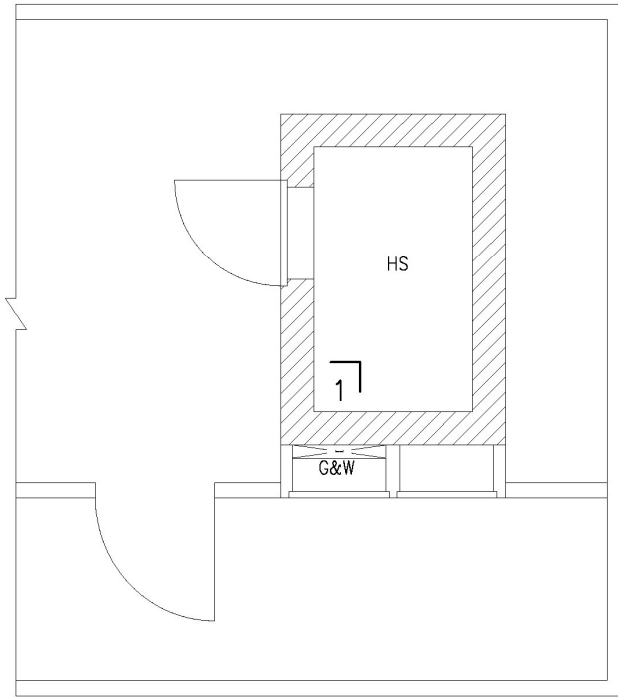

1-1

TYPICAL SHELTER PART PLAN OF GAS AND WATER OPENING WITH ELBOW (TYPE A)

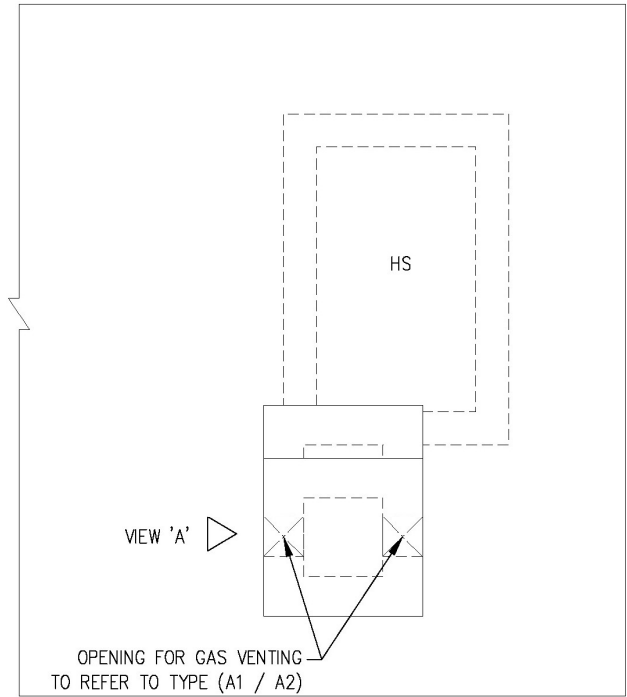

VIEW 'A'

OPENING FOR GAS VENTING TO REFER TO TYPE (A1 / A2)

TYPICAL SHELTER PART ROOF PLAN OF GAS AND WATER OPENING WITH ELBOW (TYPE A)

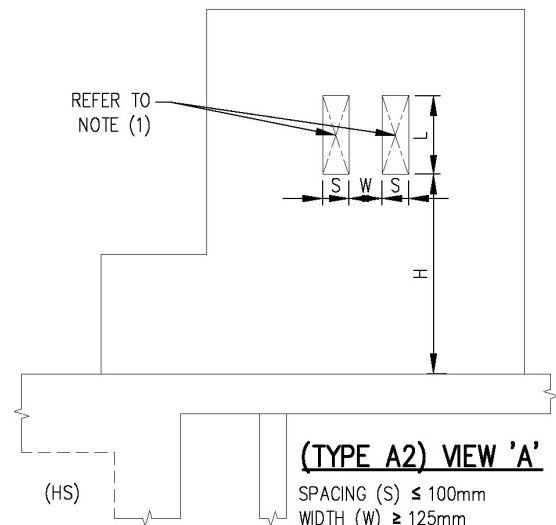
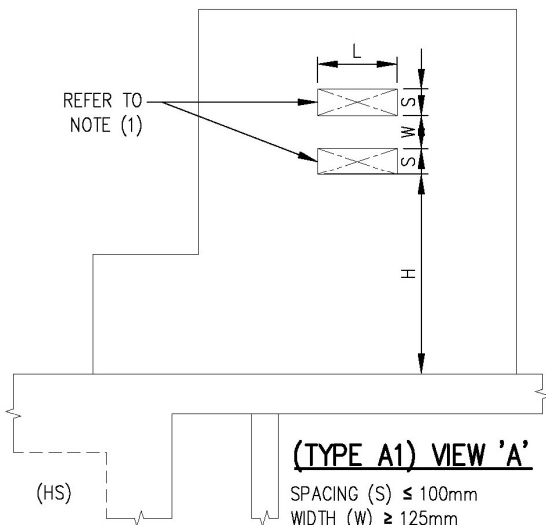

NOTE (1): TOTAL AREA OF OPENING FOR GAS VENTING SHALL BE DESIGNED AND PROVIDED TO MEET THE STATUTORY FUNCTIONAL REQUIREMENTS.

FIGURE 2.4.7c (i) REQUIREMENTS FOR PROTRUDING OF RISER ABOVE THE ROOF (TYPE A)

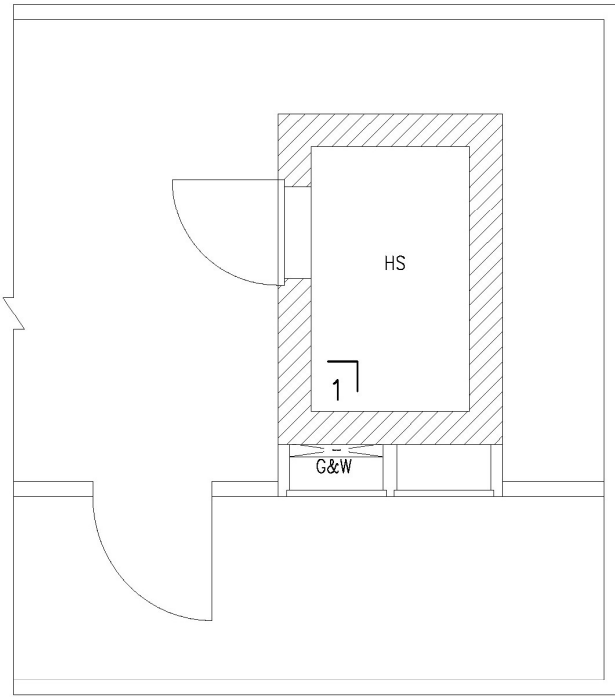

TYPICAL SHELTER PART PLAN OF GAS AND WATER OPENING WITHOUT ELBOW (TYPE B)

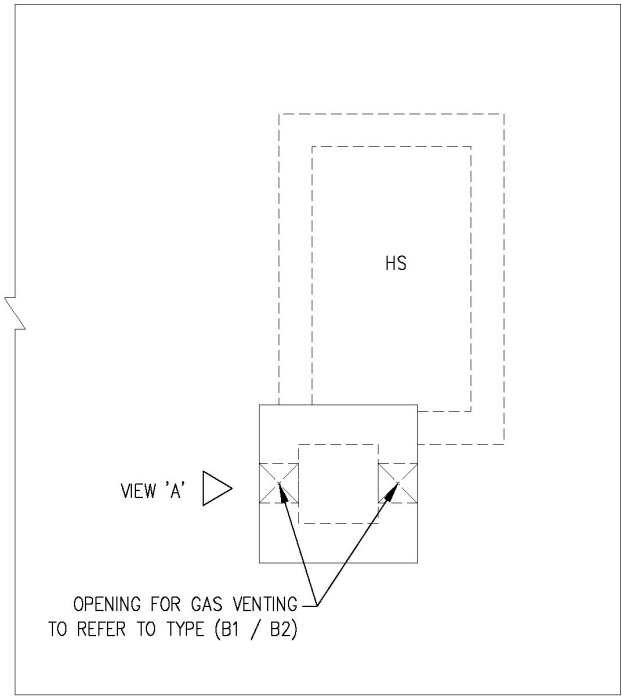

TYPICAL SHELTER PART ROOF PLAN OF GAS AND WATER OPENING WITHOUT ELBOW (TYPE B)

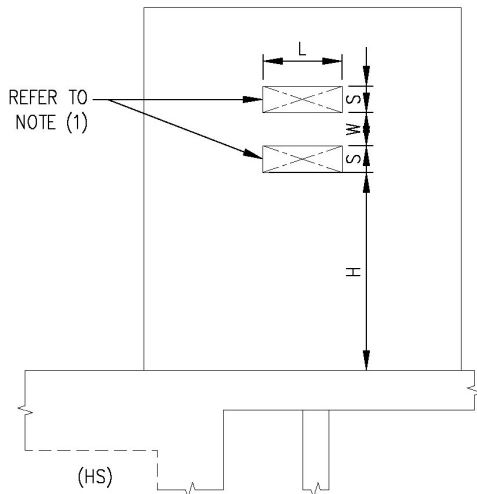

(TYPE B1) VIEW 'A'

SPACING (S) ≤ 100mm
 WIDTH (W) ≥ 125mm
 HEIGHT (H) ≥ 1000mm

NOTE (1): TOTAL AREA OF OPENING FOR GAS VENTING SHALL BE DESIGNED AND PROVIDED TO MEET THE STATUTORY FUNCTIONAL REQUIREMENTS.

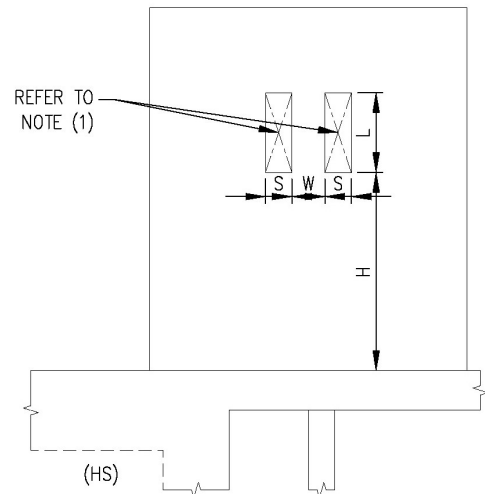

(TYPE B2) VIEW 'A'

SPACING (S) ≤ 100mm
 WIDTH (W) ≥ 125mm
 HEIGHT (H) ≥ 1000mm

FIGURE 2.4.7c (ii) REQUIREMENTS FOR PROTRUDING OF RISER ABOVE THE ROOF (TYPE B)

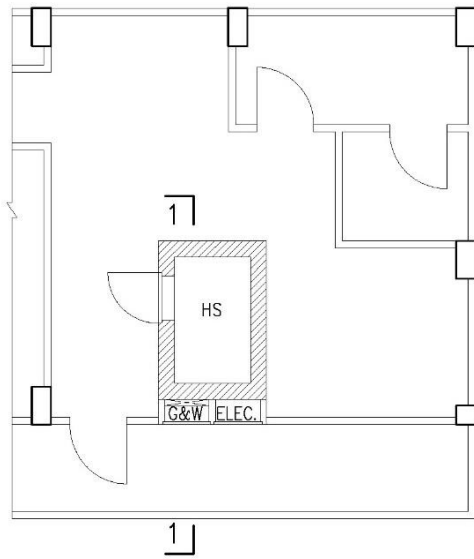

TYPICAL FLOOR PLAN

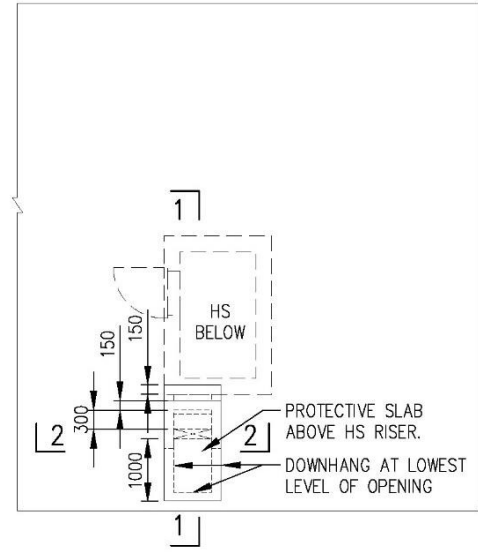

TYPICAL ROOF PLAN

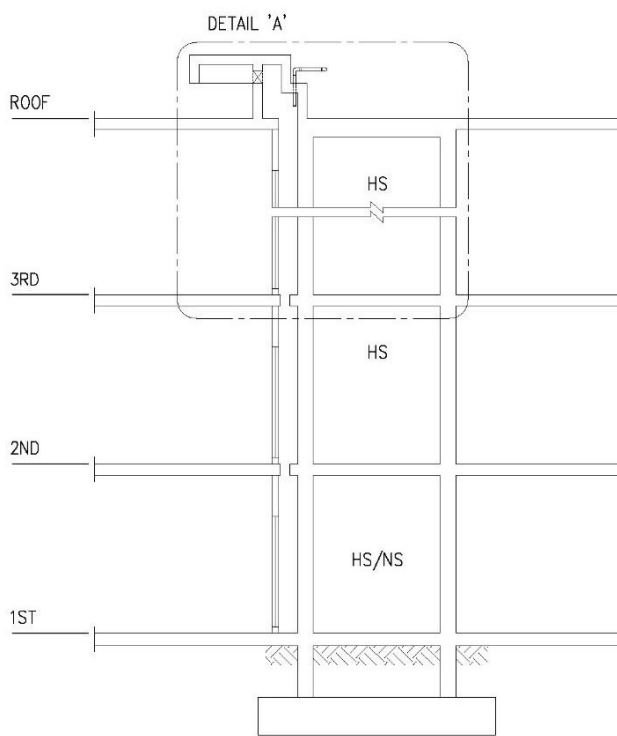

SECTION 1-1

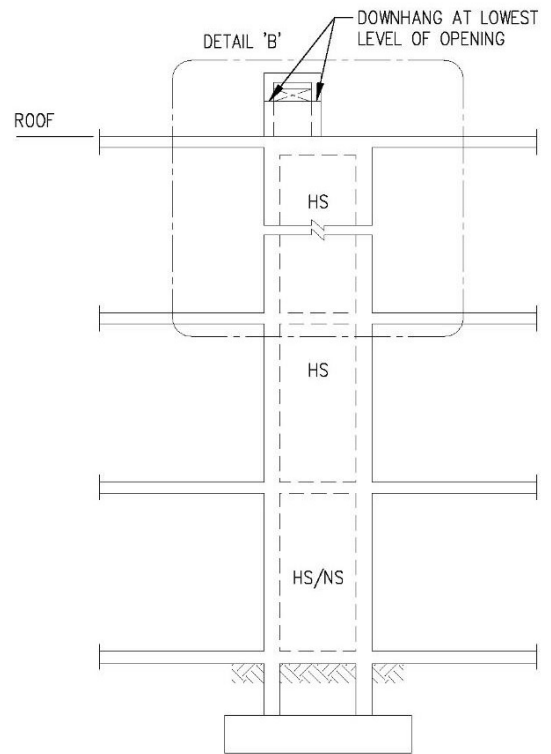

SECTION 2-2

FIGURE 2.4.7c (iii) RISER ADJACENT TO HS WITH PROJECTION ABOVE MAIN ROOF LEVEL

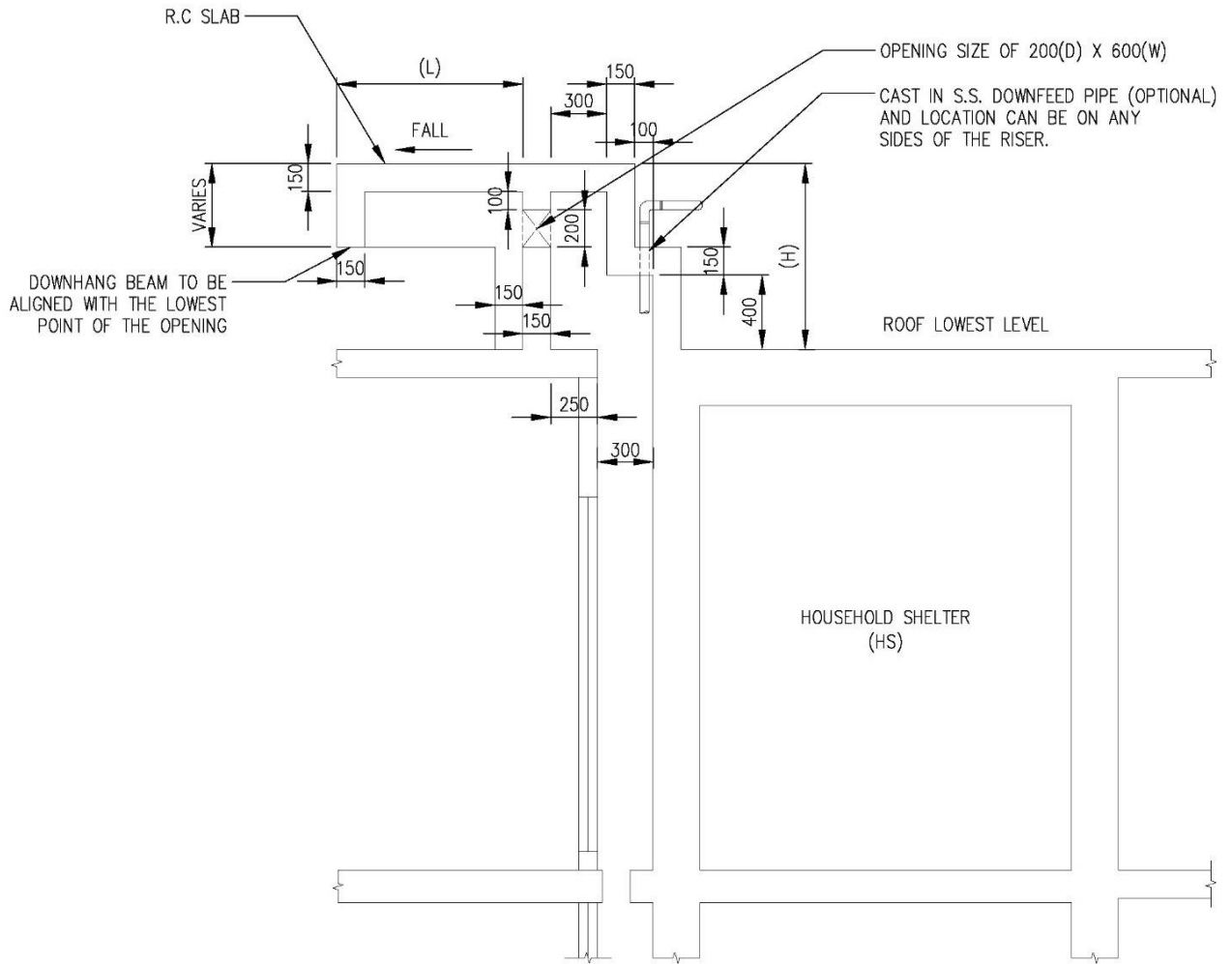

DETAIL 'A'

NOTE:

1. THE HEIGHT OF THE RISER PROJECTED ABOVE MAIN ROOF LEVEL SHALL BE AT LEAST 500mm.
2. THE RATIO OF 1:1 BETWEEN THE LENGTH OF THE PROJECTION SLAB (L) AND THE HEIGHT OF THE RISER (H) ABOVE THE MAIN ROOF LEVEL SHALL BE MAINTAINED.
3. THE WALL AND SLAB THICKNESS OF RISER PROJECTED ABOVE MAIN ROOF LEVEL SHALL HAVE A MINIMUM THICKNESS OF 150mm.
4. THE DOWNHANG BEAM FROM THE PROTECTIVE SLAB SHALL BE ALIGNED WITH THE LOWEST POINT OF THE OPENING SHOWN.

FIGURE 2.4.7c (iv) RISER ADJACENT TO HS WITH PROJECTION ABOVE MAIN ROOF LEVEL

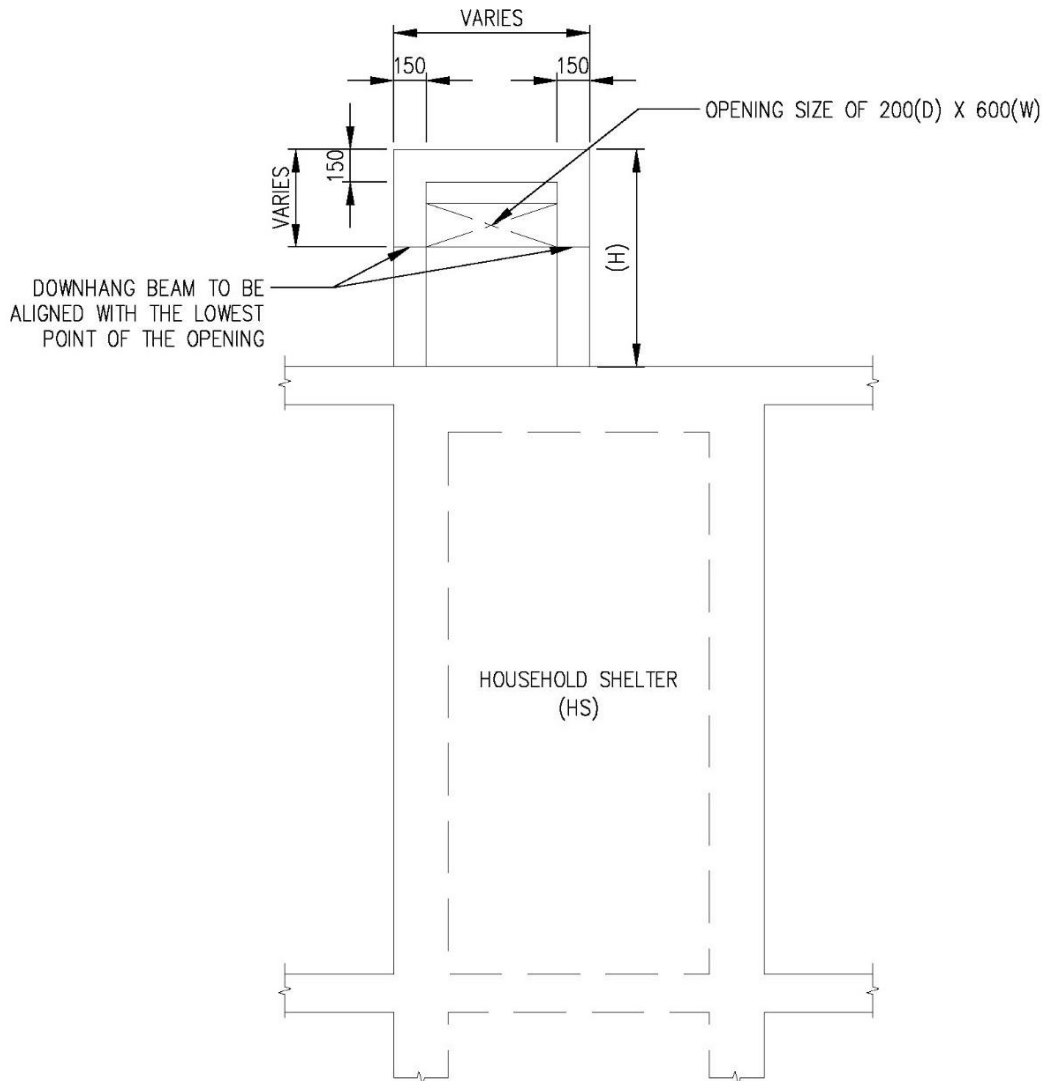

DETAIL 'B'

NOTE:

1. THE HEIGHT OF THE RISER PROJECTED ABOVE MAIN ROOF LEVEL SHALL BE AT LEAST 500mm.
2. THE RATIO OF 1:1 BETWEEN THE LENGTH OF THE PROJECTION SLAB (L) AND THE HEIGHT OF THE RISER (H) ABOVE THE MAIN ROOF LEVEL SHALL BE MAINTAINED.
3. THE WALL AND SLAB THICKNESS OF RISER PROJECTED ABOVE MAIN ROOF LEVEL SHALL HAVE A MINIMUM THICKNESS OF 150mm.
4. THE DOWNHANG BEAM FROM THE PROTECTIVE SLAB SHALL BE ALIGNED WITH THE LOWEST POINT OF THE OPENING SHOWN.

FIGURE 2.4.7c (v) RISER ADJACENT TO HS WITH PROJECTION ABOVE MAIN ROOF LEVEL

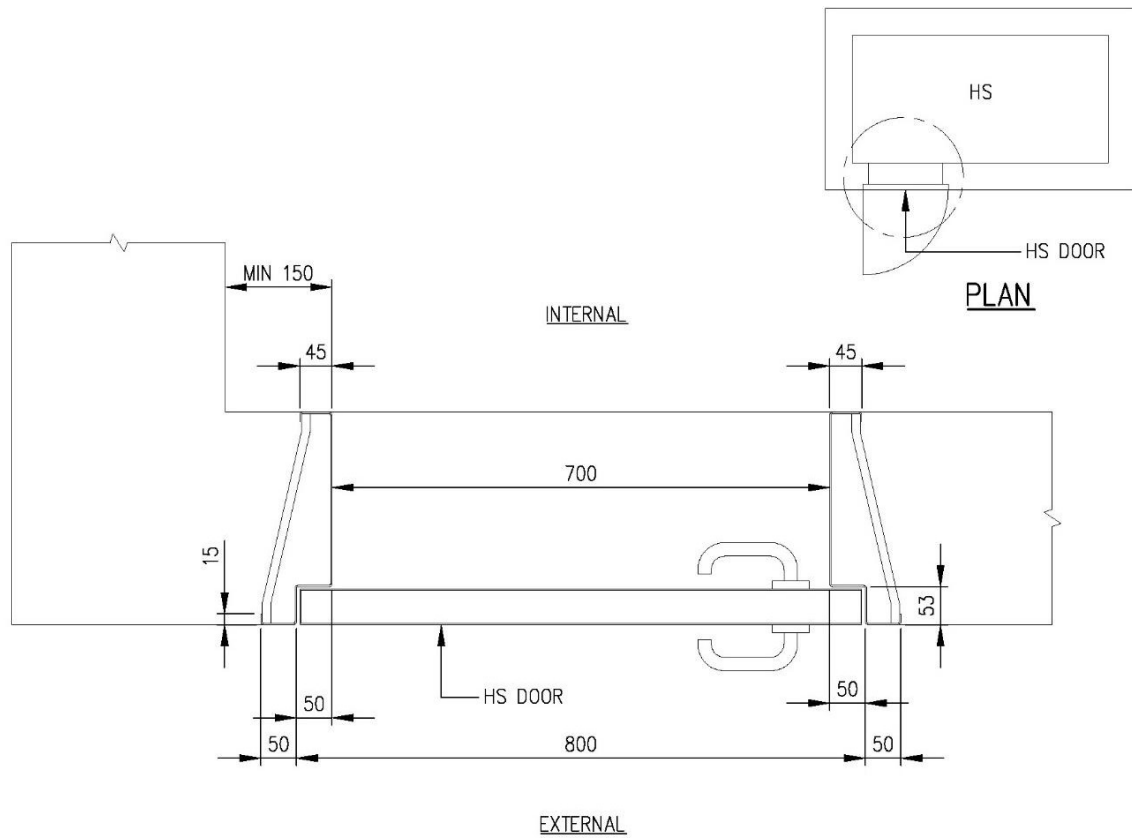

FIGURE 2.5.1(a) HS DOOR FRAME WITH SINGLE DOOR REBATE

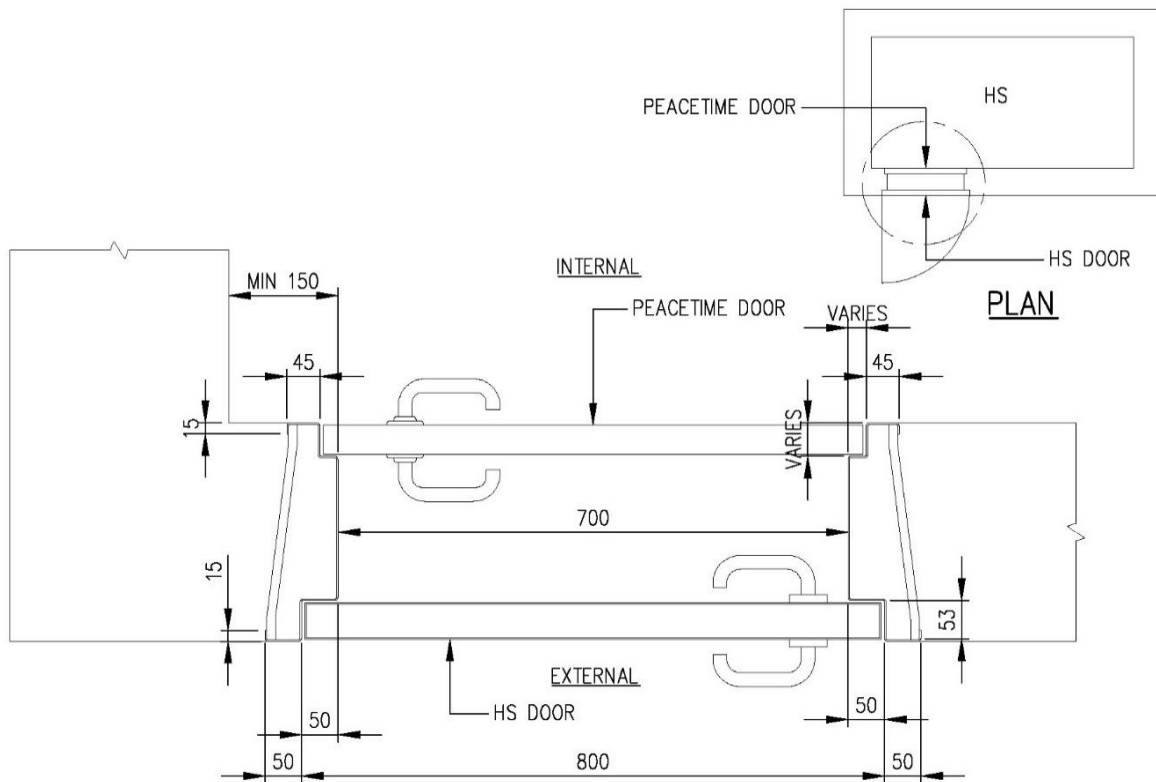

FIGURE 2.5.1(b) HS DOOR FRAME WITH DOUBLE DOOR REBATES

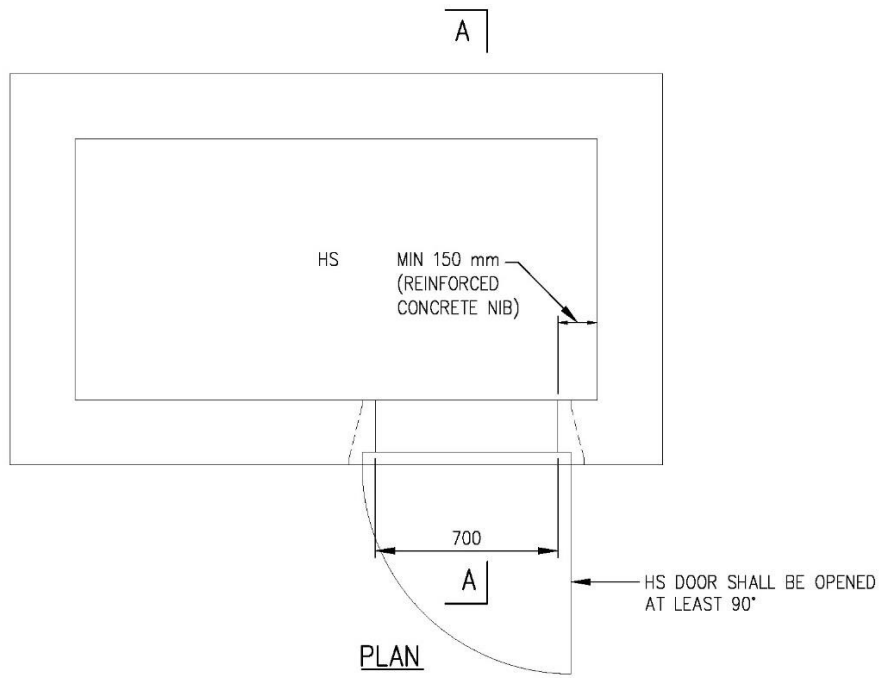

FIGURE 2.5.2(a) CONCRETE WALL SEGMENT AT HS DOOR

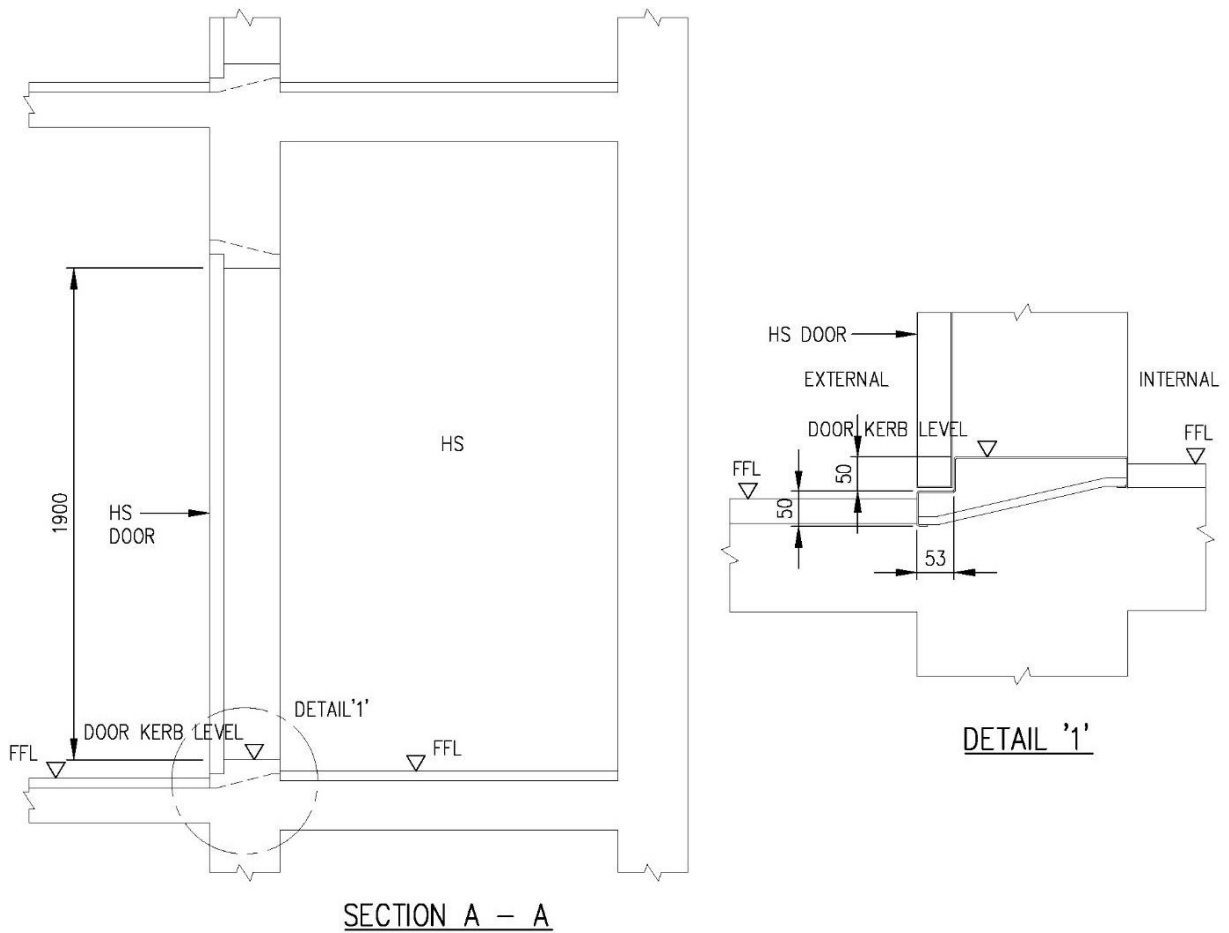

FIGURE 2.5.2(e) HS DOOR KERB

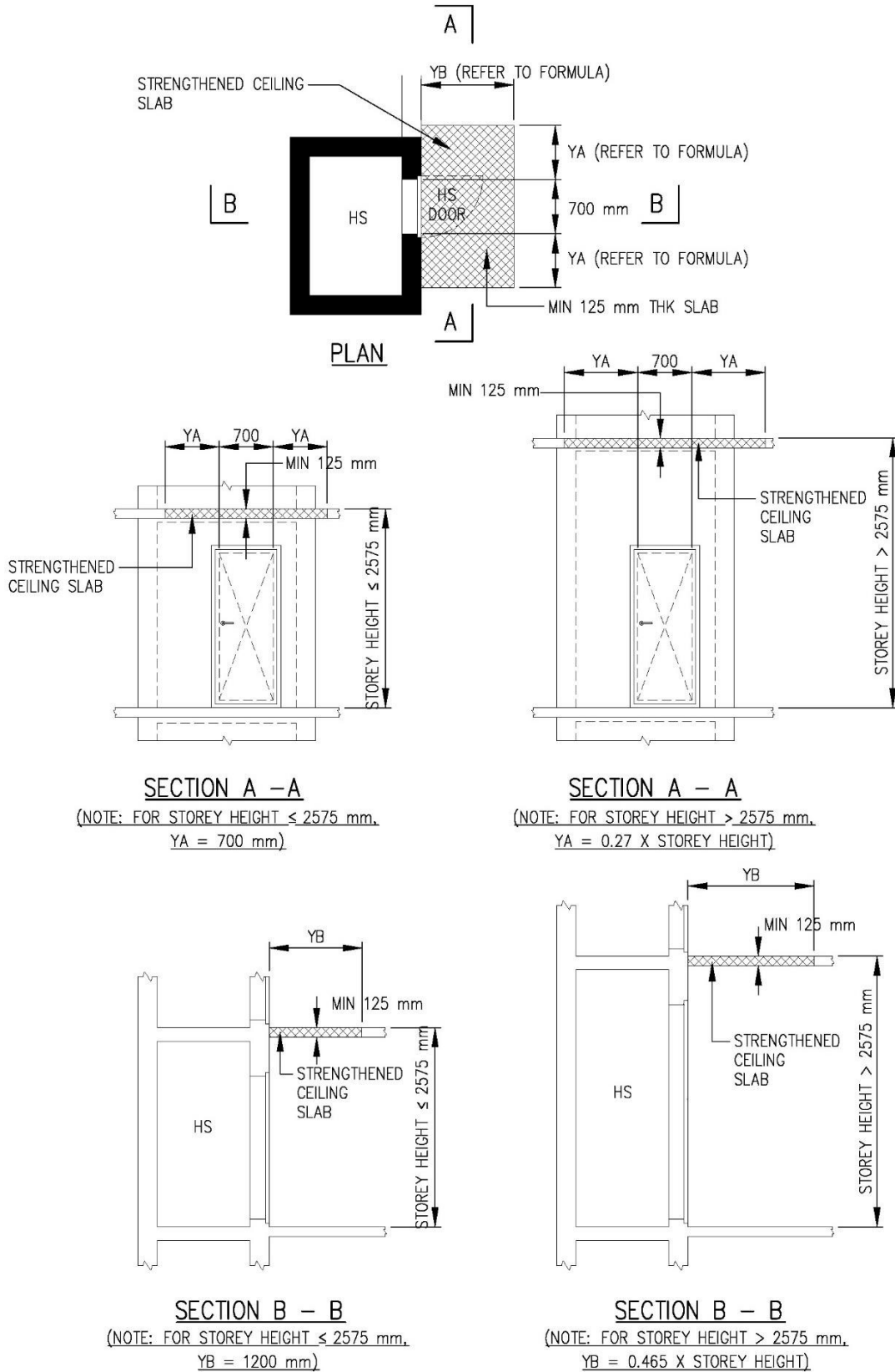

FIGURE 2.5.3 REQUIREMENTS FOR STRENGTHENED CEILING SLAB IN FRONT OF HS DOOR IN NON-LANDED DEVELOPMENT (APPLICABLE FOR HS IN NON-LANDED DEVELOPMENT)

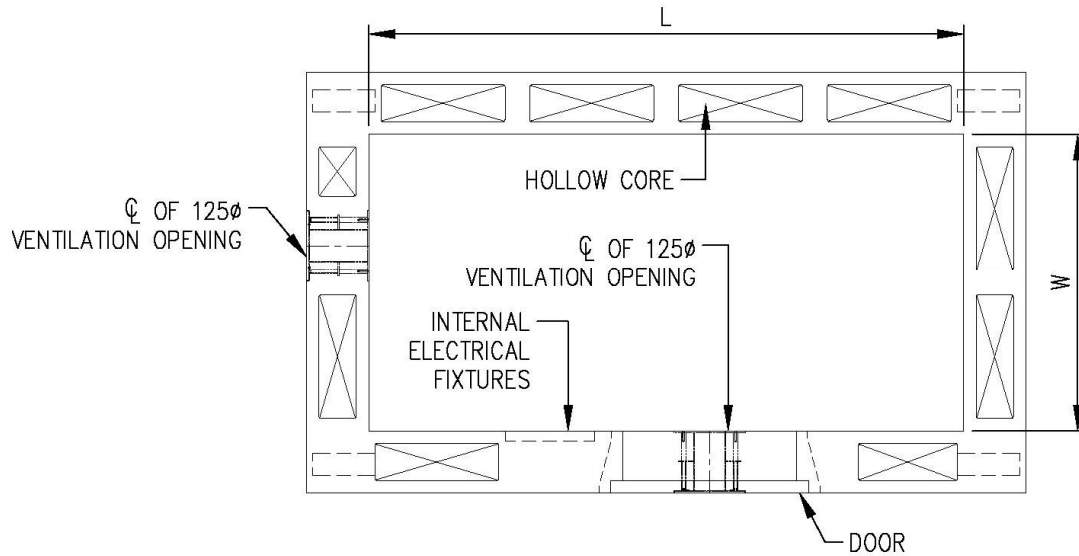

FIGURE 2.6.1(a) PRECAST HS WITH HS DOOR ON LONGER WALL AND ONE OF VENTILATION SLEEVES ABOVE THE DOOR

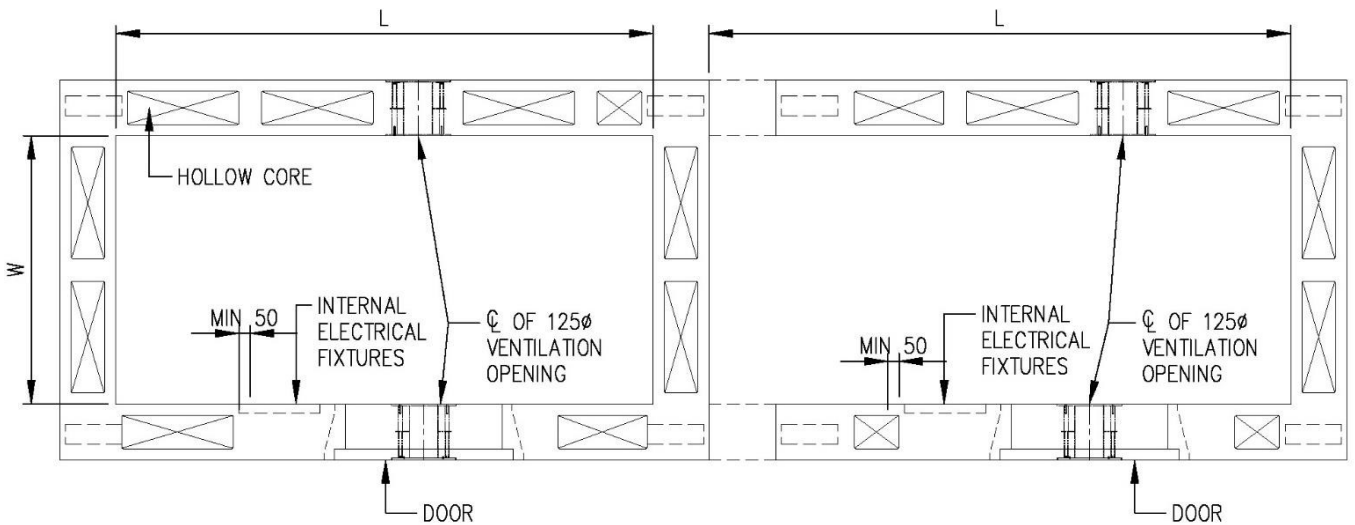

FIGURE 2.6.1(b) PRECAST HS AND C-SHAPED PRECAST HS CONNECTED AT THE SHORTER WALL AND WITH HS DOOR ON LONGER WALLS

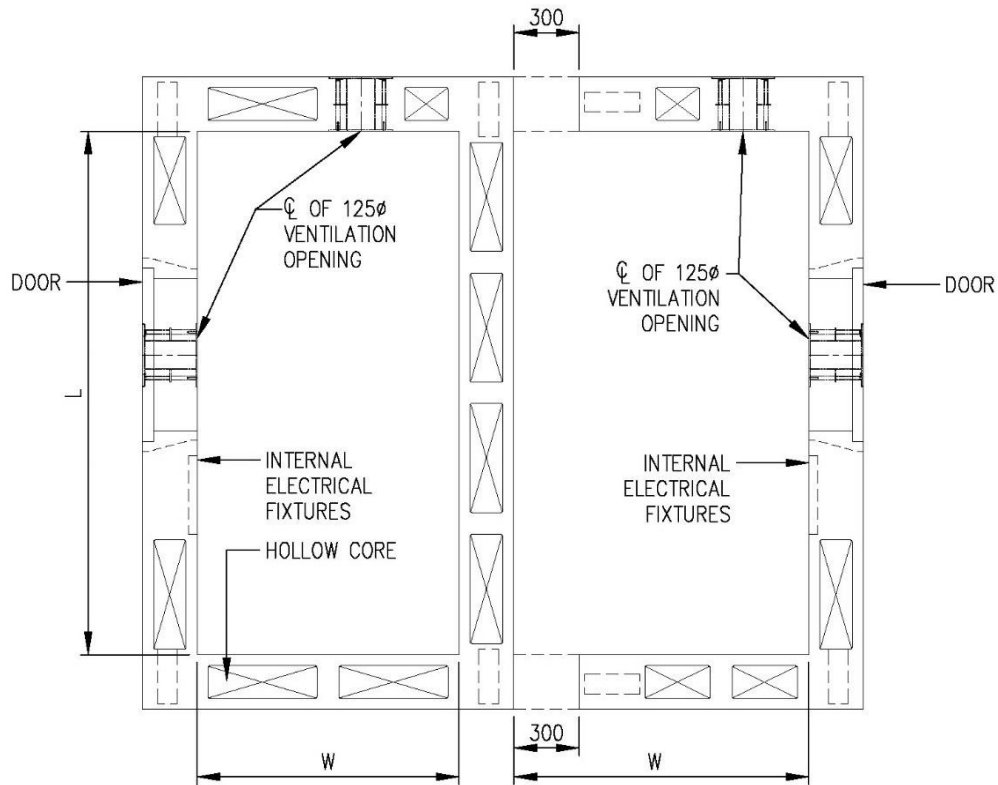

FIGURE 2.6.1(c) PRECAST HS AND C-SHAPED PRECAST HS CONNECTED AT THE LONGER WALL AND WITH HS DOOR ON LONGER WALLS

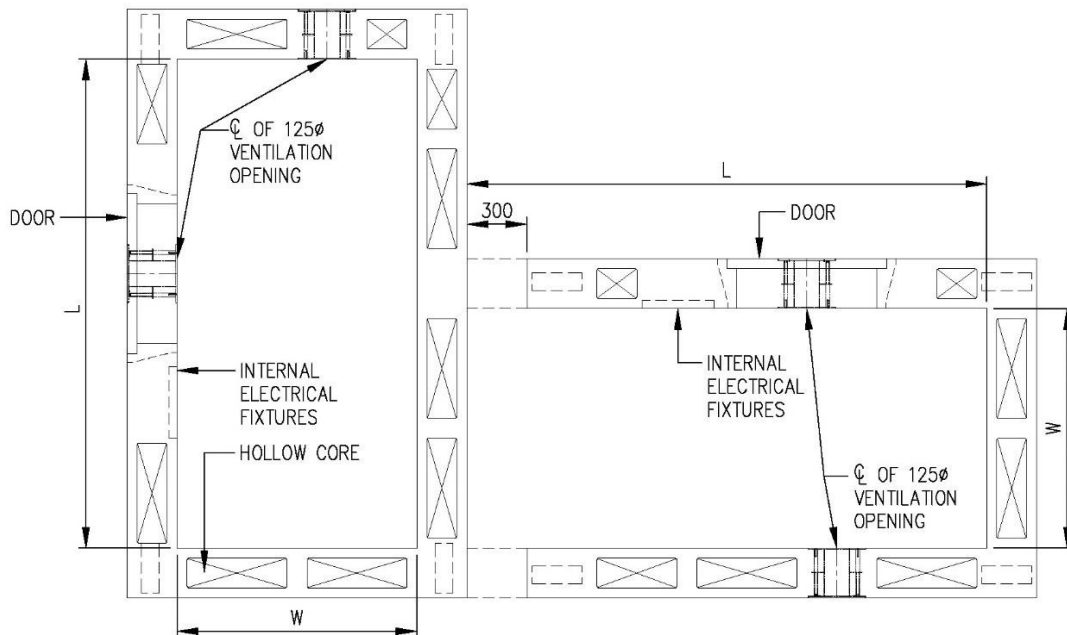

FIGURE 2.6.1(d) PRECAST HS AND C-SHAPED PRECAST HS WITH CONNECTION BETWEEN LONGER AND SHORTER WALLS RESPECTIVELY AND WITH HS DOORS ON LONG WALL

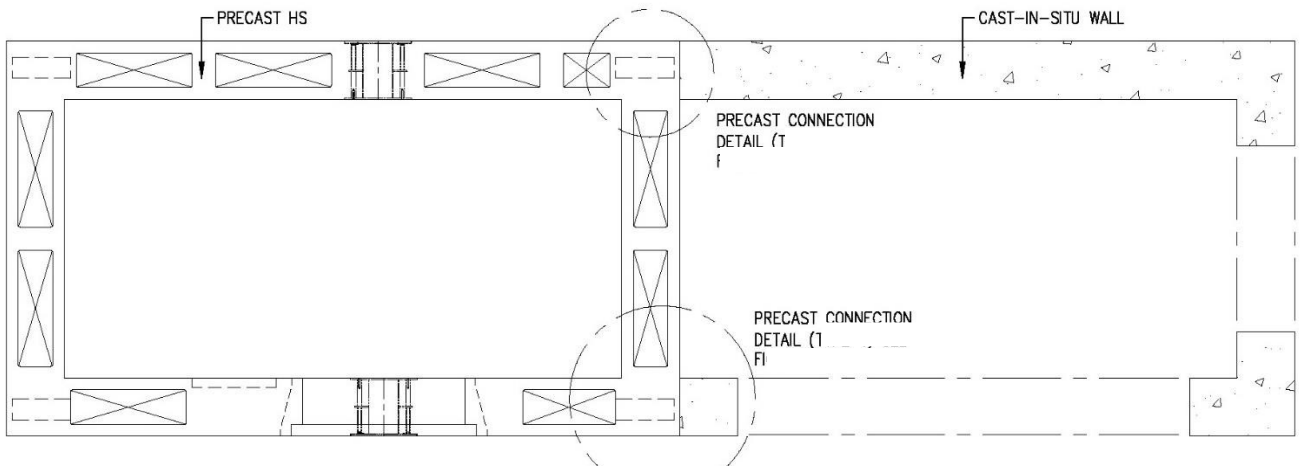

FIGURE 2.6.1(e) PRECAST HS ADJOINING CAST IN-SITU WALLS/COLUMNS

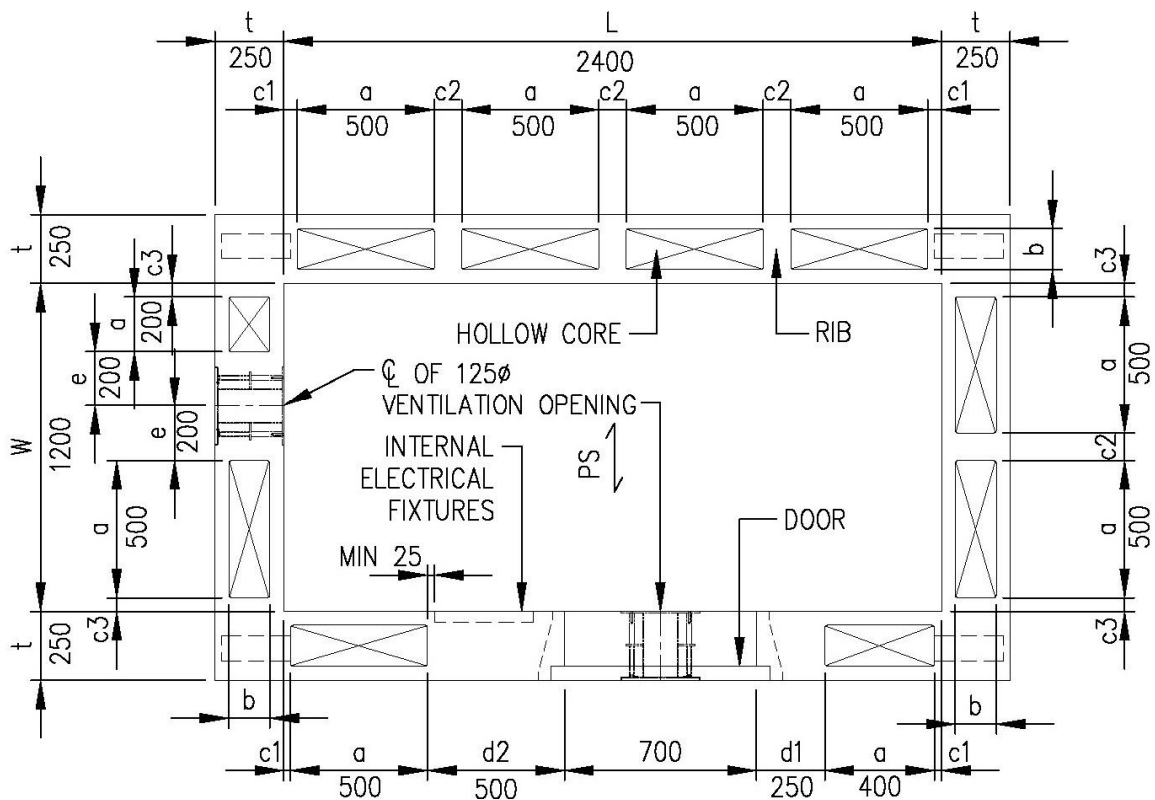

FIGURE 2.6.2(c) PRECAST HS DIMENSIONS

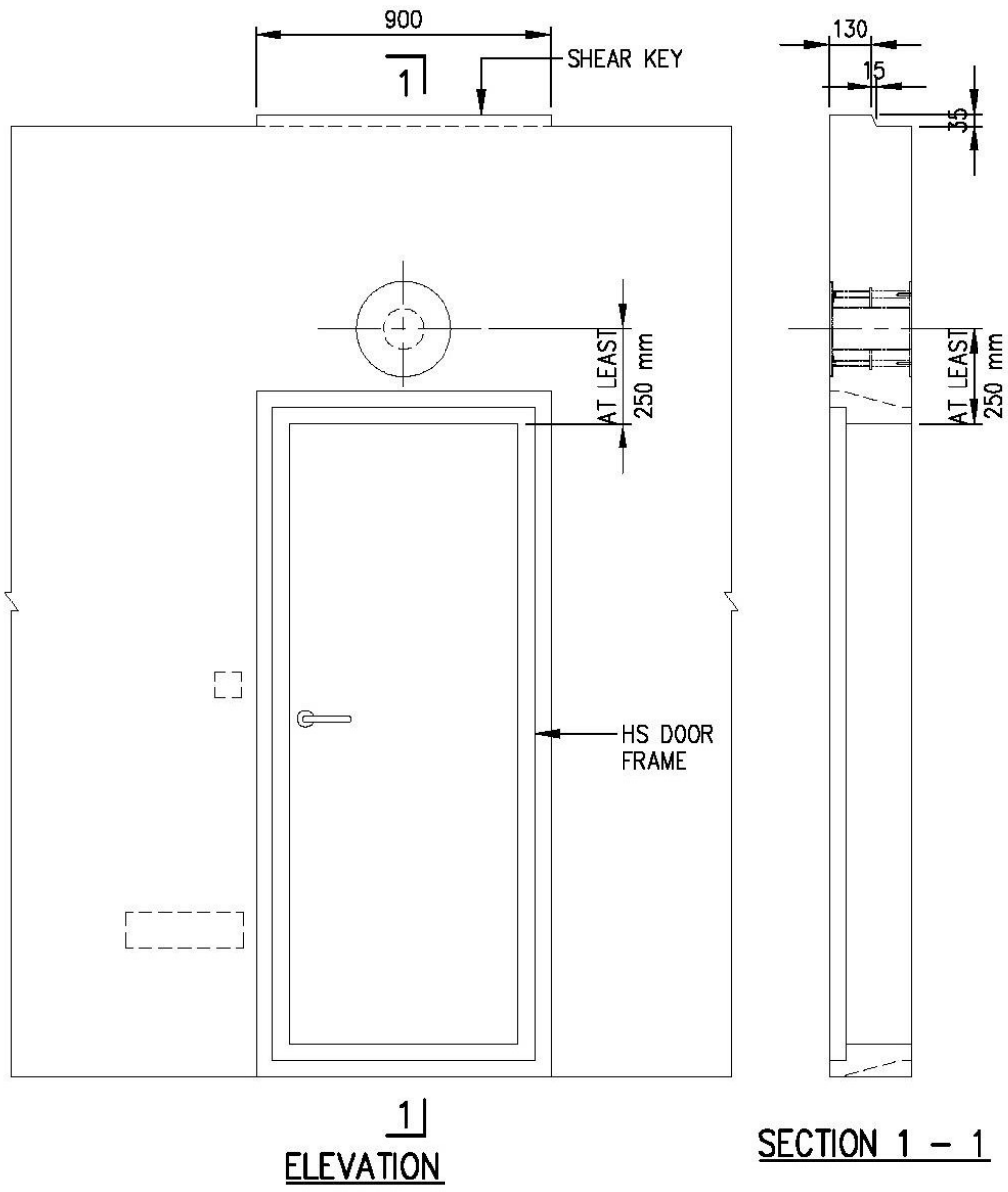
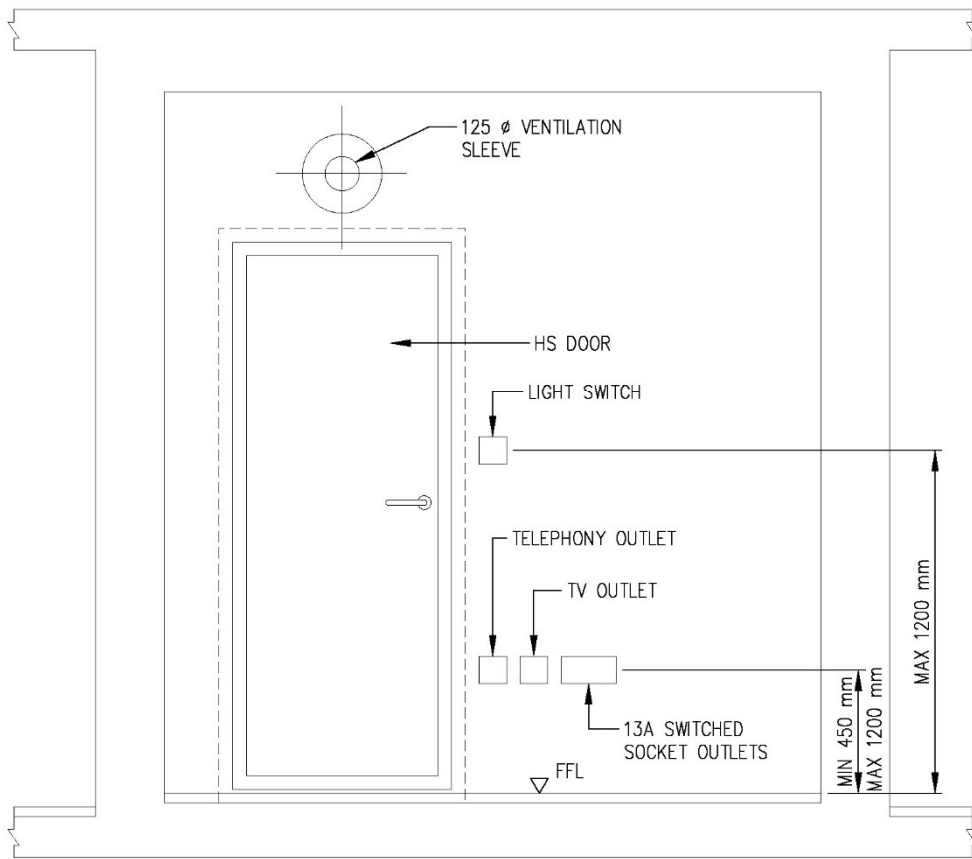
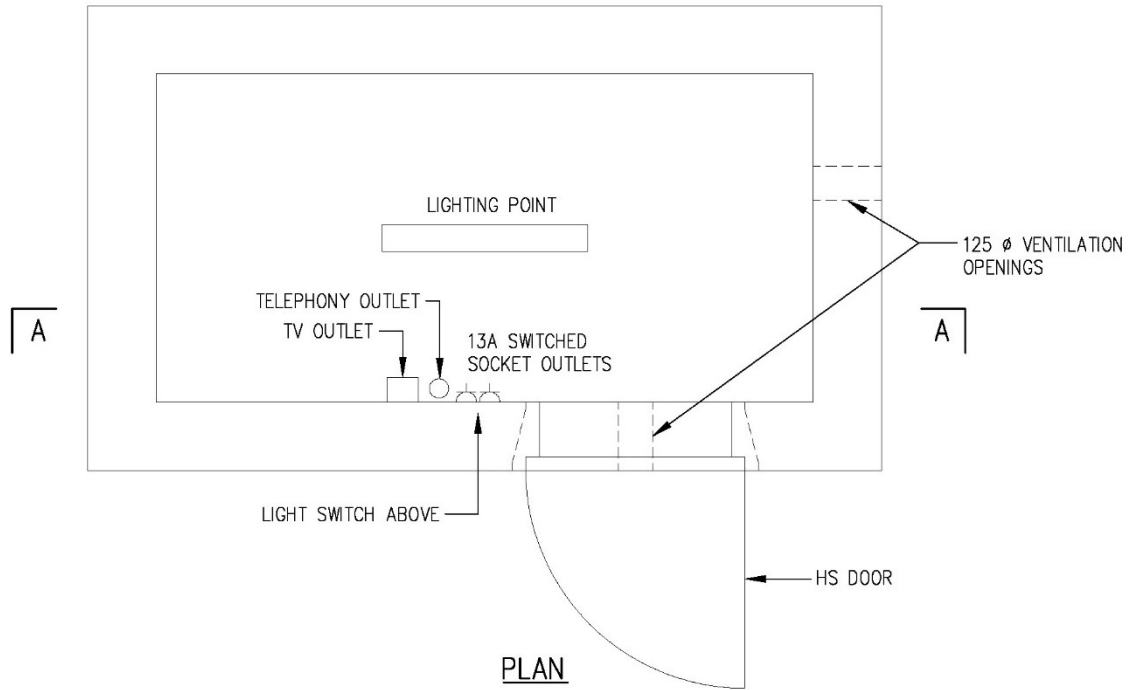

FIGURE 2.6.2(f) SHEAR KEY ON WALL ABOVE HS DOOR



SECTION A - A

FIGURE 2.7.1(c) FIXTURES IN HS

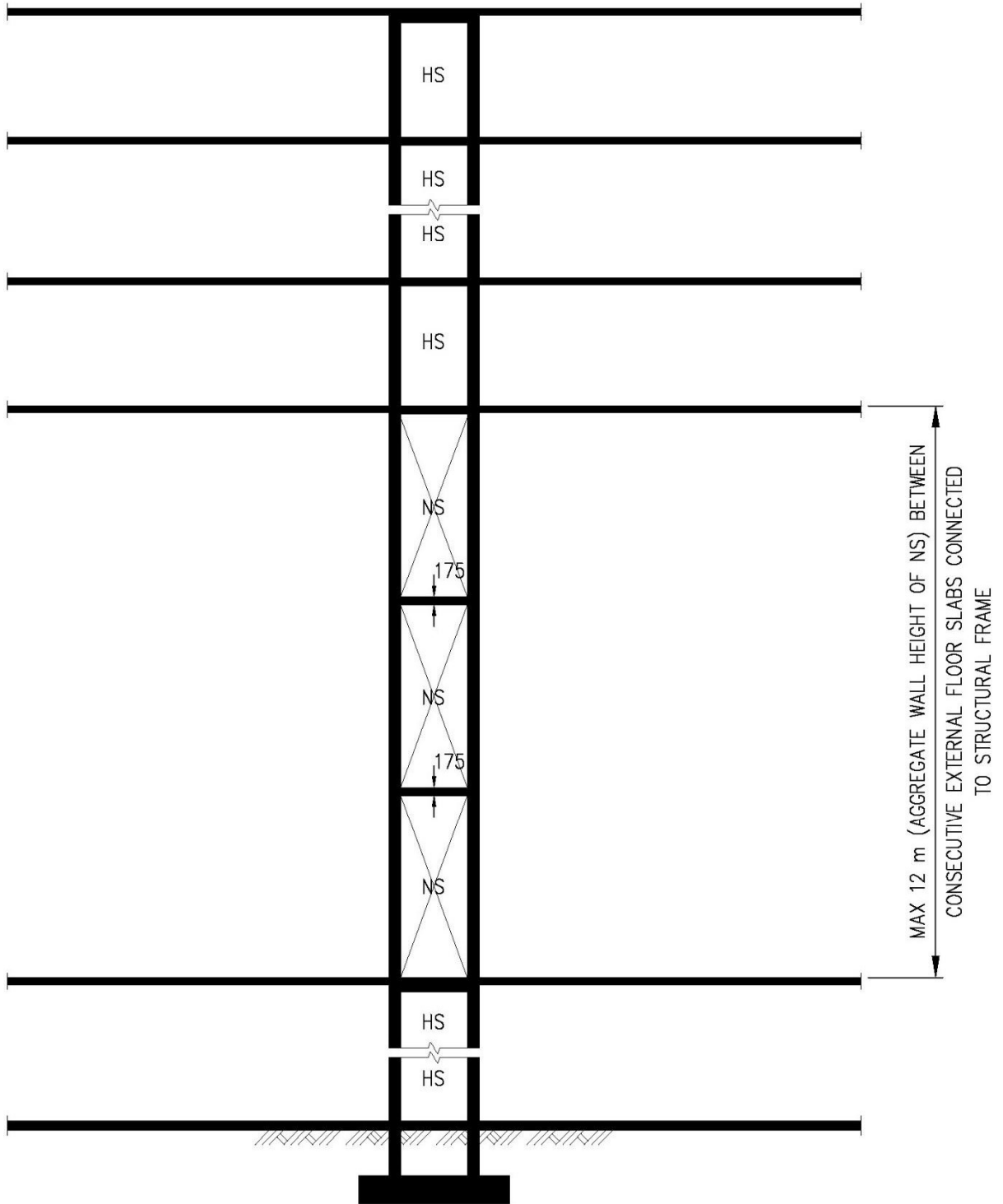

FIGURE 2.8.1(a) HS TOWER

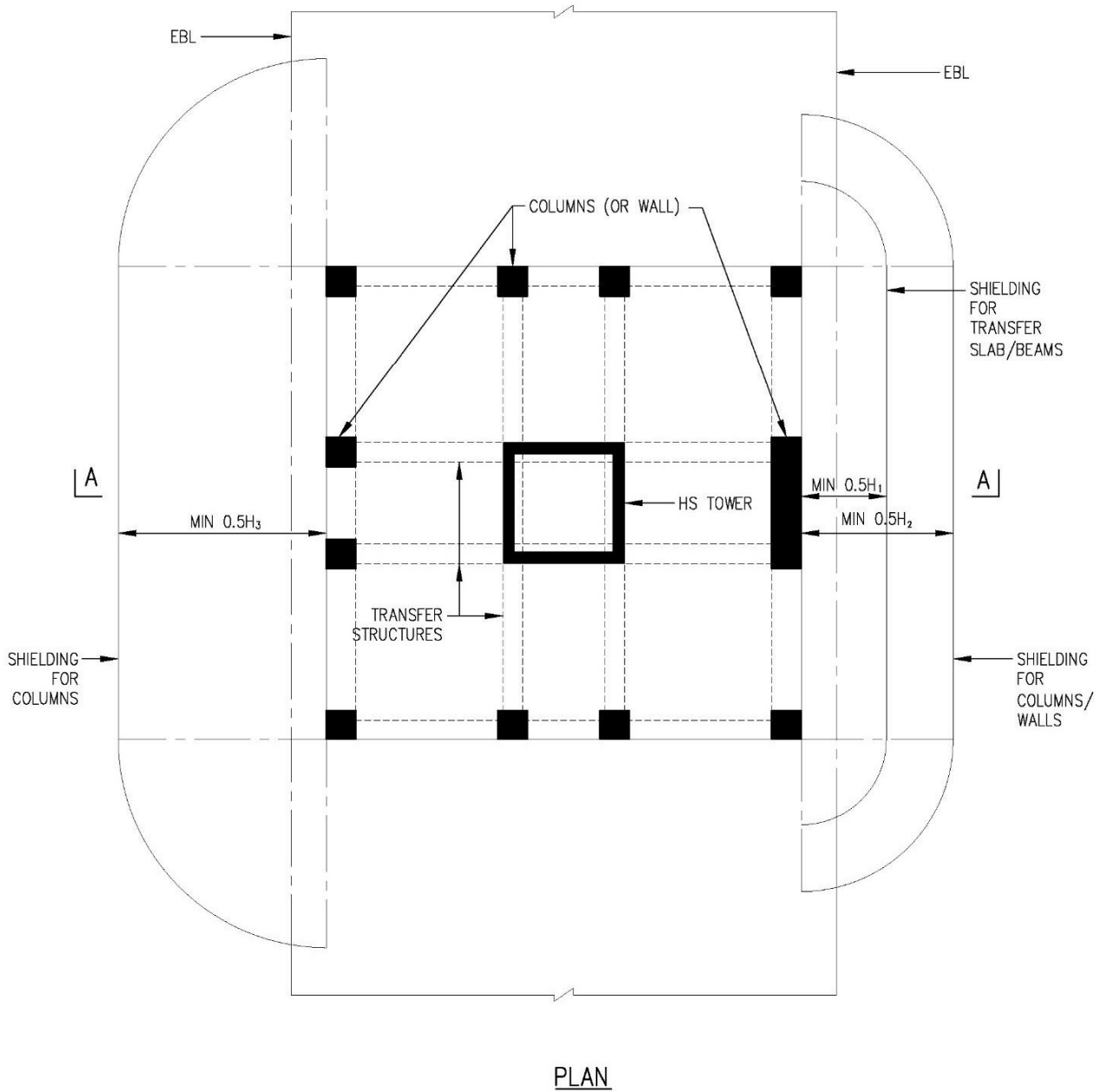
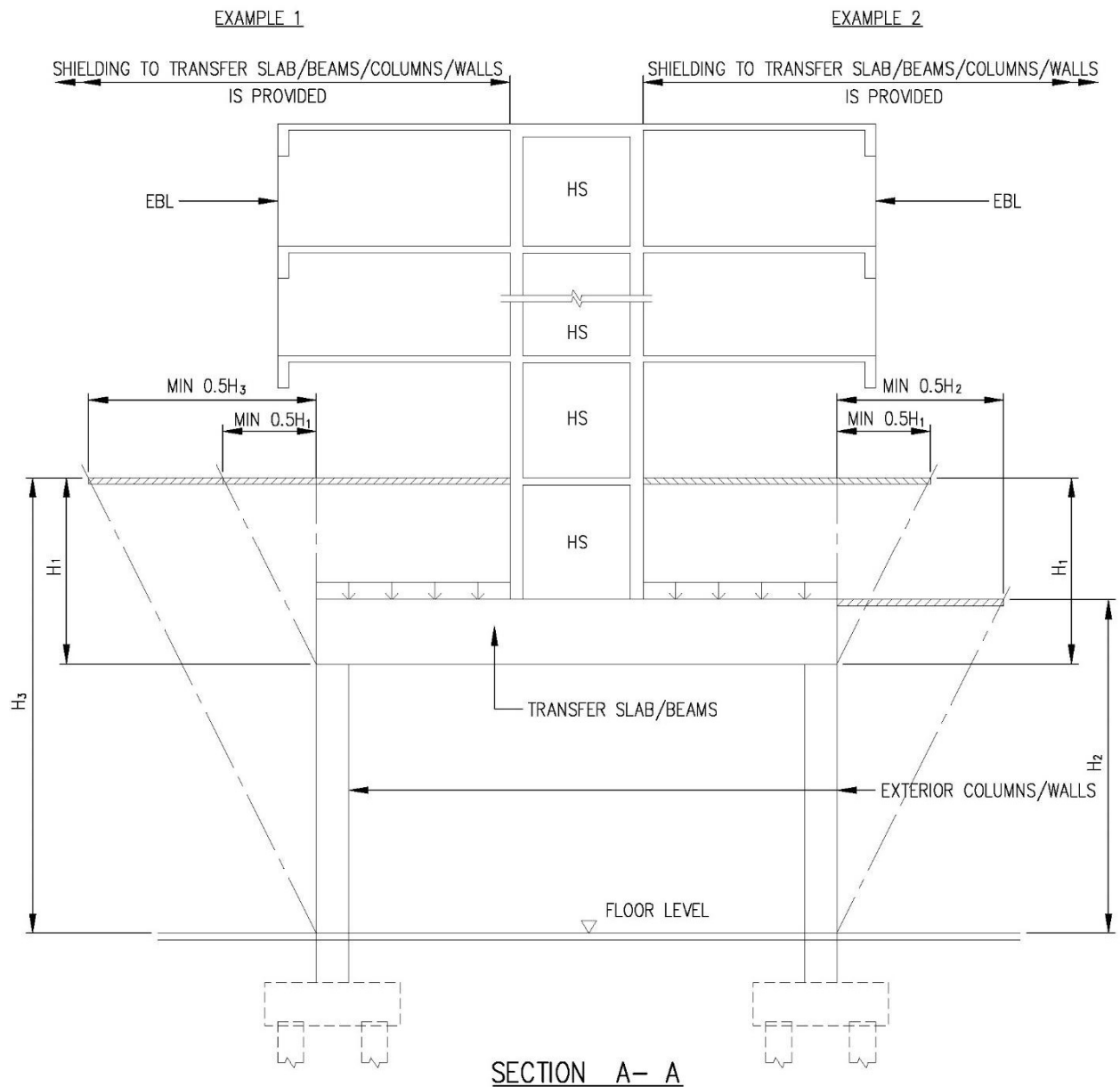
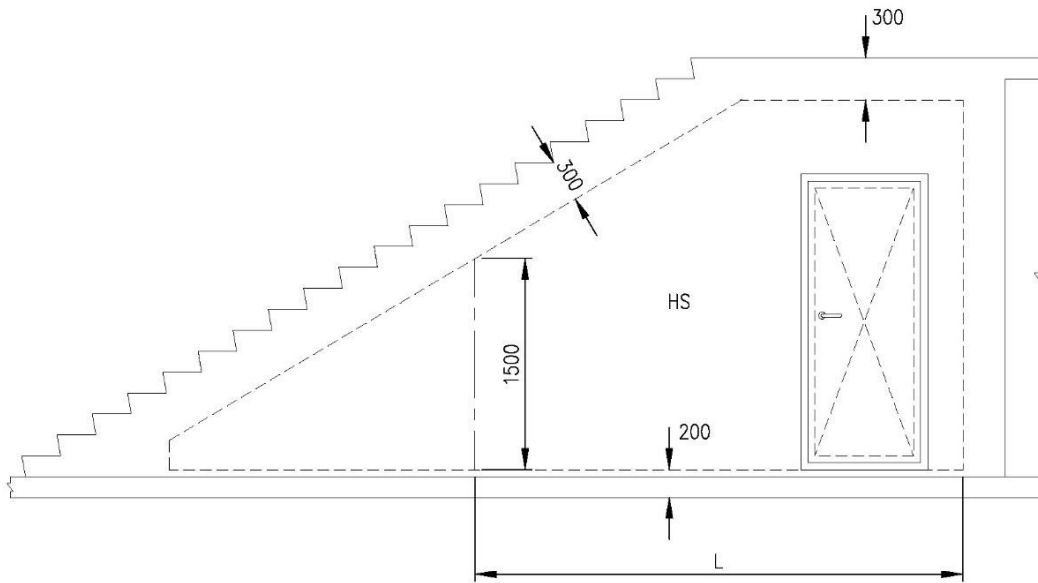

FIGURE 2.9.1(a) SHIELDING OF TRANSFER STRUCTURES SUPPORTING HS TOWER



**FIGURE 2.9.1(b) SHIELDING OF TRANSFER SLAB/BEAMS/
EXTERIOR COLUMNS/WALLS**



**SECTIONAL ELEVATION
(TYPE A)**

NOTE:

THE DIMENSION, L OF THE FLOOR SHALL BE USED FOR COMPUTING THE INTERNAL HS FLOOR AREA FOR THE PURPOSE OF TABLE 2.2.1(b) OR TABLE 2.2.1(c)

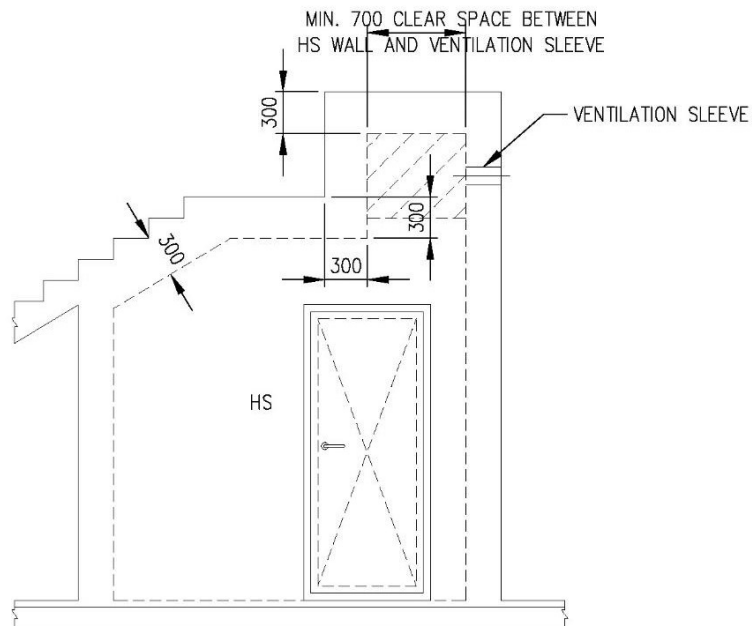

**SECTIONAL ELEVATION
(TYPE B)**

FIGURE 2.10 HS BENEATH AN INTERNAL STAIRCASE

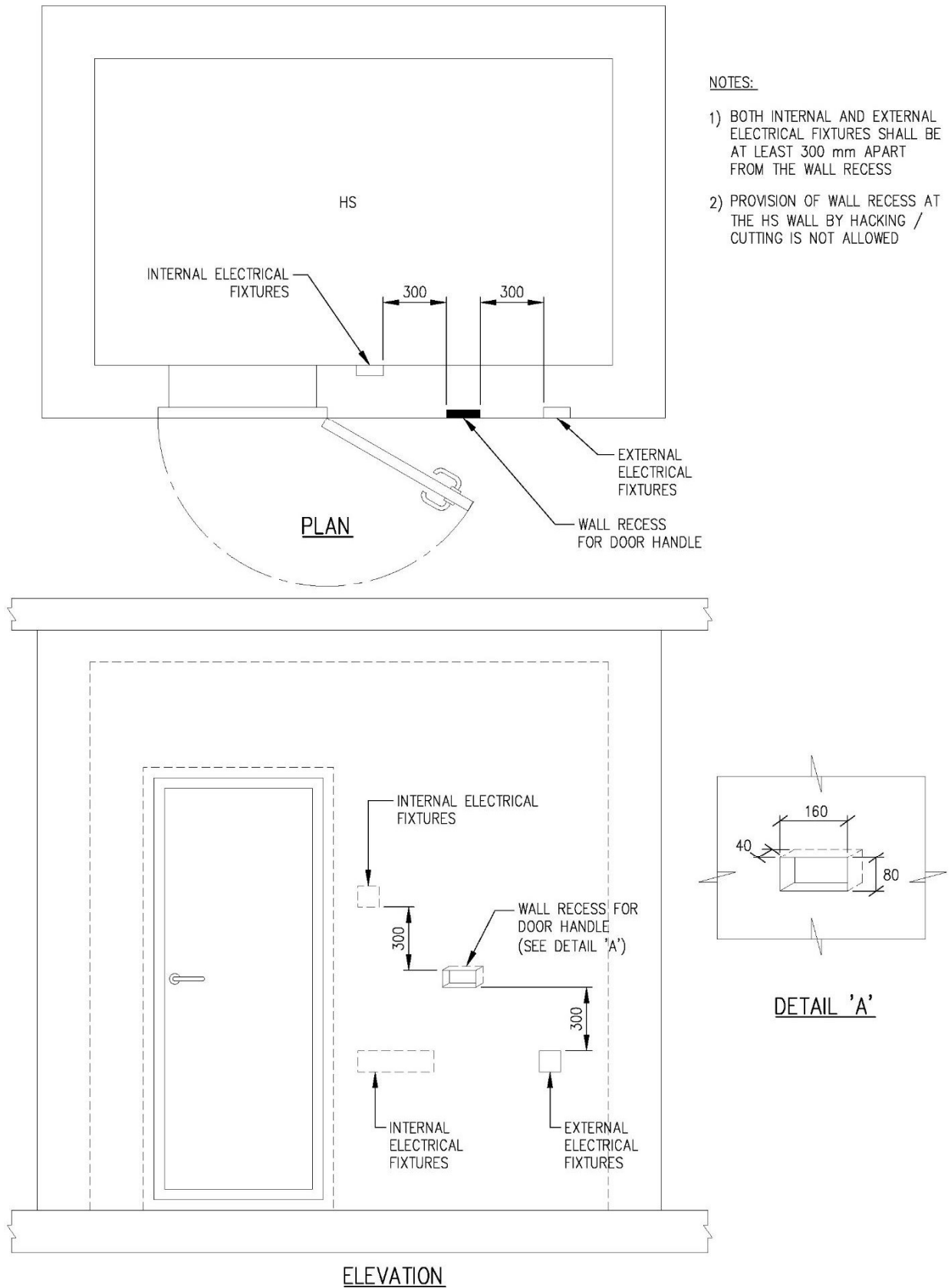

FIGURE 2.13 DETAILS OF WALL RECESS FOR HS DOOR HANDLE

CHAPTER 3: STRUCTURAL REQUIREMENTS

3.1 GENERAL

The structural design of the HS tower shall take into account both the vertical and lateral loads, where applicable.

The HS tower shall be designed for maximum degrees of redundancy in the structural system against weapon effects.

3.2 MATERIALS

3.2.1 Concrete

- a) The minimum concrete strength class shall be grade C25/30 for landed residential developments and C32/40 for non-landed residential developments.
- b) For residential development (non-landed) with GFA of 2000m² and above, precast volumetric household shelters shall be adopted and the concrete strength class shall be minimum C32/40.
- c) The use of pre-stressed concrete for the HS tower, and the transfer structure and its supporting walls and columns is not permitted.

3.2.2 Steel Reinforcement

The steel reinforcement of concrete shall be welded steel fabric mesh and hot rolled steel bars. The minimum yield strength for the main reinforcements and shear links in the structural elements forming the HS or NS shall be 500 N/mm².

3.3 ANALYSIS

3.3.1 General

The vertical continuity of HS and NS walls, where applicable, to the foundation shall comply with clause 2.4.2.

3.3.2 Beam Supported by HS wall

The beam that is supported by HS wall shall be designed and detailed as simply supported on the HS wall or cantilever from the HS wall.

3.3.3 Shielded NS walls and/or NS columns

No additional design checks on HS tower is required if its supporting NS elements, wall(s), column(s) or any of its combination, are shielded. These structural elements are deemed adequately shielded if reinforced concrete slab or other equivalent structural forms

provided above them is extended beyond their edges by a minimum length of $0.5H$, where H is the aggregate wall height of NS (See FIGURE 3.3.3).

3.3.4 Unshielded NS Wall(s) and/or NS Columns

The following requirements are to be complied with if the design adopts:

(a) Unshielded NS Wall(s)

The minimum thickness of each NS wall shall be 300 mm. The HS tower shall be designed against the most severe effects as the result of the removal of a portion of the NS wall equivalent to an opening of 1500 mm diameter on the NS wall at its most critical location (See FIGURE 3.3.4(a)).

(b) Unshielded NS Column(s)

The minimum size (either its diameter or the shorter dimension) of NS column shall be 500 mm. The HS tower shall be designed against the most severe effects as the result of the removal of any one NS column (See FIGURE 3.3.4(b)).

(c) Combination of Unshielded NS Wall(s) and NS Column(s)

The minimum thickness of each NS wall and minimum size (either its diameter or the shorter dimension) of NS column shall be 300 mm and 500 mm respectively. The HS tower shall be designed against the most severe effects as the result of the following (See FIGURE 3.3.4(c)):

- (i) Removal of a portion of the NS wall equivalent to an opening of 1500 mm diameter on the NS wall at its most critical location and
- (ii) Removal of any one NS column at a time.

The above removal of wall or column shall be considered one at a time.

(d) The following criteria are to be used when performing design checks for Clause 3.3.4(a), 3.3.4(b) or 3.3.4(c):

- (i) The design loads shall be based on the load combination and values of partial safety factors for actions (γ_f) in accordance with Table 3.3.4(d).
- (ii) The design strength for a given material is derived from the characteristic strength divided by the partial safety factor for strength of material (γ_m), which shall be 1.2 for concrete and 1.0 for reinforcement.

3.3.5 Transfer Structure Supporting HS Tower

3.3.5.1 Design against Collapse Load

The design loads for the transfer structure shall include a collapse load of 20kN/m^2 acting on transfer slab/beam. An additional load combination in the design of transfer structure supporting the HS tower, incorporating the collapse load, shall be considered with partial safety factors for actions (γ_f) given in Table 3.3.5.1. Only one transfer of HS loads from each tower by the transfer structure to its supporting columns and/ or walls is allowed. Multiple transfers of HS load from the same HS tower is not allowed. See FIGURE 2.9.1(a) and FIGURE 2.9.1(b).

3.3.5.2 Shielded Transfer Structure

No additional design checks on transfer structure are required, besides the requirement in Clause 3.3.5.1, if the transfer structures are shielded by RC slab or other equivalent structural forms. The transfer structure is deemed adequately shielded if Clause 3.3.5.2(a) and 3.3.5.2(b) are complied with:

(a) Shielding of Transfer slab/beams

The transfer slab/beams are deemed to be shielded if RC shielding slab or other equivalent structural forms is provided directly above the transfer slab/beams and is extended beyond their external edges by a minimum length of $0.5H_1$, where H_1 is the vertical distance between the top level of the RC shielding slab and the soffit of transfer slab/beams (See FIGURE 3.3.5.2(a)).

(b) Shielding of Exterior Columns

The transfer columns are deemed to be shielded if RC shielding slab or other equivalent structural forms is provided above the exterior columns and is extended beyond their exterior edges by a minimum length of $0.5H_2$ or $0.5H_3$, where H_2 and H_3 are the vertical distances between the top level of the RC shielding slab and the base of the exterior columns (See FIGURE 3.3.5.2(a)).

3.3.5.3 Unshielded Transfer Structure

Besides the requirement in Clause 3.3.5.1, additional design checks on unshielded transfer structure (See FIGURE 3.3.5.3) shall be carried out in accordance with the following requirements:

(a) Unshielded Transfer Slab/Beams

The transfer structure shall be designed against the most severe effects as the result of the removal of a portion of the transfer slab/beam equivalent to an opening of 1500 mm diameter on the transfer slab/beams at its most critical location (See FIGURE 3.3.5.3a (i) and FIGURE 3.3.5.3a (ii)).

(b) Unshielded Exterior Columns and Walls

The minimum size (either its diameter or shorter dimension) of the exterior columns shall be 500 mm and the minimum thickness of the wall shall be 300mm. The transfer structure shall be designed against the most severe effects as the result of the removal of any one exterior column at a time or the removal of a portion of the exterior wall equivalent to an opening of 1500 mm diameter on the transfer wall at its most critical location. Alternative path for load transfer shall be designed for such cases (See FIGURE 3.3.5.3b (i) and FIGURE 3.3.5.3b (ii)).

(c) The following are the criteria to be used when performing design checks for Clause 3.3.5.3(a) and 3.3.5.3(b):

- (i) The design loads including collapse load, shall be based on the load combination and values of partial safety factors for loads (γ_f) in accordance with Table 3.3.5.1.
- (ii) The design strength for a given material is derived from the characteristic strength divided by the partial safety factor for strength of material (γ_m), which shall be 1.2 for concrete and 1.0 for reinforcement.

3.4 MEMBER DIMENSIONS AND REINFORCEMENT REQUIREMENTS

3.4.1 Member Dimensions

The minimum member size of HS and NS shall be as stipulated in Chapter 2 – Architectural Design.

3.4.2 Reinforcement Requirements

All diameters of reinforcement specified hereinafter shall refer to minimum bar diameters. All spacing of reinforcement specified hereinafter shall refer to maximum spacing of reinforcement in both directions.

3.4.2.1 Wall Reinforcements of HS and NS

- (a) Minimum Reinforcement in HS walls in landed development – refer to TABLE 3.4.2.1(a).
- (b) Minimum Reinforcement in HS or NS walls in non-landed development – refer to TABLE 3.4.2.1(b).
- (c) Reinforcements at both faces of the internal common wall shall be H 10-100 c/c in both directions. The shear links shall be H8-600 c/c in both directions.
- (d) Reinforcements at each sides of the blast door frame and its stiffeners shall be 2 H13.

3.4.2.2 Slab Reinforcements of HS and NS

Top and bottom reinforcements of the slab shall be H 10-100 c/c in both directions. The shear links shall be H8-600 c/c in both directions.

3.4.2.3 Ceiling Slab Immediately Outside the HS

- (a) The ceiling slab immediately outside the HS wall with HS door shall be constructed of reinforced concrete. Two layers of reinforcement bars (top and bottom) of H 10-100 c/c in both directions shall be provided for the ceiling slab with minimum 125mm thick.
- (b) The reinforcements of every floor slab immediately outside HS tower walls shall be structurally connected to HS tower.

3.4.2.4 HS Slab Which Is Integrated With Pile-Cap/Footing

For HS slab integrated with the pile-cap or footing of more than 500 mm thick, shear links is not required. The maximum spacing of main reinforcement shall be 200 mm c/c.

3.4.2.5 Reinforcement Bar Details of Precast Shielding Wall for HS Wall

The shielding wall for the HS wall could be built of brick/ block wall and precast reinforced concrete wall ((See FIGURE 2.4.5(a) to (g))

- (a) The brick/ block wall shall be tied to the reinforcement concrete walls or columns by a wall tie system to ensure lateral stability
- (b) The precast reinforced concrete wall shall comply with the following requirements:
 - (i) The steel welded mesh of minimum H10 spaced at 200mm vertically and horizontally shall be used for both faces of shielding precast reinforced concrete wall.
 - (ii) The shear links (C-shaped) shall be H8 spaced at 600mm vertically and horizontally with at least 75mm bent at two ends around the outermost reinforcement bar.

3.5 **DETAILING OF HS TOWER**

3.5.1 **General**

The HS tower is to be detailed to allow for the installation of services and fixtures in HS and to resist spalling of the internal face of HS walls, soffit of ceiling slabs and/or finishes on HS floor slab.

3.5.2 Lap and Anchorage Length

Requirements for lap and anchorage length of reinforcement bars are as follows:

- (a) Full lap and anchorage length of reinforcements in HS and NS walls and slabs shall be provided. The lap length shall take into account good or poor bond condition, steel bar diameter, shape of steel bar, concrete cover, steel strength and location where reinforcement bar laps and confinement of transverse bars.
- (b) Minimum tension lap and anchorage length of reinforcement bars for concrete grades C25/30 and C32/40 with good bond condition shall be as shown in TABLE 3.5.2(a) and TABLE 3.5.2(b) respectively. Longer tension lap and anchorage length shall be provided if they are required to meet poor bond condition and/or the structural load and safety requirements.
- (c) Welding of reinforcement bars to attain tension anchorage length or tension lapped length is not permitted.
- (d) Bundled bars are not permitted.

3.5.3 Concrete Cover

The minimum and maximum concrete covers to the main reinforcement shall be 25mm and 40 mm respectively.

3.5.4 Cast-In-Situ Elements

Cast-In-Situ HS elements shall comply with the dimensions and detailed requirements as shown in the following figures:

- FIGURE 3.5.4 (a) - Plan of HS
- FIGURE 3.5.4 (b) - Sectional details of HS slabs/walls
- FIGURE 3.5.4 (c) - Sectional details of HS slabs/walls
- FIGURE 3.5.4 (d) - Plan of two HS with an internal common wall
- FIGURE 3.5.4 (e) - Sectional details of two HS with an internal common wall
- FIGURE 3.5.4 (f) - Details of HS wall reinforcement bar near HS door
- FIGURE 3.5.4 (g) - Typical details of embedded conduit in HS wall
- FIGURE 3.5.4 (h) - Typical details of trimmer bars for ventilation sleeve
- FIGURE 3.5.4 (i) - Typical details of trimmer bars for wall recess
- FIGURE 3.5.4 (j) - Details of shear links in HS slabs/walls

3.5.5 Precast HS Door Frame Panel

- FIGURE 3.5.5 (a) - Plan of HS with pre-cast HS door frame panel (Type 1)
- FIGURE 3.5.5 (b) - Details and Sections of pre-cast HS door frame panel with ventilation sleeve above it (Type 1)

- FIGURE 3.5.5 (c) - Sections of pre-cast HS door frame panel with ventilation sleeve above it (Type 1)
- FIGURE 3.5.5 (d) - Details and Sections of pre-cast HS door frame panel with ventilation sleeve at its side (Type 1)
- FIGURE 3.5.5 (e) - Sections of pre-cast HS door frame panel with ventilation sleeve at its side (Type 1)
- FIGURE 3.5.5 (f) - Plan of HS with pre-cast HS door frame panel (Type 2)
- FIGURE 3.5.5 (g) - Details and sections of pre-cast HS door frame panel with ventilation sleeve above it (Type 2)
- FIGURE 3.5.5 (h) - Sections of pre-cast HS door frame panel with ventilation sleeve above it (Type 2)
- FIGURE 3.5.5 (i) - Details and sections of pre-cast HS door frame panel with ventilation at its side (Type 2)
- FIGURE 3.5.5 (j) - Sections of pre-cast HS door frame panel with ventilation at its side (Type 2)
- FIGURE 3.5.5 (k) - Plan of HS with pre-cast HS door frame panel (Type 3)
- FIGURE 3.5.5 (l) - Details of pre-cast HS door frame panel (Type 3)
- FIGURE 3.5.5 (m) - Sections of pre-cast HS door frame panel (Type 3)
- FIGURE 3.5.5 (n) - Sections of pre-cast HS door frame panel (Type 3)

3.5.6 Precast HS Hollow Core

Precast HS Hollow Core shall comply with the dimensions, reinforcement bar and connection detail requirements as shown in the following tables and figures:

- TABLE 3.5.6 (a) - Dimension of Precast Hollow Cores HS
- TABLE 3.5.6 (b) - HS wall thickness and Sizes of Hollow Cores
- TABLE 3.5.6 (c) - Minimum Reinforcement Bars in Hollow Cores
- TABLE 3.5.6 (d) - Minimum Thickness of Slab and Reinforced Concrete Topping
- FIGURE 3.5.6.1 (a) - Precast HS with HS door on longer wall and one of the ventilation sleeves above the door (Type 1)
- FIGURE 3.5.6.1 (b) - Precast HS with HS door on shorter wall and one of the ventilation sleeves above the door (Type 2)
- FIGURE 3.5.6.1 (c) - Precast HS showing ventilation sleeve and internal electrical fixtures on the same wall (Type 3)
- FIGURE 3.5.6.1 (d) - Precast HS and C-shaped Precast HS connected at the shorter wall and with HS door on longer walls (Type 4)

- FIGURE 3.5.6.1 (e) - Precast HS and C-shaped Precast HS connected at the longer wall and with HS door on longer walls (Type 5)
- FIGURE 3.5.6.1 (f) - Precast HS and C-shaped Precast HS connected at the longer wall and with HS door each on the longer wall and shorter wall (Type 5A)
- FIGURE 3.5.6.1 (g) - Precast HS and C-shaped Precast HS with connection between longer and shorter walls respectively and with HS doors on longer wall (Type 6)
- FIGURE 3.5.6.1(h) - Precast HS and C-shaped Precast HS with connection between longer and shorter walls respectively and with HS door each on longer wall and shorter wall (Type 6A)
- FIGURE 3.5.6.2 (a) - Reinforcement Bar Details of Wall, Rib and Blast Door on Long Wall of Precast HS
- FIGURE 3.5.6.2 (b) - Reinforcement Bar Details of Wall, Rib and Blast Door on Short Wall of Precast HS
- FIGURE 3.5.6.2 (c) - Plan and Section of Rib with Shear Links
- FIGURE 3.5.6.2 (d) - Reinforcement Bar Details of Wall and Rib for C-Shaped Precast HS
- FIGURE 3.5.6.2 (e) - Reinforcement Bar Details of Wall and Rib for C-Shaped Precast HS
- FIGURE 3.5.6.2 (f) - Connection Details Between Two Precast HS
- FIGURE 3.5.6.2 (g) - Connection Details Between Precast HS and Cast In-Situ Wall/ Column
- FIGURE 3.5.6.2 (h) - Reinforcement Bar Details at Concrete Rib
- FIGURE 3.5.6.2 (i) - Details of Reinforcement Bars near Door Frame and at Electrical Fixtures on Internal Face of Precast HS
- FIGURE 3.5.6.2 (j) - Details of Trimmer Bars for Ventilation Sleeve
- FIGURE 3.5.6.2 (k) - Details of Trimmer Bars for Wall Recess for HS Door Handle
- FIGURE 3.5.6.2 (l) - Precast HS Wall with Connection Details for Ventilation Sleeve and Electrical Services
- FIGURE 3.5.6.2 (m) - Precast HS Wall with Connection Details for Electrical Services
- FIGURE 3.5.6.2 (n) - Cage Reinforcement Bars in Hollow Cores
- FIGURE 3.5.6.2 (o) - Reinforcement Bars Lapping in Hollow Cores

- FIGURE 3.5.6.2 (p) - Hollow Cores Shape
- FIGURE 3.5.6.3 (a) - Isometric View of Precast HS with Bolts and Steel Plates Connection (Type 1 without Blocked-Out for Beam)
- FIGURE 3.5.6.3 (b) - Isometric View of Precast HS with Bolts and Steel Plates Connection (Type 2 without Blocked-Out for Beam)
- FIGURE 3.5.6.3 (c) - Splice Sleeve Connection Details Between Precast HS and Cast In-Situ Element and Bolt Connection Details Between Two Precast HS
- FIGURE 3.5.6.3 (d) - Splice Sleeve Connection Details for Precast HS Tower
- FIGURE 3.5.6.3 (e) - Connection Details Between lower and upper Precast HS (Detail A)
- FIGURE 3.5.6.3 (f) - Connection Details Between lower and upper Precast HS (Detail B)
- FIGURE 3.5.6.3 (g) - Connection Details Between lower and upper Precast HS (Detail C)
- FIGURE 3.5.6.3 (h) - Isometric View of Precast HS with Splice Sleeve Connection (Reinforcement Bars Details)
- FIGURE 3.5.6.3 (i) - Detail of Splice Sleeve Connection
- FIGURE 3.5.6.3 (j) - Details of Precast Plank (marked as PS) and Concrete Topping
- FIGURE 3.5.6.3 (k) - Electrical Fixtures on External Face of Precast HS
- FIGURE 3.5.6.3 (l) - Isometric View of Precast HS with Bolts and Steel Plates Connection (Type 3 with Blocked-Out for Beam)
- FIGURE 3.5.6.3 (m) - Isometric View of Precast HS with Bolts and Steel Plates Connection (Type 4 with Blocked-Out for Beam)

3.5.7 **Joints**

- (a) Construction joints in an HS tower shall be properly executed to ensure that the strength and the integrity of the HS are not impaired. The type and location of joints shall be specified in the design after taking into account the following:
 - (i) A concrete kicker, if provided, shall not be more than 100 mm high.
 - (ii) All HS walls located within each storey shall be cast in one operation.
- (b) Expansion joints or contraction joints in the HS tower are not permitted.

3.6 PENETRATION OF SERVICES

3.6.1 Electrical Services

- (a) All service conduits shall not penetrate through the walls and slabs of the HS. Service conduits for electrical service cables which are cast in the external face of HS can be embedded in the HS wall. Other than this, all service conduits which do not serve the HS shall not be embedded within the HS walls and slabs.
- (b) Two cast-in service outlets located directly back to back on the internal and external faces of the HS wall are not permitted (See FIGURE 3.6.1(b)). Service outlets shall be fixed with at least a clear distance of 300 mm between each other (See FIGURE 2.13).
- (c) Risers for services can be mounted on the external face of HS towerwalls.
- (d) Where service cables and fixtures in the HS are exposed on internal walls, non-metallic inserts are to be used for their mounting. For embedded service cables and fixtures serving the HS, the details as shown in FIGURE 3.5.4(g) shall be followed. The encasement for the switch, 13A switched socket outlet, TV and communication line for telephony outlets of Clause 2.7 shall be made of hot-dipped galvanised steel construction (See FIGURE 3.6.1(d)).
- (e) A maximum of 4 numbers of 25 mm diameter conduits are allowed to be embedded within the HS walls for electrical cables serving fixtures in the HS. Both ends of these conduits on the internal and the external of the HS shall be fully sealed with sealing material in accordance with the manufacturer's specification and up to a depth of not less than 100 mm into the conduits to ensure air-tightness of HS.

3.6.2 Water and Gas Services

Service pipes for water or gas are allowed to penetrate through the HS walls provided that they are laid inside a stainless steel casing encased by 150 mm reinforced concrete all round (See FIGURE 3.6.2). Joints in water pipe, gas pipe or the stainless steel conduit shall be located outside the HS.

3.6.3 Refuse Chute or/ and Services Risers within the setback distance of HS

Refuse chute and risers for water and gas services can be mounted on the external face of HS walls. Where this structure protrudes above the roof, it shall be designed with a minimum 300mm reinforced concrete all round and reinforcement details as shown in FIGURES 3.6.3(a) to 3.6.3(c).

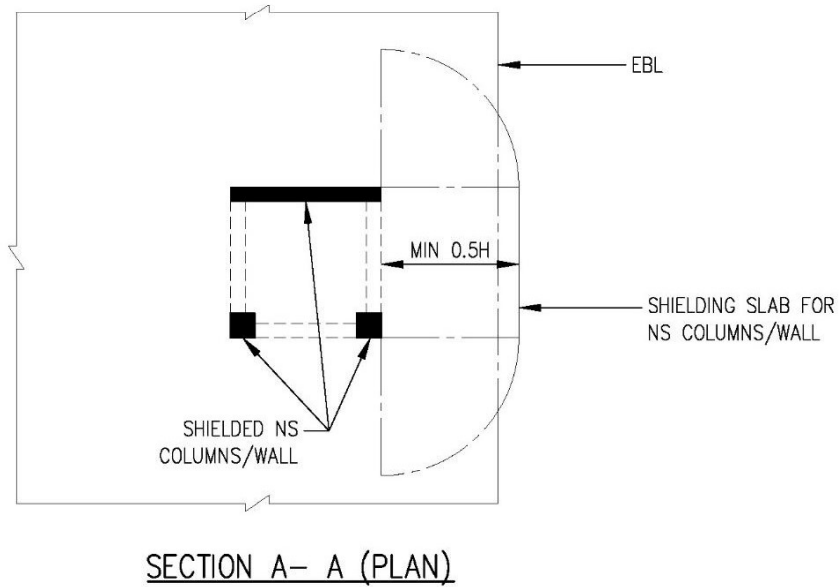
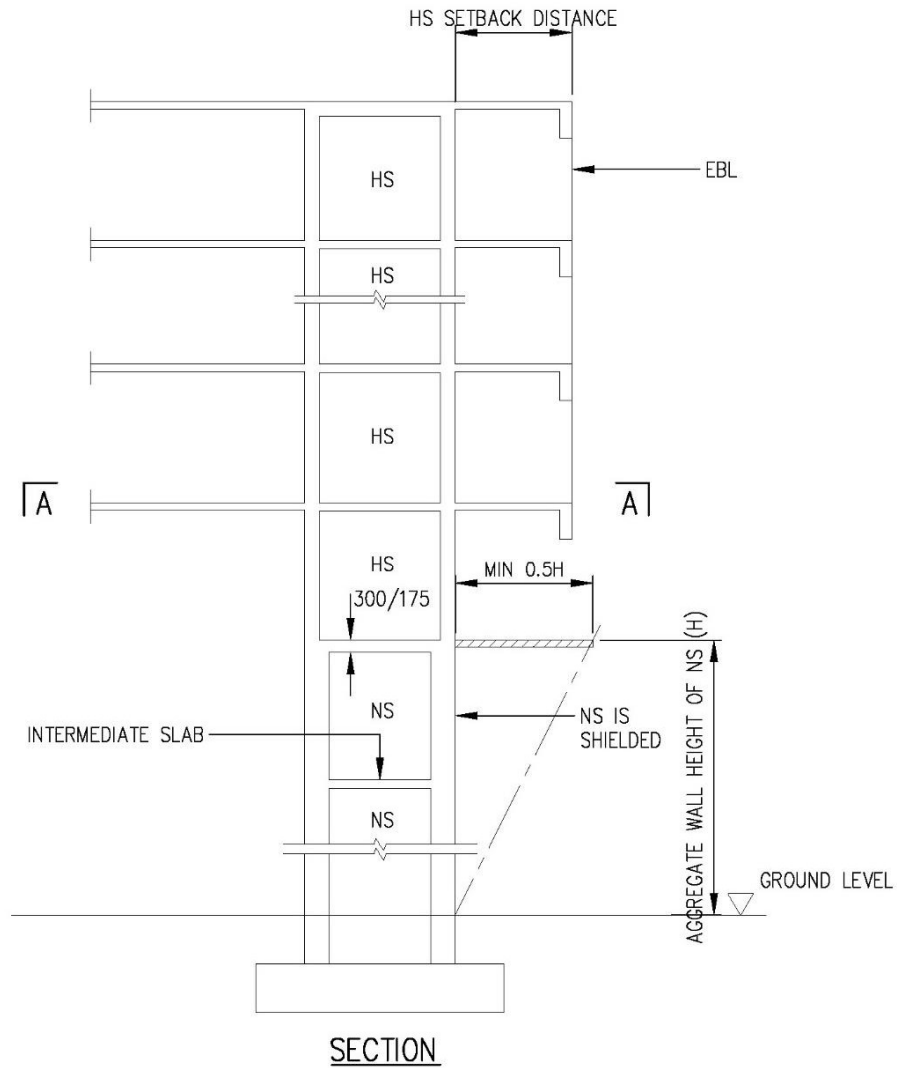

FIGURE 3.3.3 SHIELDED NS WALLS AND/OR NS COLUMNS

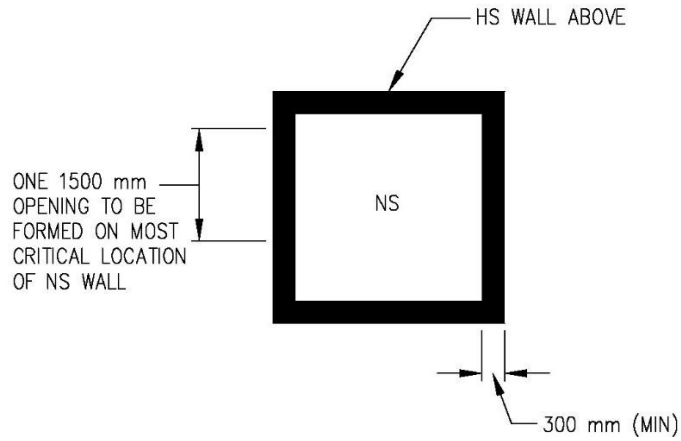

FIGURE 3.3.4(a) UNSHIELD NS WALL(S)

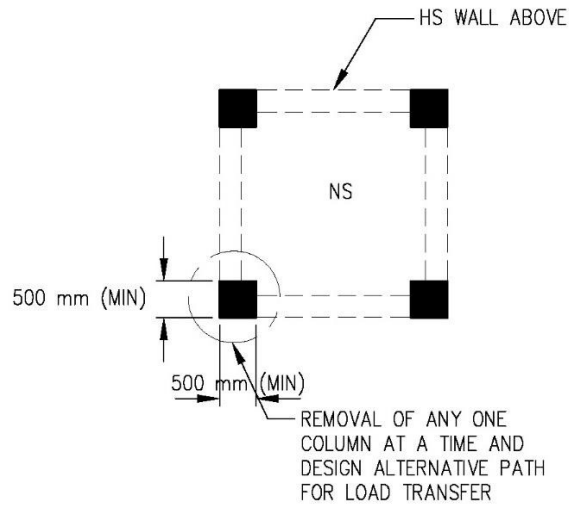

FIGURE 3.3.4(b) UNSHIELD NS COLUMN(S)

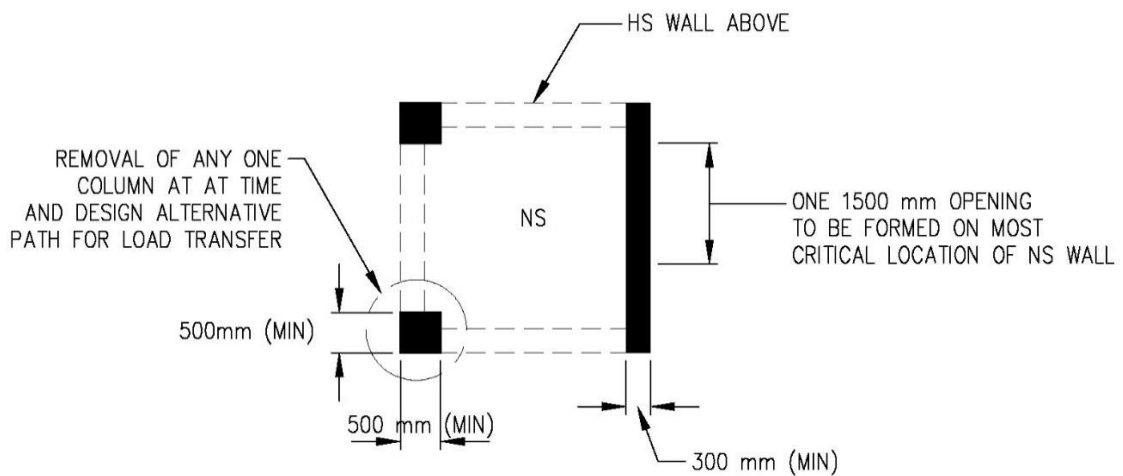

FIGURE 3.3.4(c) COMBINATION OF UNSHIELD NS WALL(S) AND/OR NS COLUMN(S)

TABLE 3.3.4 (d): ACTION COMBINATION AND VALUES OF PARTIAL SAFETY FACTORS (γ_f) FOR ULTIMATE LIMIT STATE

Action Combination	Permanent Actions		Variable Actions		Earth/Water Pressure Load, if applicable
	Favourable	Unfavourable	Imposed Load	Wind Load	
Permanent and Variable (imposed load, wind load), earth/water pressure load, if applicable)	1.0	1.0	1.0	1.0	1.0

TABLE 3.3.5.1 DESIGN VALUES OF ACTIONS OF PARTIAL SAFETY FACTORS (γ_f) FOR ULTIMATE LIMIT STATE

(DESIGN AGAINST COLLAPSE LOAD AND UNSHIELDED/SHIELDED TRANSFER STRUCTURE)

Actions	Permanent Actions		Variable Actions		
	Favourable	Unfavourable	Leading Variable Action	Accompanying Variable Actions (Earth, Wind and Water Pressure)	Accompanying Variable Action (Collapse)
Permanent and Variable (imposed load, wind load), earth/water pressure load, if applicable)	1.0	1.0	1.3	1.3	1.0

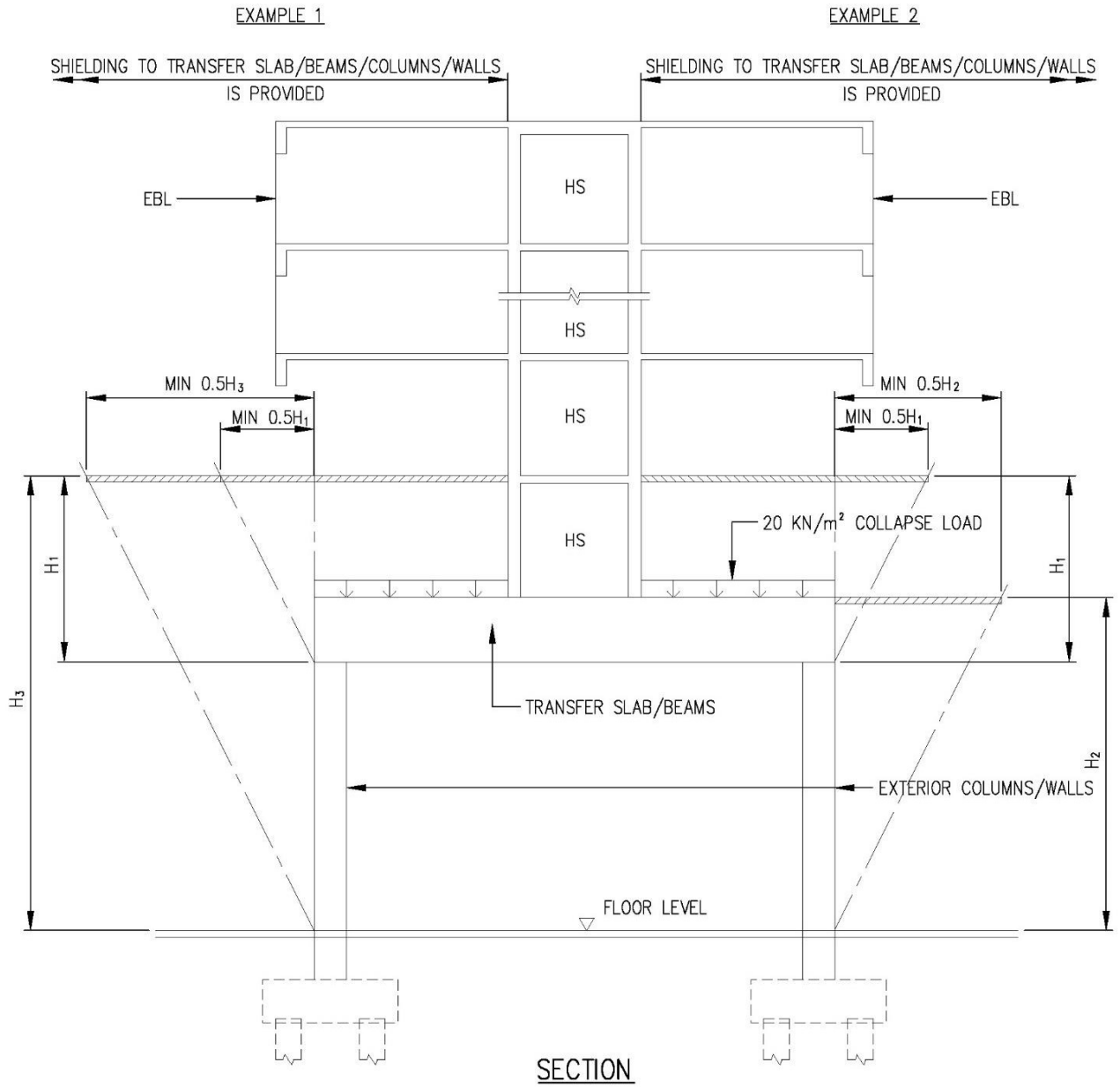

FIGURE 3.3.5.2(a) SHIELDED TRANSFER SYSTEM THAT SUPPORTS HS TOWER

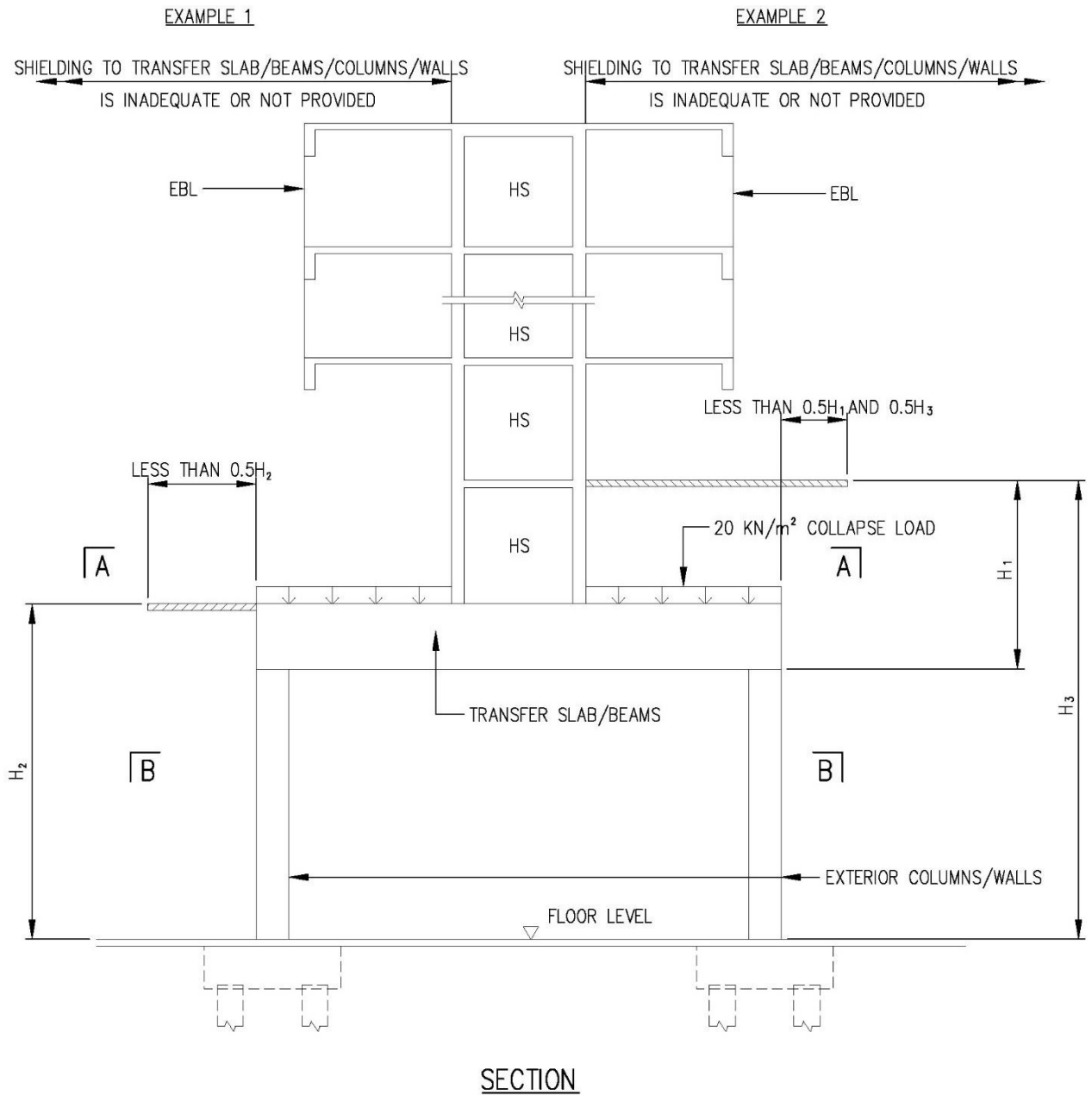

FIGURE 3.3.5.3 UNSHIELDED TRANSFER SYSTEM THAT SUPPORTS HS TOWER (UNSHIELDED SLAB/BEAM OR/AND COLUMNS/WALLS)

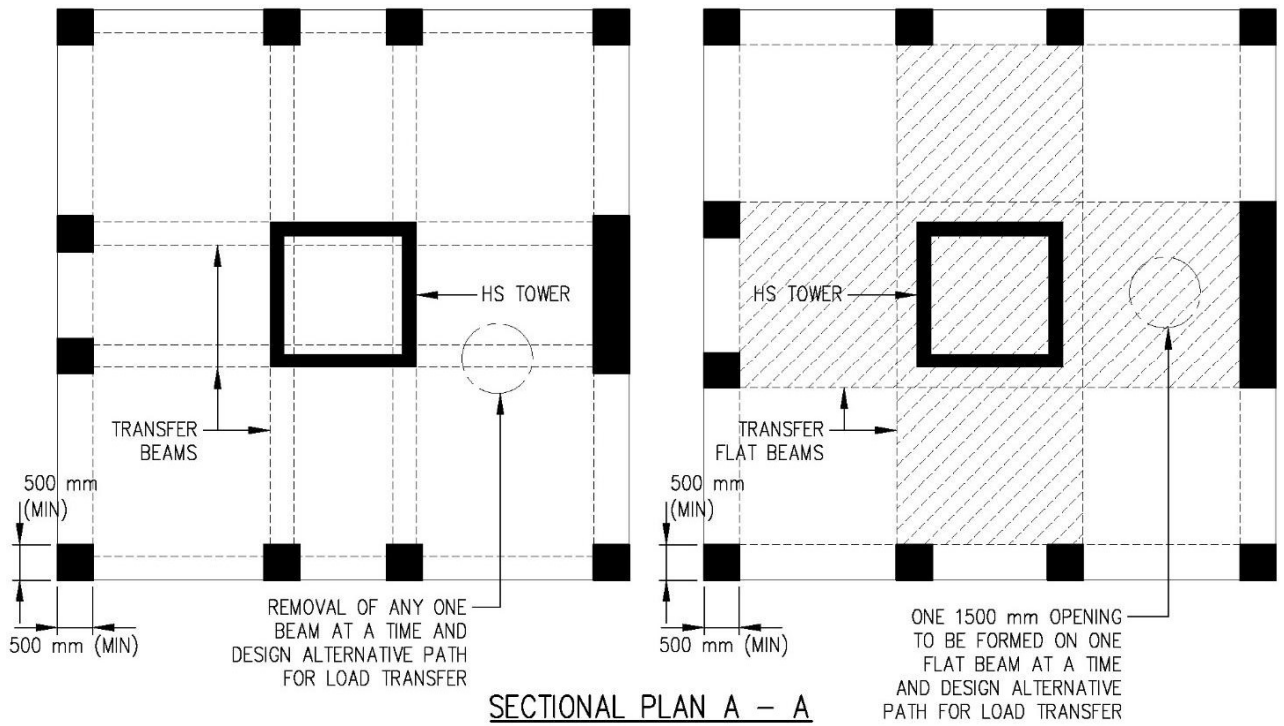

FIGURE 3.3.5.3a(i) UNSHIELDED TRANSFER BEAMS

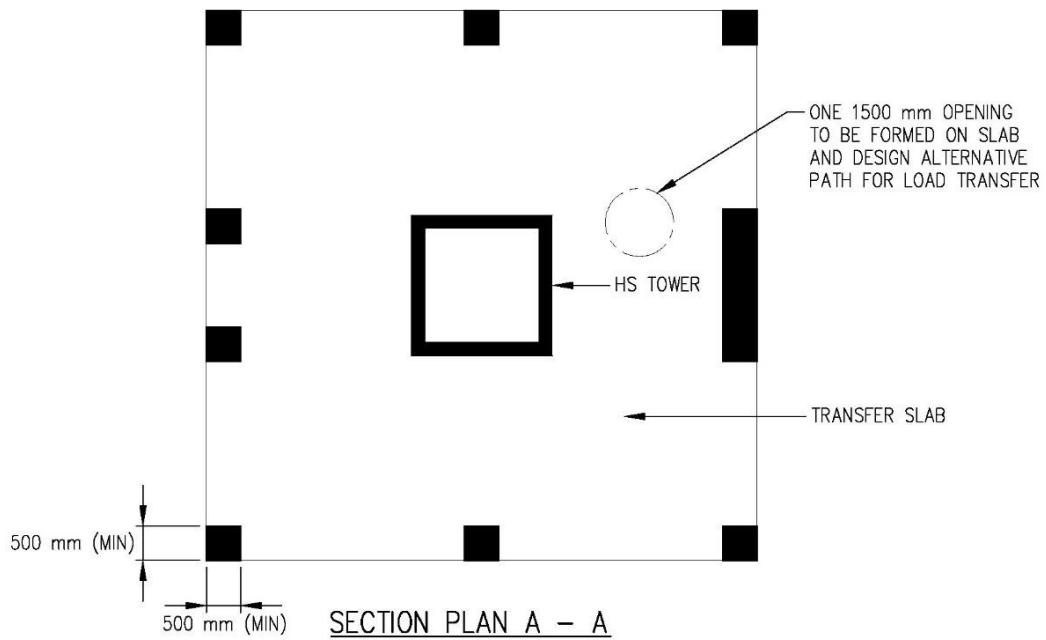
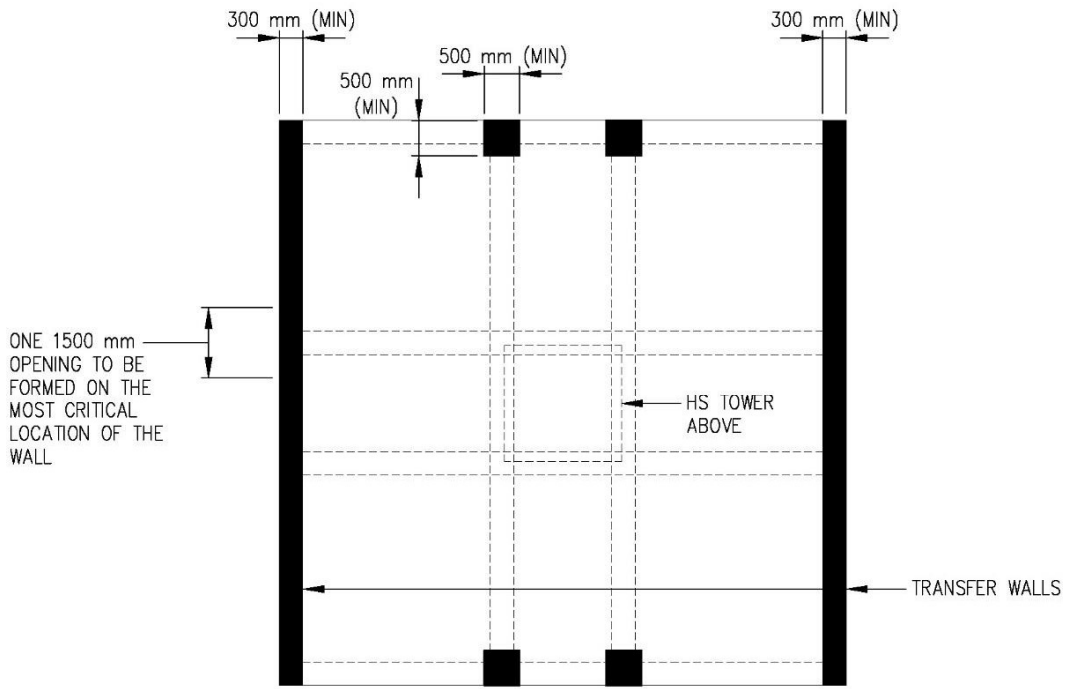
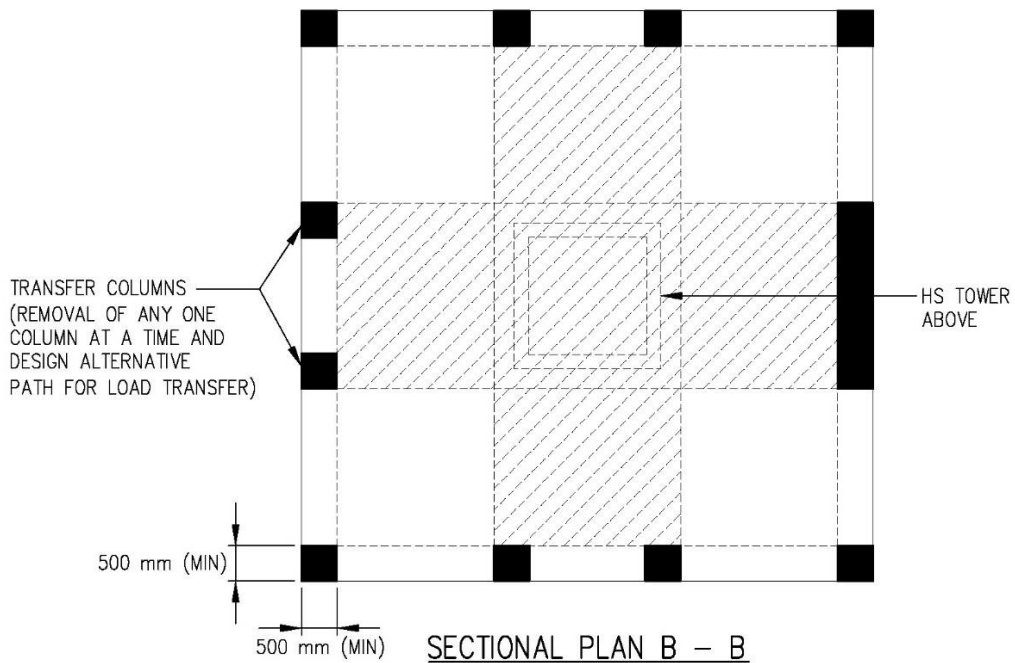

FIGURE 3.3.5.3a(ii) UNSHIELDED TRANSFER SLAB



SECTIONAL PLAN B - B

FIGURE 3.3.5.3b(i) UNSHIELDED TRANSFER WALLS



SECTIONAL PLAN B - B

FIGURE 3.3.5.3b(ii) UNSHIELDED TRANSFER COLUMNS

TABLE 3.4.2.1(a): MINIMUM REINFORCEMENT OF HS WALLS FOR LANDED DEVELOPMENTS

HS Clear Height (mm)	Reinforcements at both internal and external faces of wall (both directions)	Shear Links (both directions)
$2400 \leq H_t \leq 3900$	H10 - 100	H8 - 600

TABLE 3.4.2.1(b): MINIMUM REINFORCEMENT OF HS AND NS WALLS FOR NON-LANDED DEVELOPMENTS

HS or NS Clear Height (mm)	Reinforcements at both internal and external faces of wall (both directions)	Shear Links (both directions)
$2400 \leq H_t \leq 3000$	H10 - 100	H8 - 600
$3000 < H_t \leq 3900$	H13 - 100	H8 - 600

**TABLE 3.5.2(a): LAP AND ANCHORAGE LENGTHS
(CONCRETE GRADE C25/30 FOR LANDED DEVELOPMENTS)**

Type of Reinforcement Bar Length	Reinforcements bar diameter \emptyset (mm)	
	$10 \leq \emptyset \leq 16$	$16 < \emptyset \leq 28$
Minimum Anchorage Length	$37 \emptyset$	$41 \emptyset$
Minimum Lap Length	$55 \emptyset$	$61 \emptyset$

**TABLE 3.5.2(b): LAP AND ANCHORAGE LENGTHS
(CONCRETE GRADE C32/40 FOR LANDED AND NON-LANDED DEVELOPMENTS)**

Type of Reinforcement Bar Length	Reinforcements bar diameter \emptyset (mm)	
	$10 \leq \emptyset \leq 16$	$16 < \emptyset \leq 28$
Minimum Anchorage Length	$37 \emptyset$	$37 \emptyset$
Minimum Lap Length	$47 \emptyset$	$52 \emptyset$

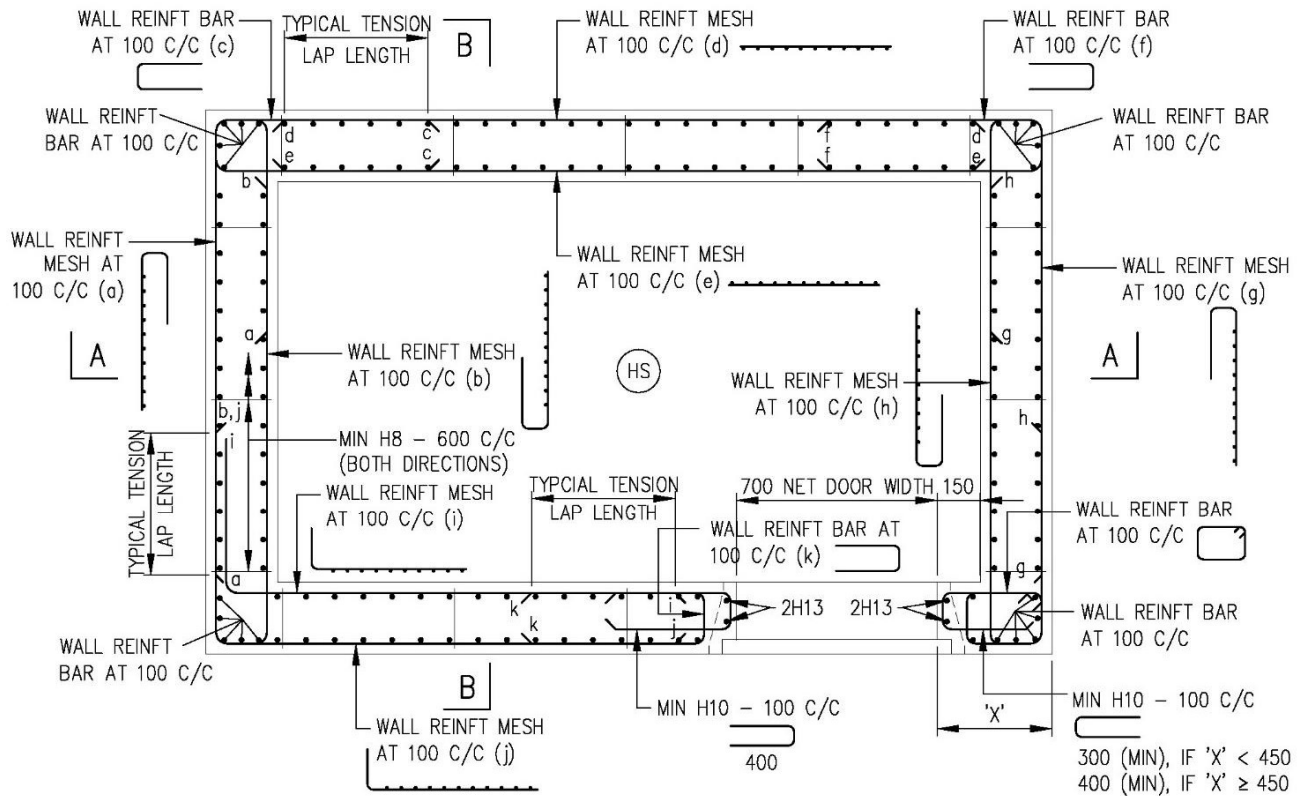

PLAN OF HS WALL AT DOOR OPENING

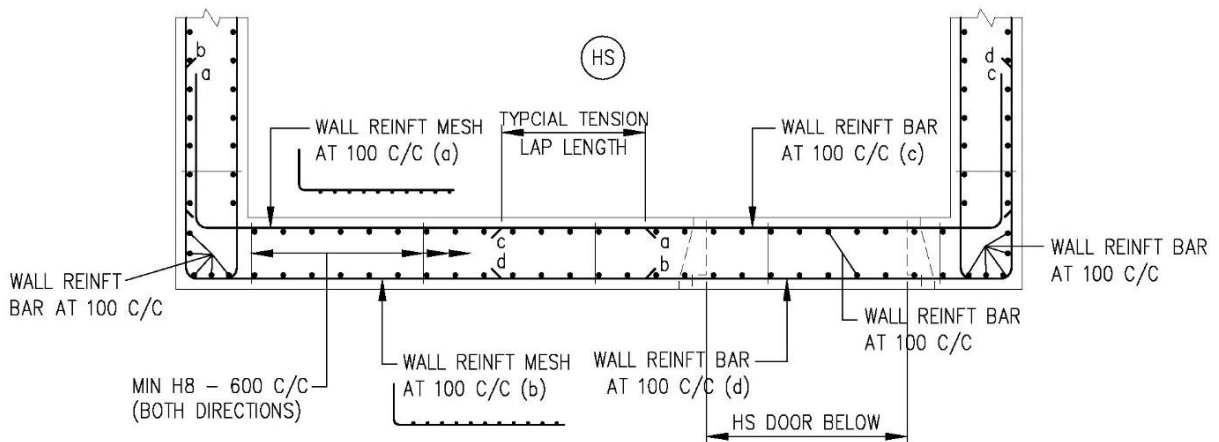

PLAN OF HS WALL ABOVE DOOR OPENING

NOTE:

1. WALL REINFORCEMENT REFER TO TABLE 3.4.2.1(a) FOR LANDED DEVELOPMENT OR TABLE 3.4.2.1(b) FOR NON-LANDED DEVELOPMENT

FIGURE 3.5.4(a) PLAN OF HS

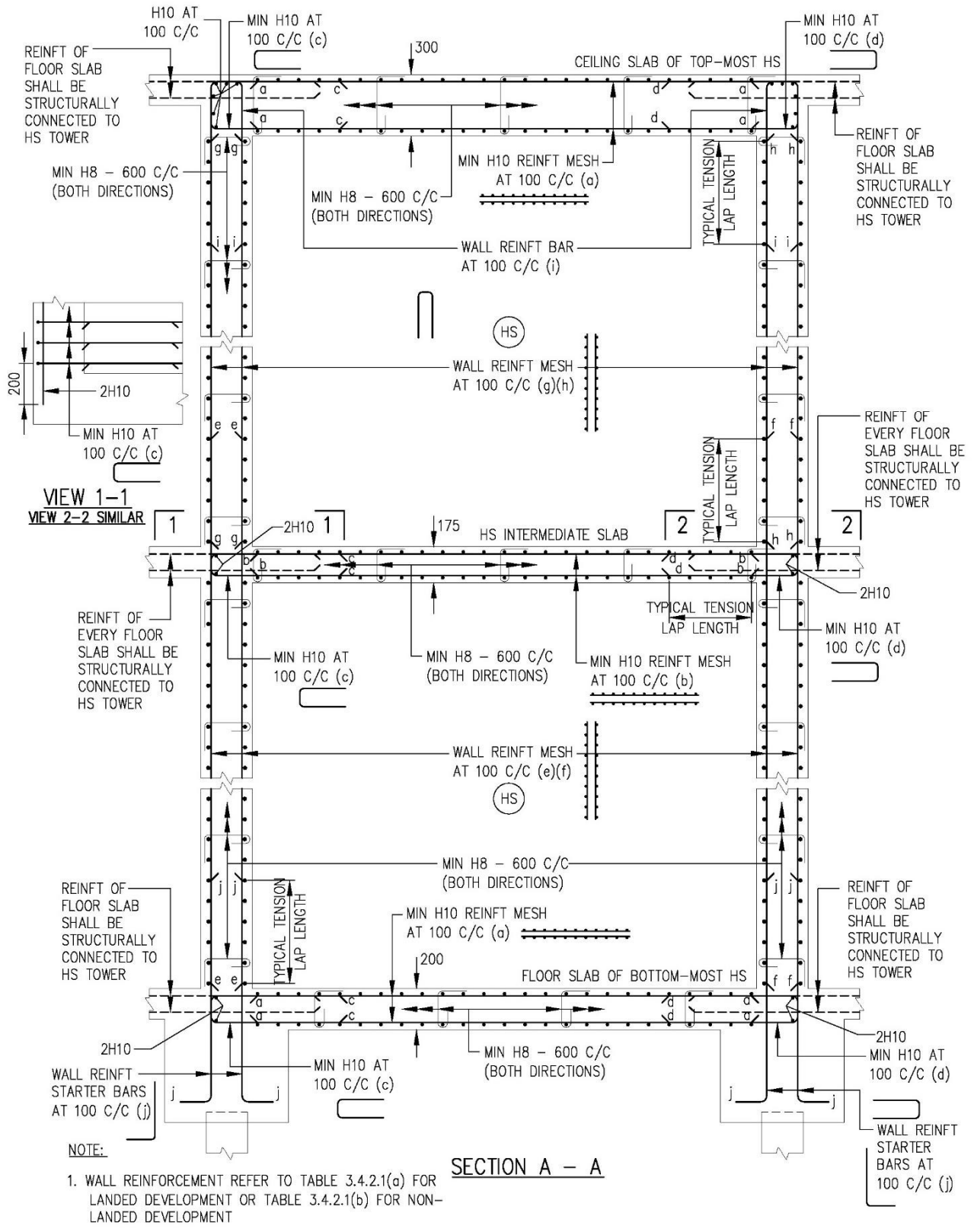

FIGURE 3.5.4(b) SECTIONAL DETAILS OF HS SLABS/WALLS

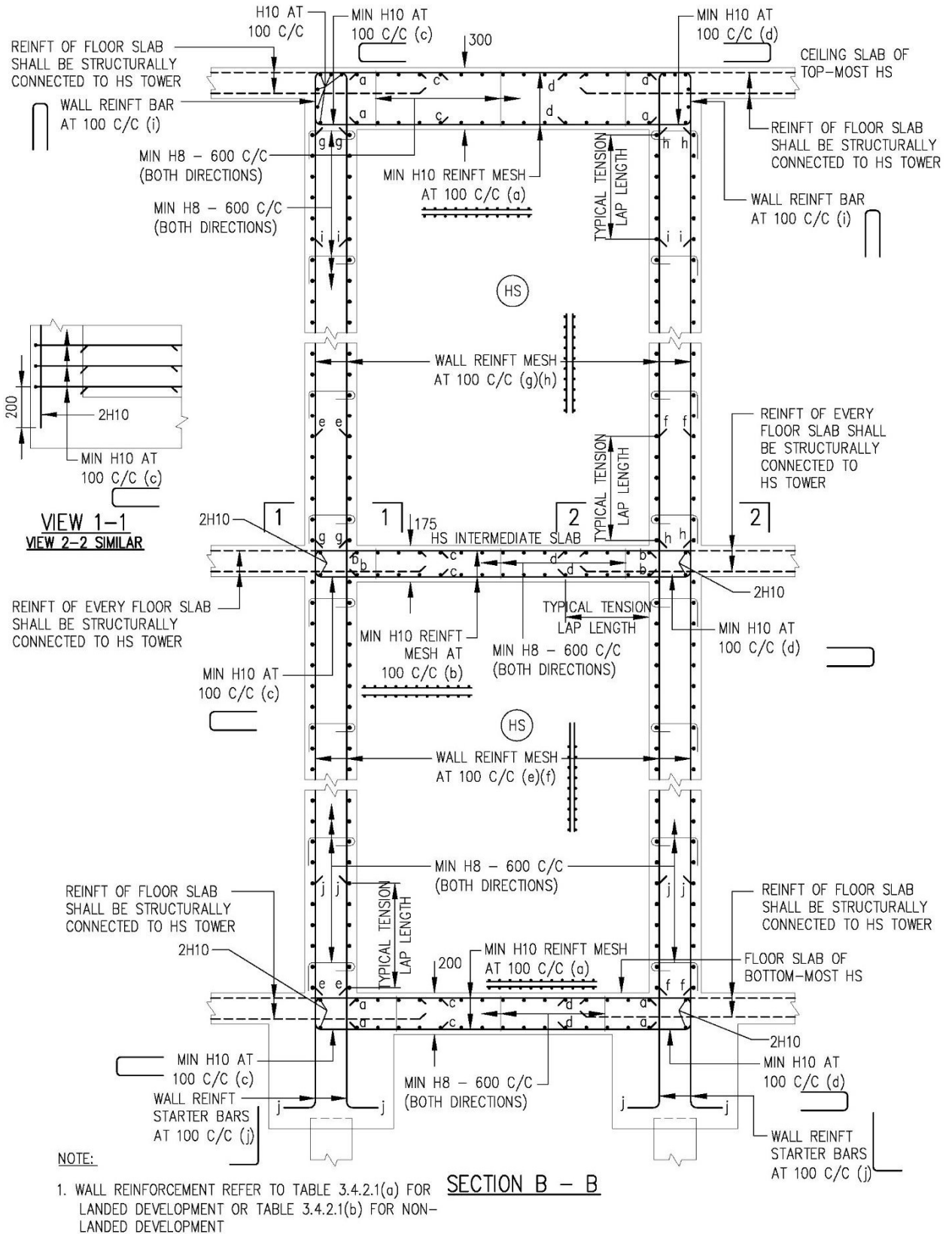
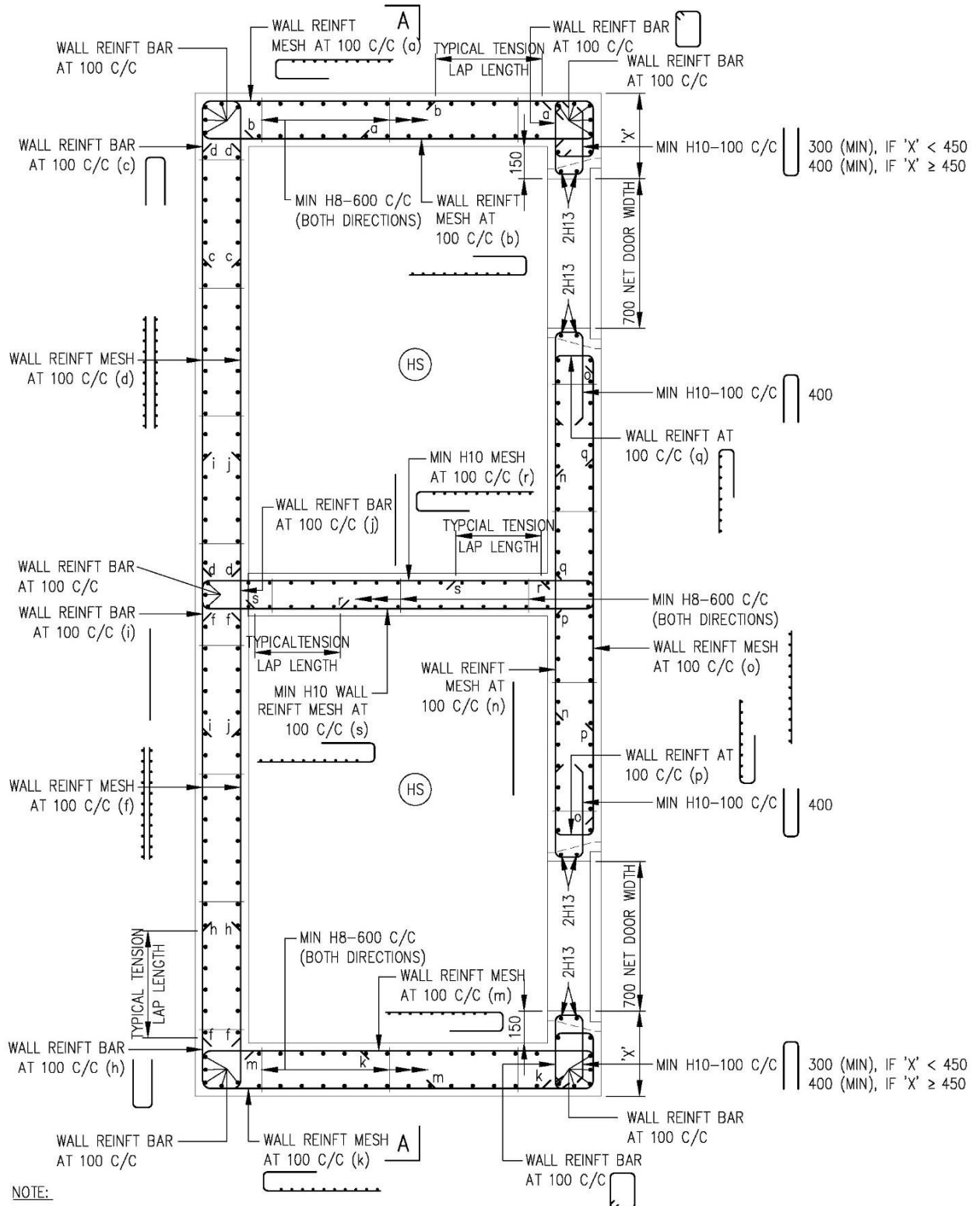

FIGURE 3.5.4(c) SECTIONAL DETAILS OF HS SLABS/WALLS



NOTE:

1. WALL REINFORCEMENT REFER TO TABLE 3.4.2.1(a) FOR LANDED DEVELOPMENT OR TABLE 3.4.2.1(b) FOR NON-LANDED DEVELOPMENT

FIGURE 3.5.4(d) PLAN OF TWO HS WITH INTERNAL COMMON WALL

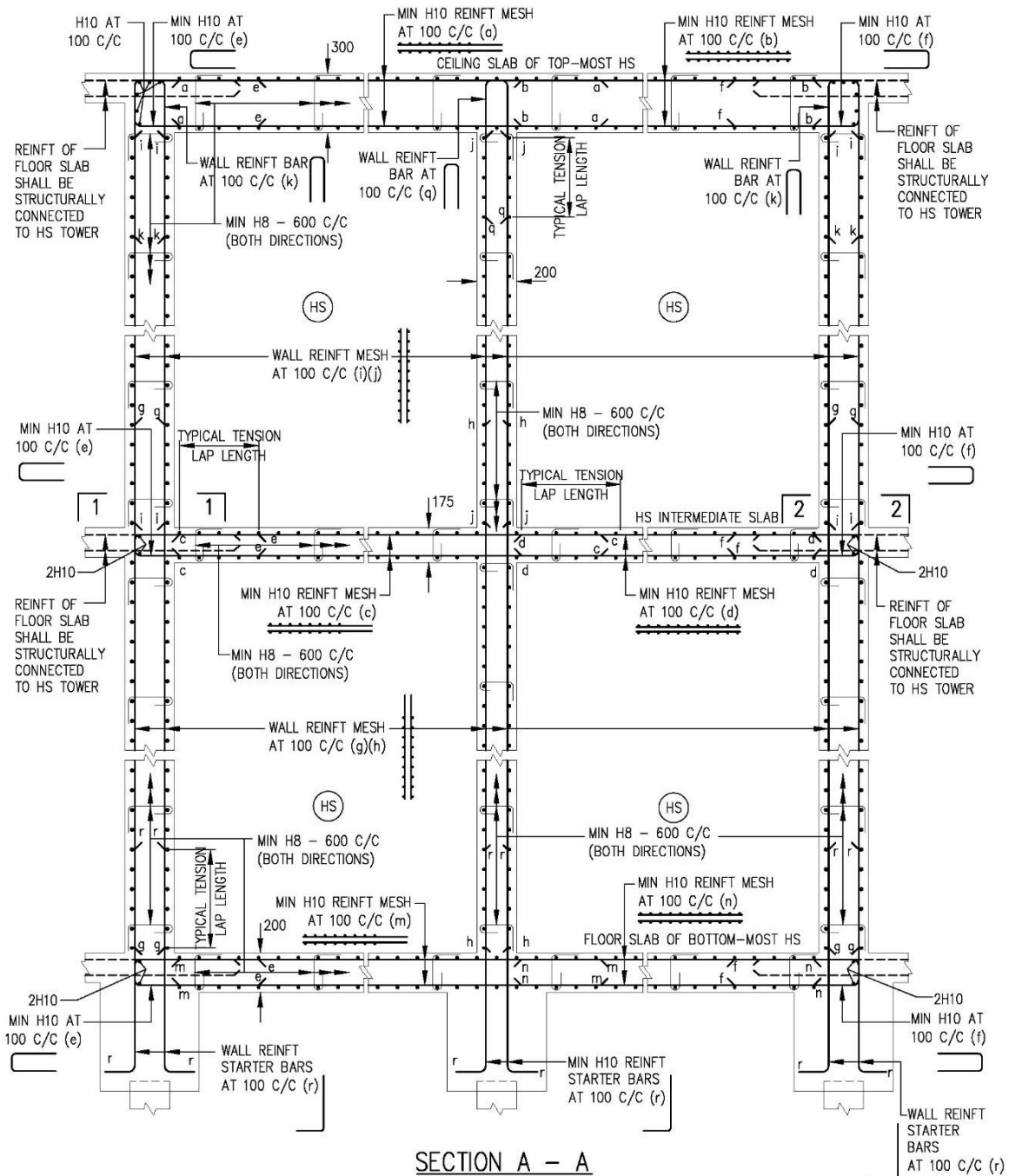

NOTE:

1. WALL REINFORCEMENT REFER TO TABLE 3.4.2.1(a) FOR LANDED DEVELOPMENT OR TABLE 3.4.2.1(b) FOR NON-LANDED DEVELOPMENT

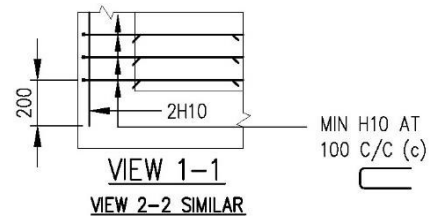
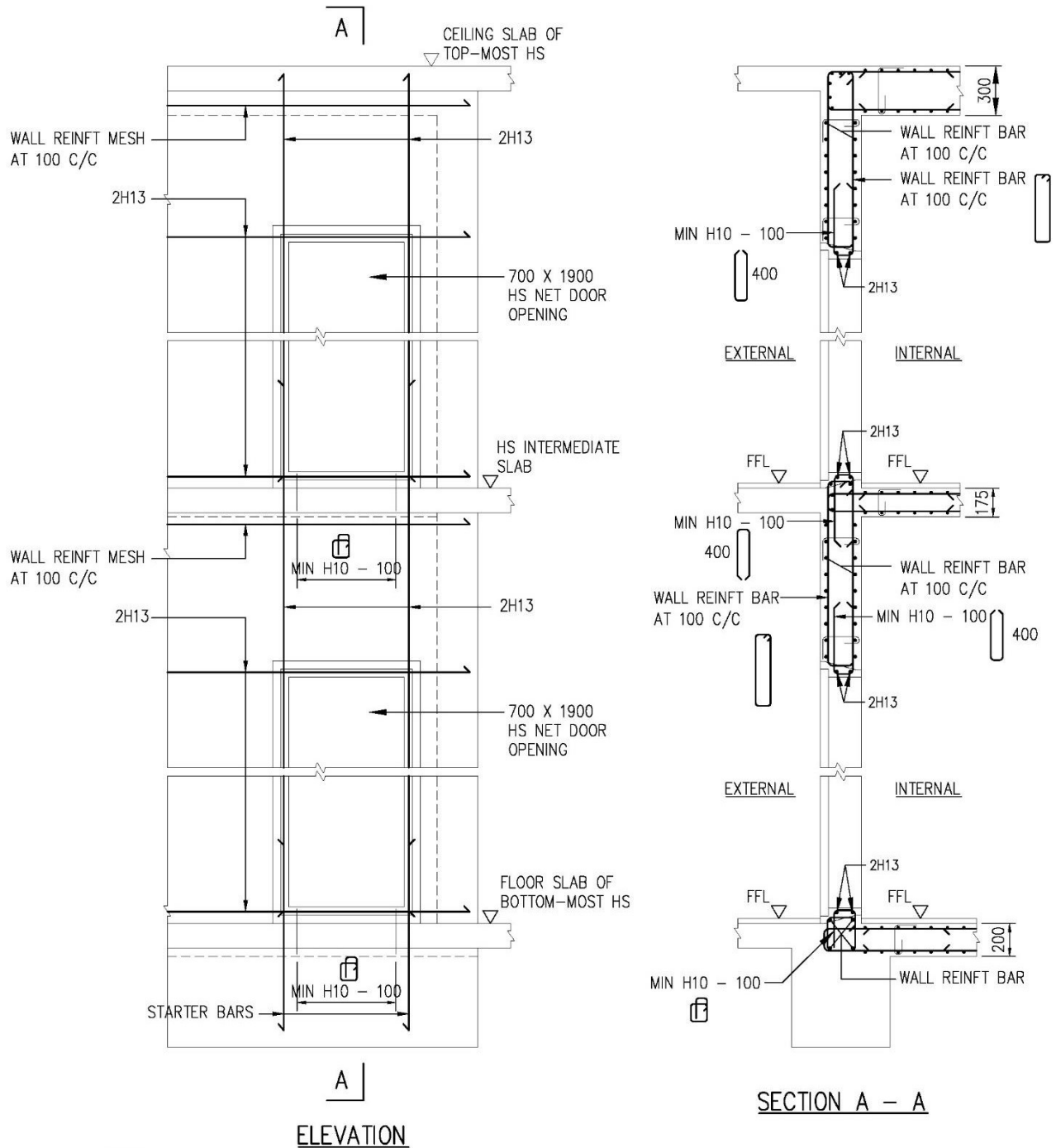

FIGURE 3.5.4(e) SECTIONAL DETAILS OF TWO HS WITH AN INTERNAL COMMON WALL



NOTE:

1. WALL REINFORCEMENT REFER TO TABLE 3.4.2.1(a) FOR LANDED DEVELOPMENT OR TABLE 3.4.2.1(b) FOR NON-LANDED DEVELOPMENT

FIGURE 3.5.4(f) DETAILS OF HS WALL REINFORCEMENT BAR NEAR HS DOOR

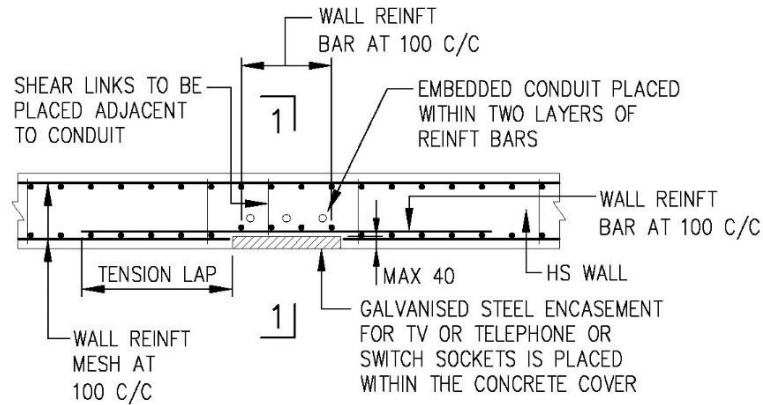

PLAN
(IF REINFORCEMENT BARS ARE CUT)

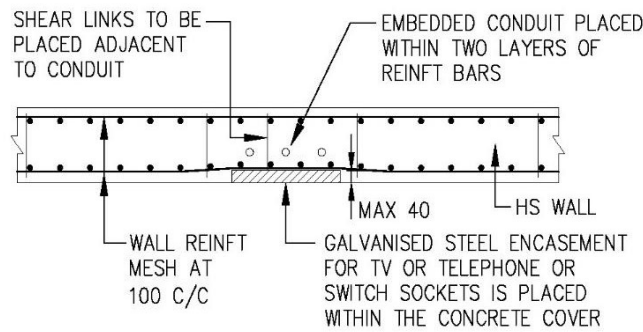

PLAN
(REINFORCEMENT BARS ARE NOT CUT)

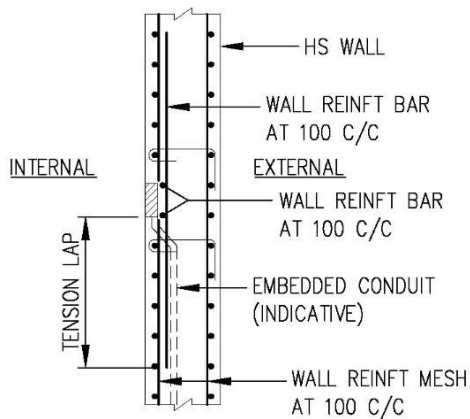

SECTION 1 – 1

NOTE:

1. WALL REINFORCEMENT REFER TO TABLE 3.4.2.1(a) FOR LANDED DEVELOPMENT OR TABLE 3.4.2.1(b) FOR NON-LANDED DEVELOPMENT

**FIGURE 3.5.4(e) TYPICAL DETAILS OF EMBEDDED CONDUIT
IN HS WALL**

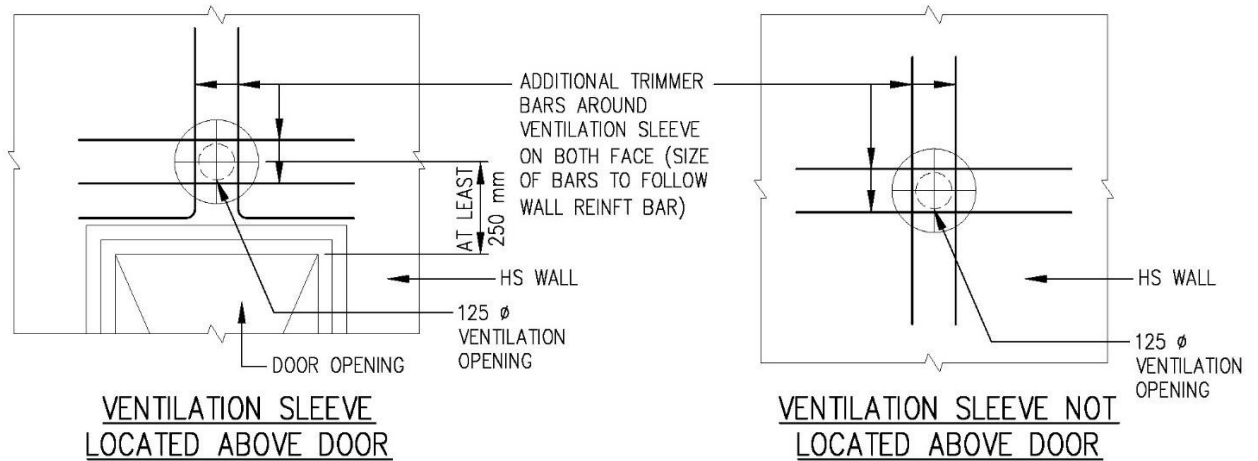
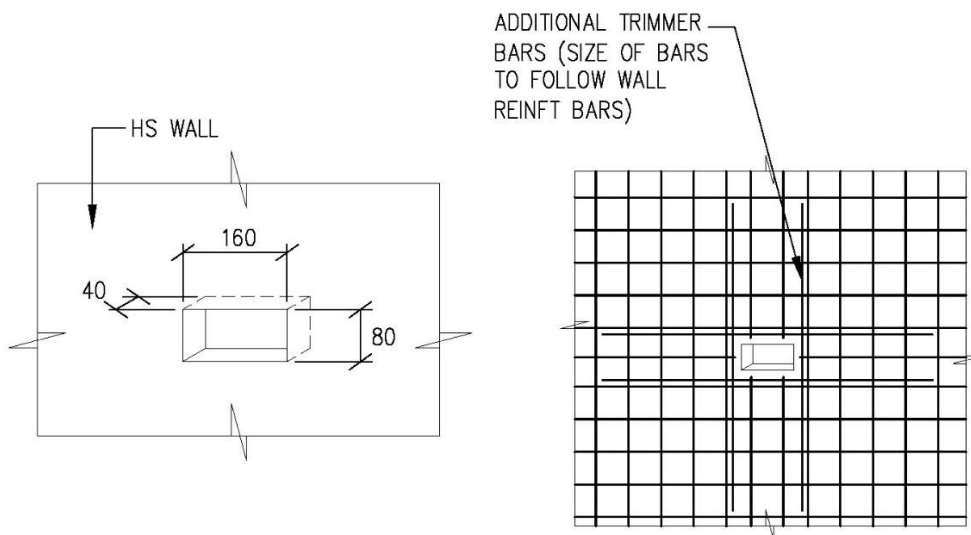
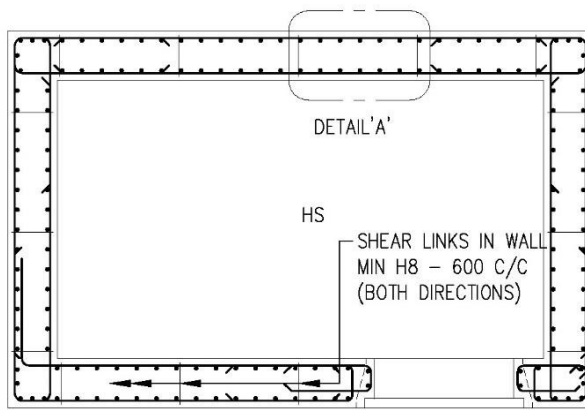

FIGURE 3.5.4(h) TYPICAL DETAILS OF TRIMMER BARS FOR VENTILATION SLEEVE



**ELEVATION OF WALL RECESS
(IF WALL REINFORCEMENT BARS ARE CUT FOR WALL RECESS)**

FIGURE 3.5.4(i) TYPICAL DETAILS OF TRIMMER BARS FOR WALL RECESS



PLAN OF HS SHOWING SHEAR LINKS ARRANGEMENT

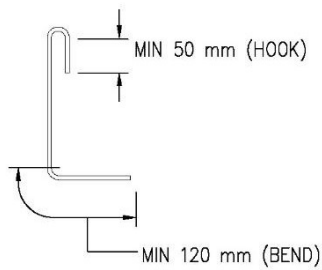

MINIMUM HOOK AND BEND ALLOWANCE FOR SHEAR LINKS (H8)

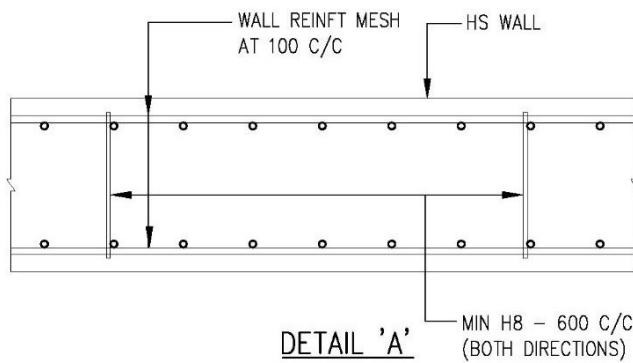

NOTE:

1. WALL REINFORCEMENT REFER TO TABLE 3.4.2.1(a) FOR LANDED DEVELOPMENT OR TABLE 3.4.2.1(b) FOR NON-LANDED DEVELOPMENT
2. THE HOOK AND THE BEND OF H8 LINKS MUST BE TIED TO OUTERMOST REINFORCEMENT BARS OF HS WALL WHERE THE HOOK MUST ALWAYS BE PLACED NEAR TO INTERNAL FACE OF HS WALL.

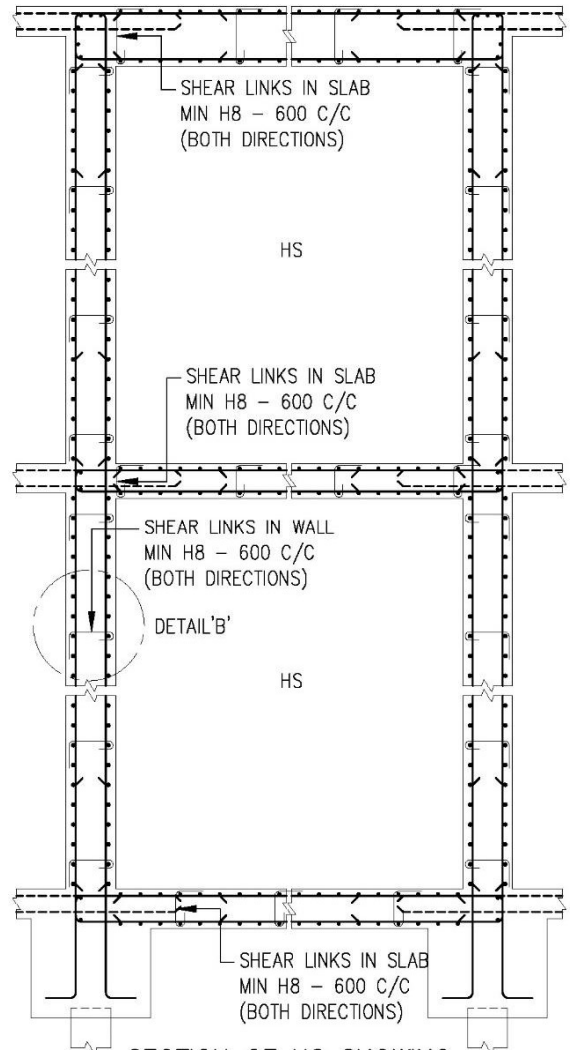

SECTION OF HS SHOWING SHEAR LINKS ARRANGEMENT

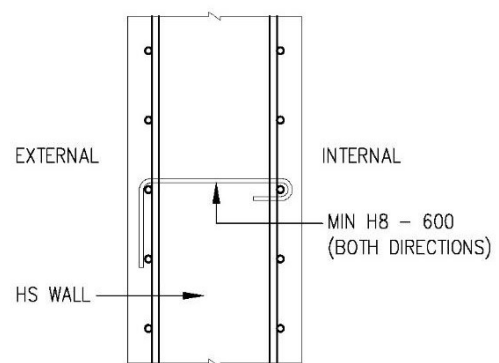

DETAIL 'B'

FIGURE 3.5.4(j) DETAILS OF SHEAR LINKS IN HS SLABS/WALLS

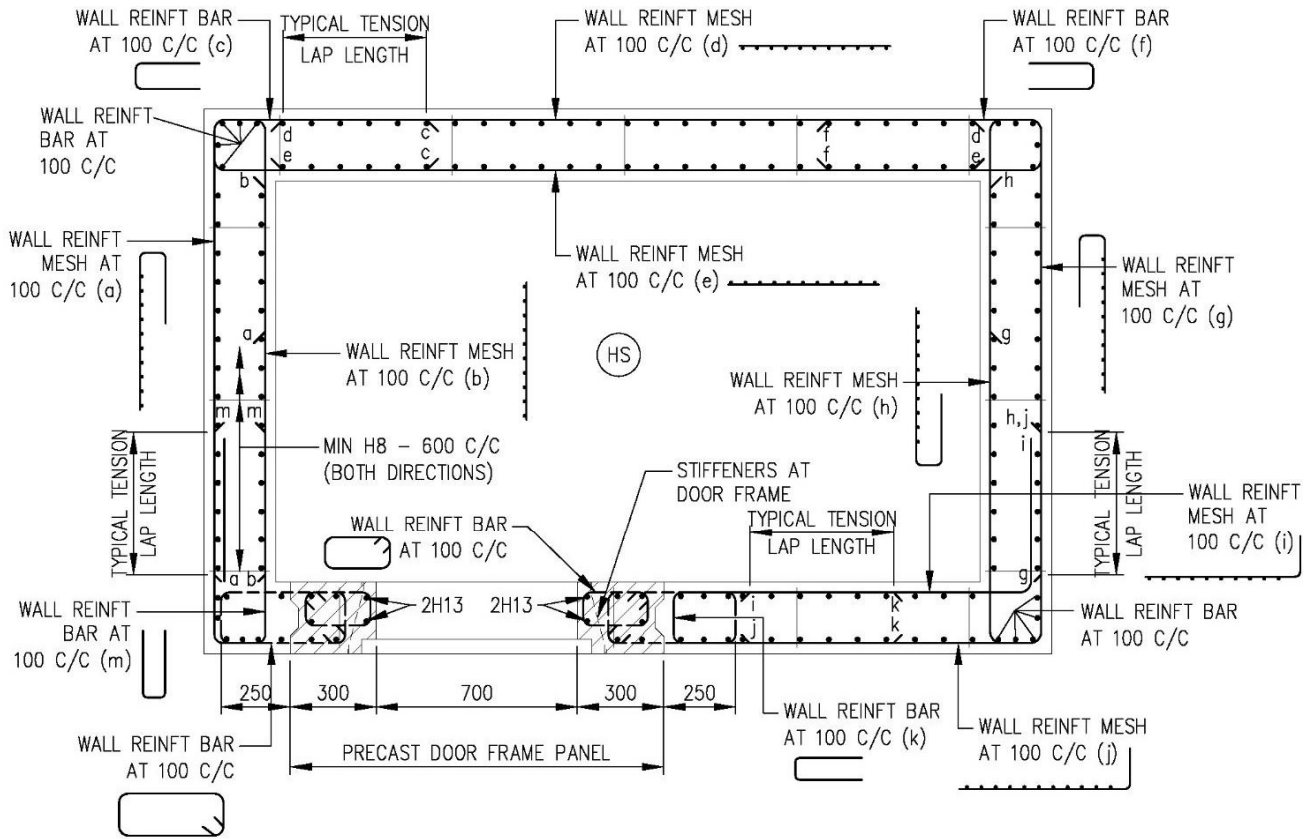
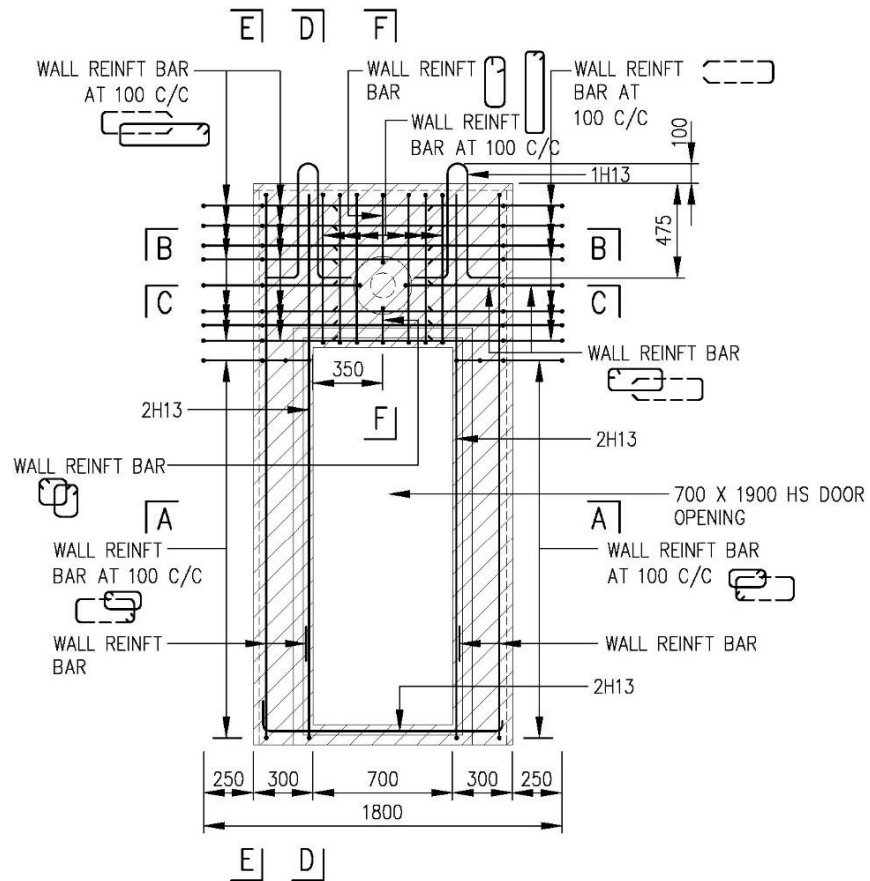
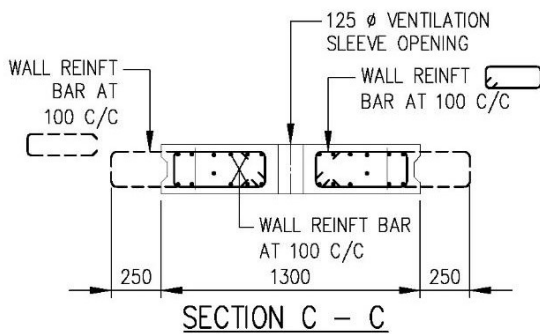
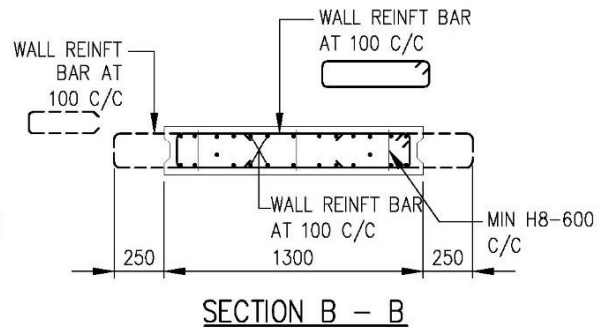
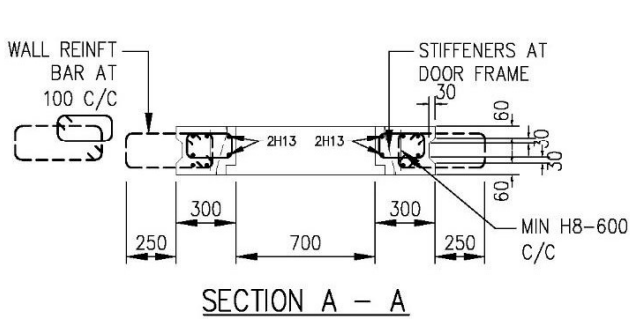

FIGURE 3.5.5(a) PLAN OF HS WITH PRE-CAST HS DOOR FRAME PANEL (TYPE 1)



ELEVATION



NOTE:

1. WALL REINFORCEMENT REFER TO TABLE 3.4.2.1(a) FOR LANDED DEVELOPMENT OR TABLE 3.4.2.1(b) FOR NON-LANDED DEVELOPMENT

FIGURE 3.5.5(b) DETAILS AND SECTIONS OF PRE-CAST HS DOOR FRAME PANEL WITH VENTILATION SLEEVE ABOVE IT (TYPE 1)

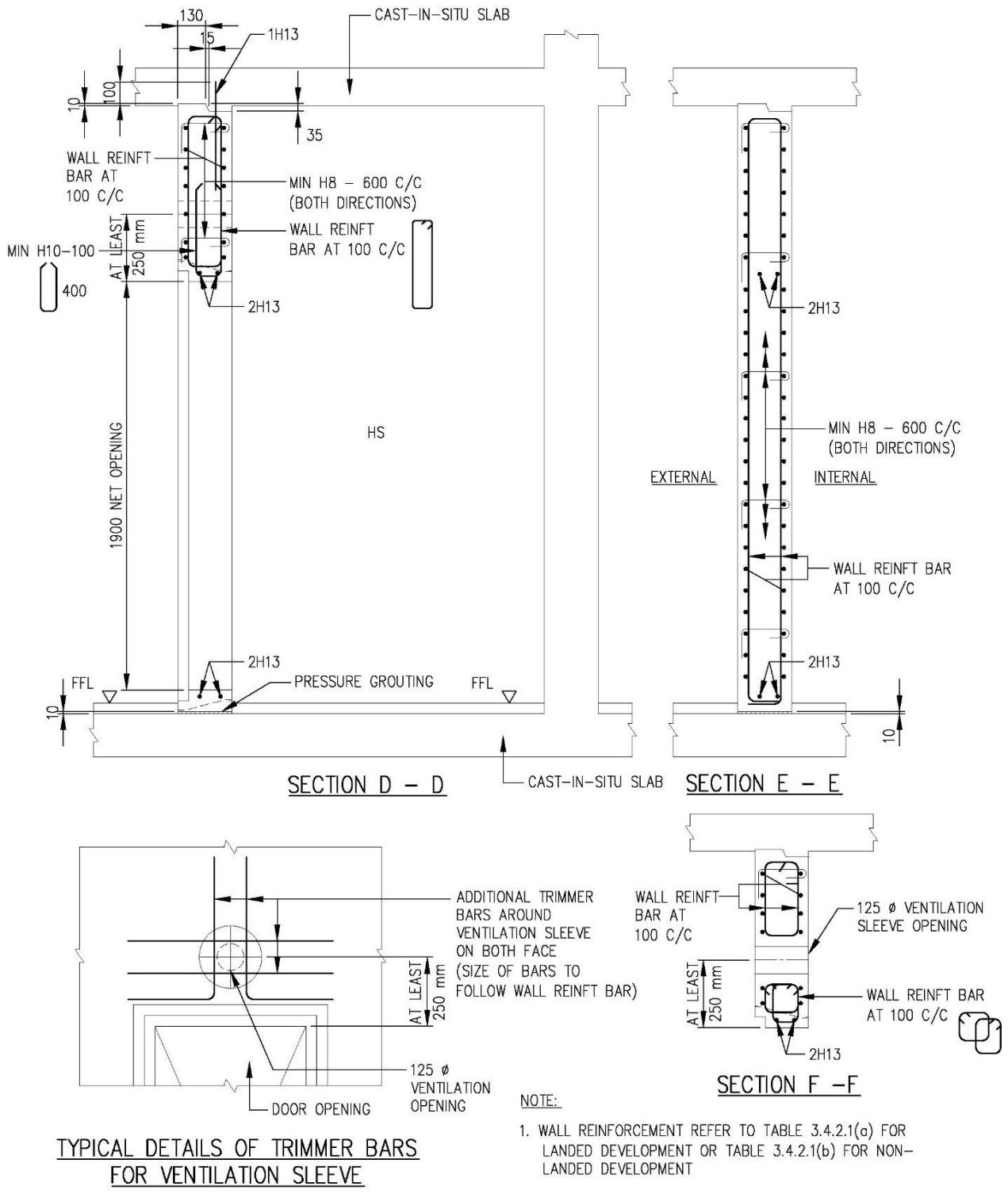
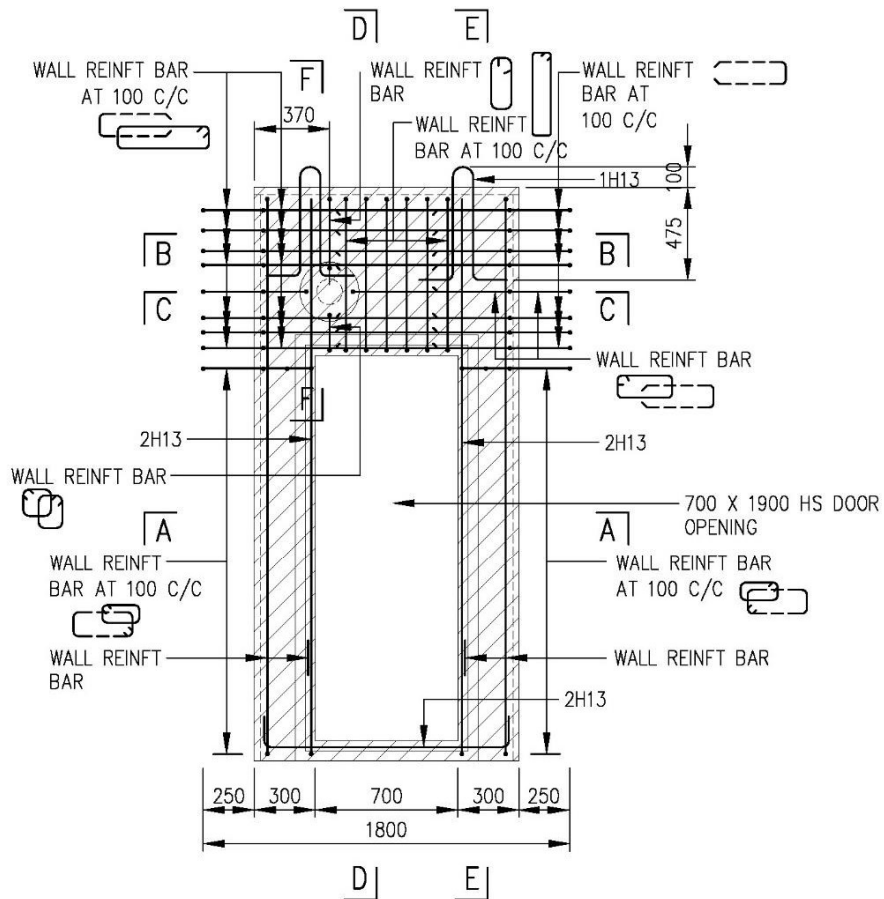
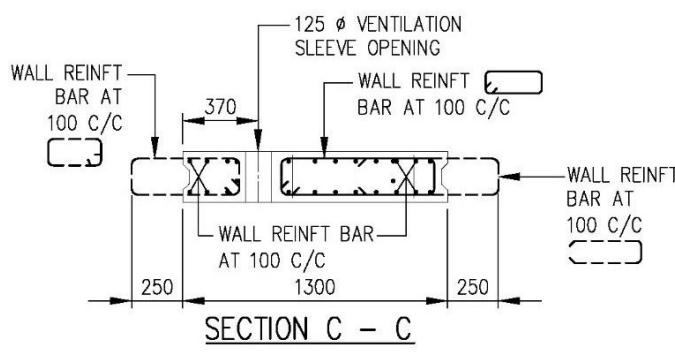
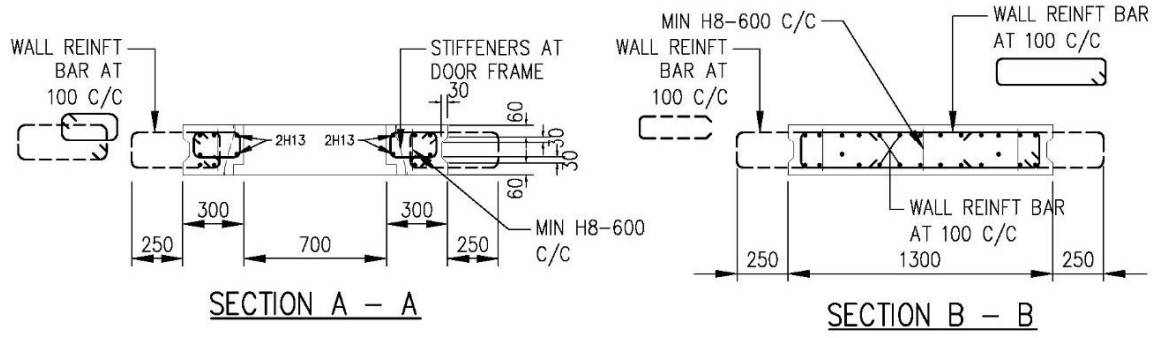

FIGURE 3.5.5(c) SECTIONS OF PRE-CAST HS DOOR FRAME PANEL WITH VENTILATION SLEEVE ABOVE IT (TYPE 1)



ELEVATION



NOTE:
 1. WALL REINFORCEMENT REFER TO TABLE 3.4.2.1(a) FOR LANDED DEVELOPMENT OR TABLE 3.4.2.1(b) FOR NON-LANDED DEVELOPMENT

FIGURE 3.5.5(d) DETAILS AND SECTIONS OF PRE-CAST HS DOOR FRAME PANEL WITH VENTILATION SLEEVE AT ITS SIDE (TYPE 1)

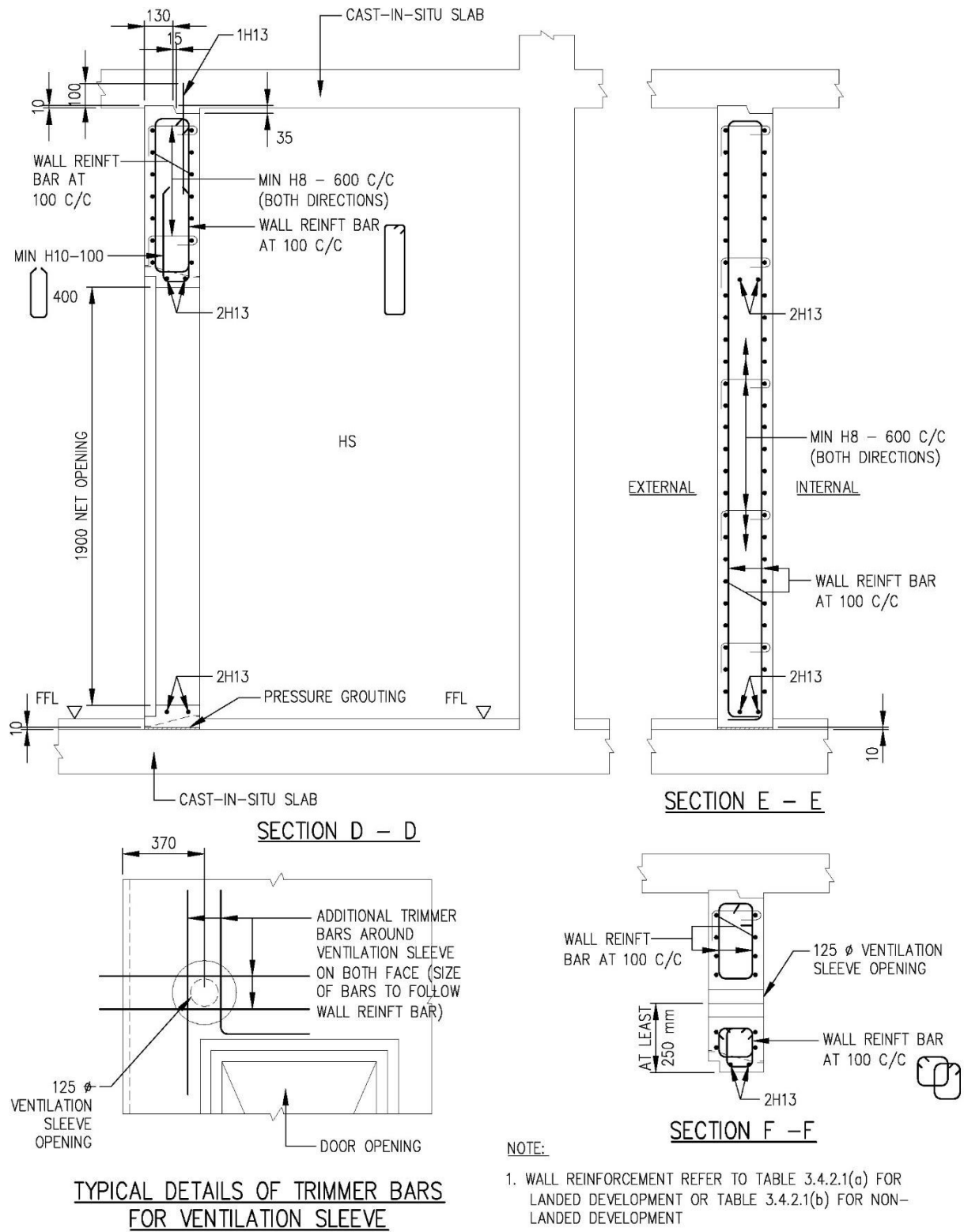
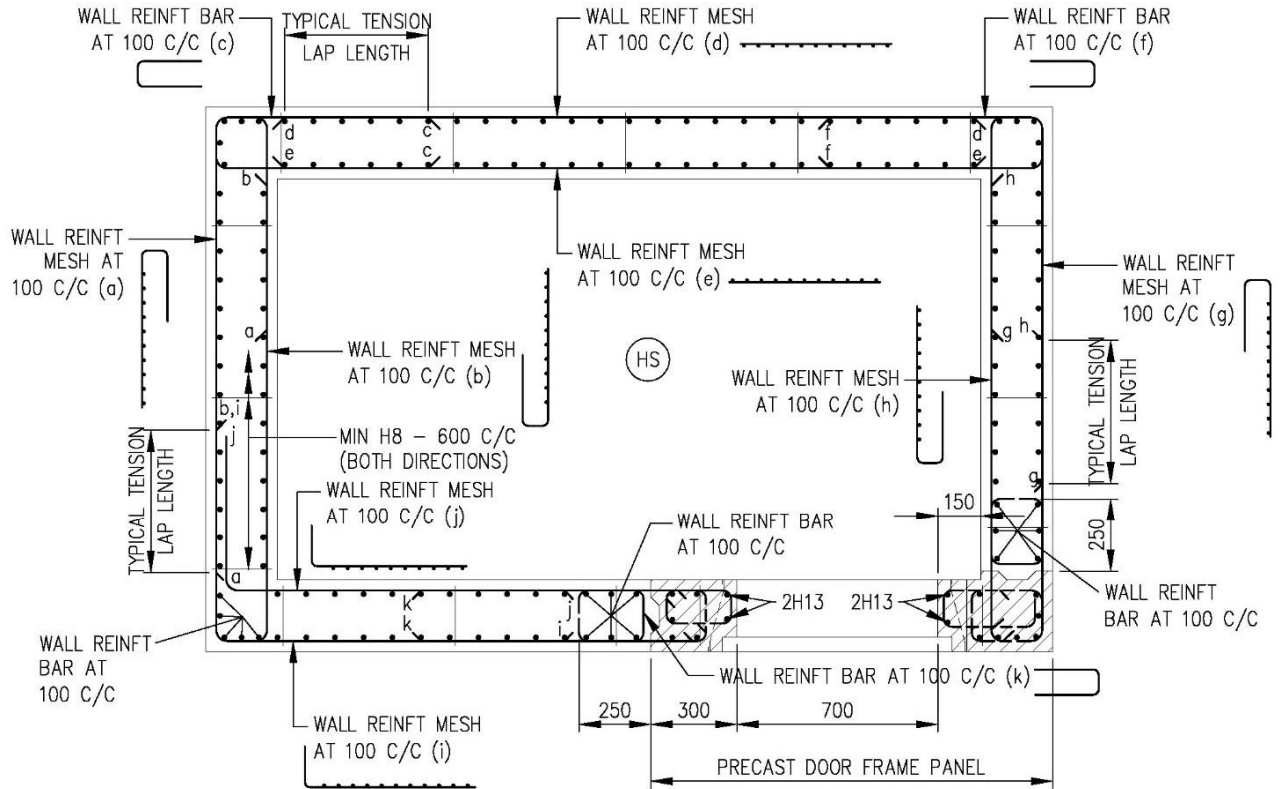

FIGURE 3.5.5(e) SECTIONS OF PRE-CAST HS DOOR FRAME PANEL WITH VENTILATION SLEEVE AT ITS SIDE (TYPE 1)



NOTE:

1. WALL REINFORCEMENT REFER TO TABLE 3.4.2.1(a) FOR LANDED DEVELOPMENT OR TABLE 3.4.2.1(b) FOR NON-LANDED DEVELOPMENT

FIGURE 3.5.5(f) PLAN OF HS WITH PRE-CAST HS DOOR FRAME PANEL (TYPE 2)

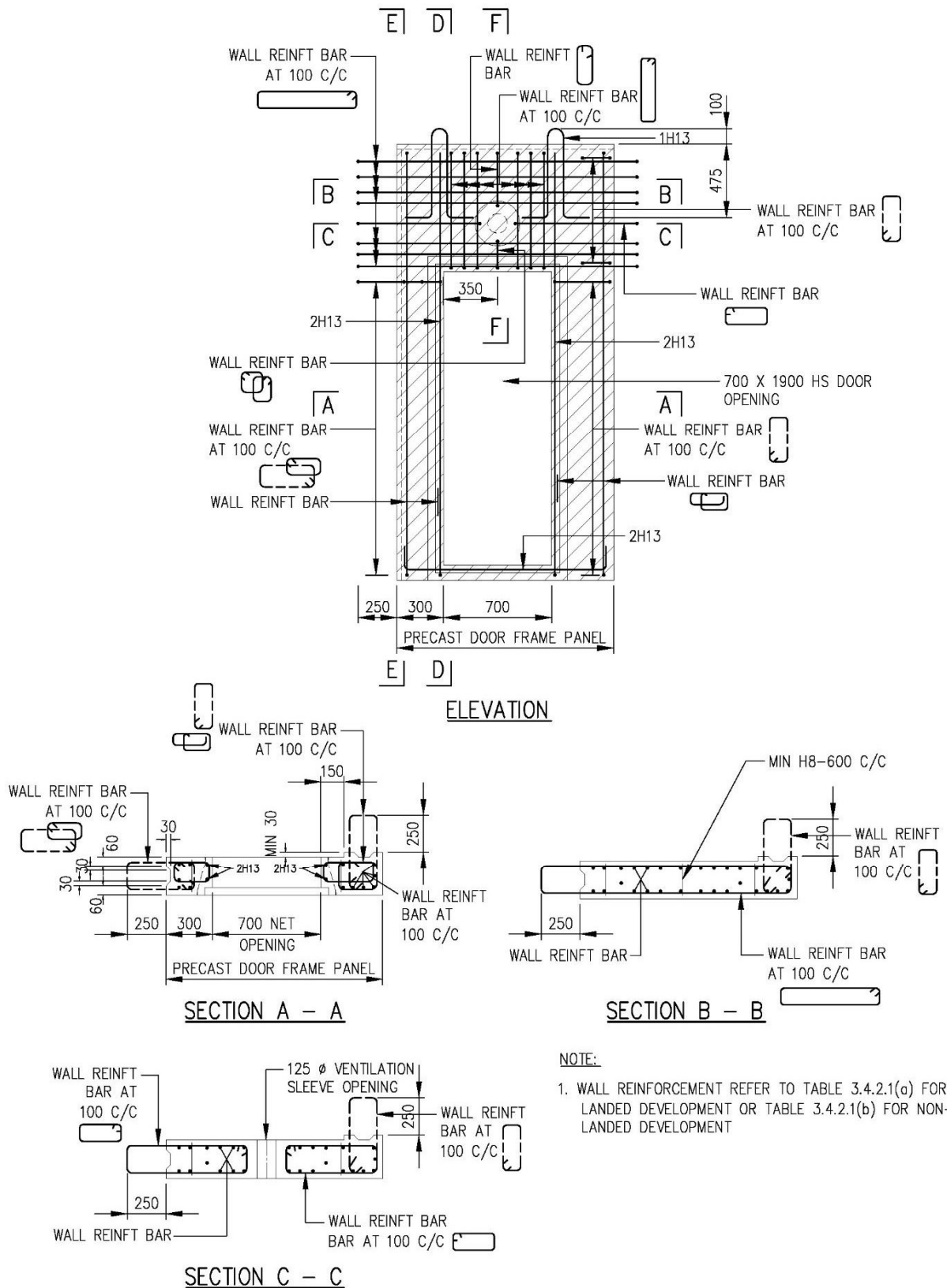

FIGURE 3.5.5(g) DETAILS AND SECTIONS OF PRE-CAST HS DOOR FRAME PANEL WITH VENTILATION SLEEVE ABOVE IT (TYPE 2)

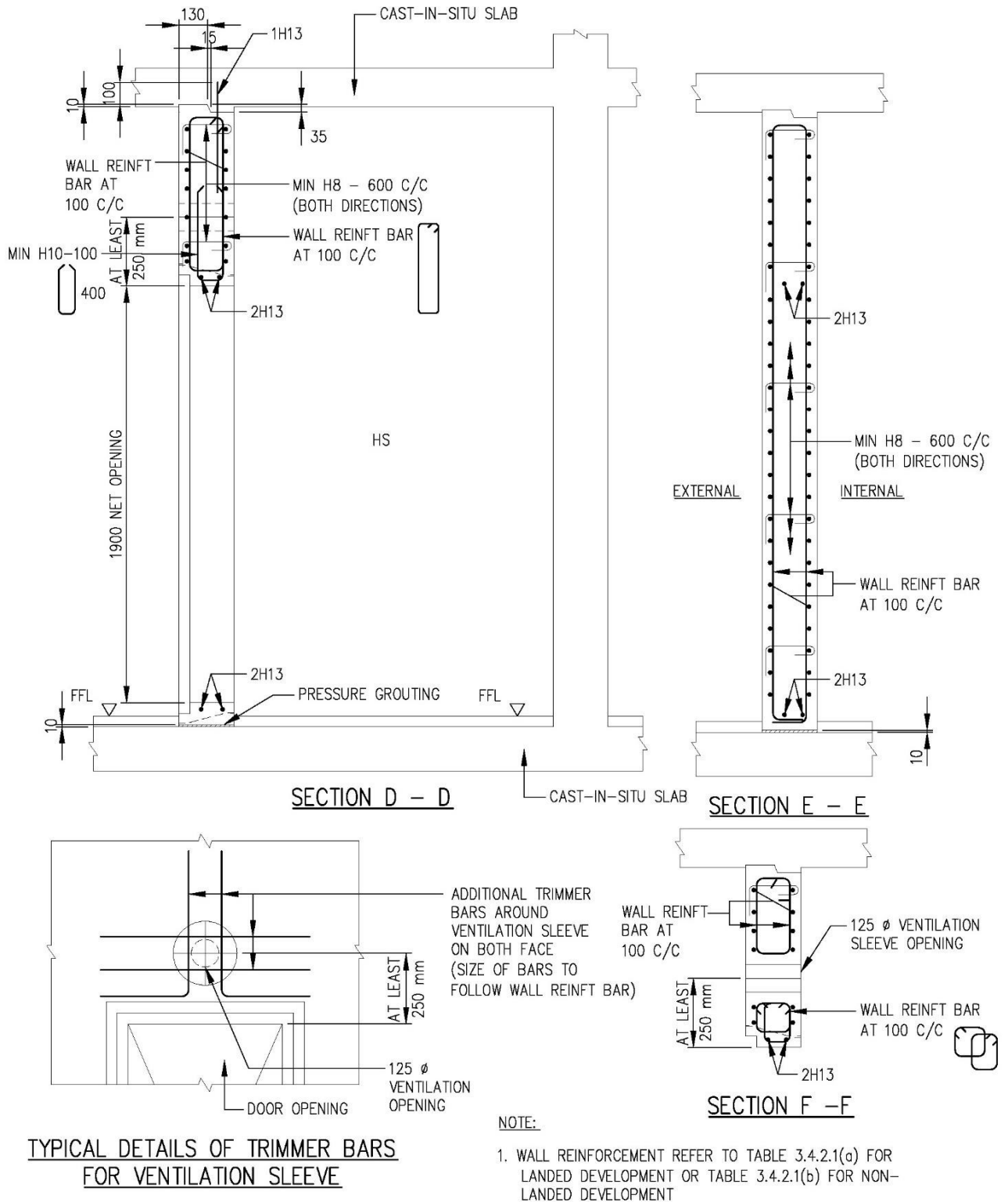

FIGURE 3.5.5(h) SECTIONS OF PRE-CAST HS DOOR FRAME PANEL WITH VENTILATION SLEEVE ABOVE IT (TYPE 2)

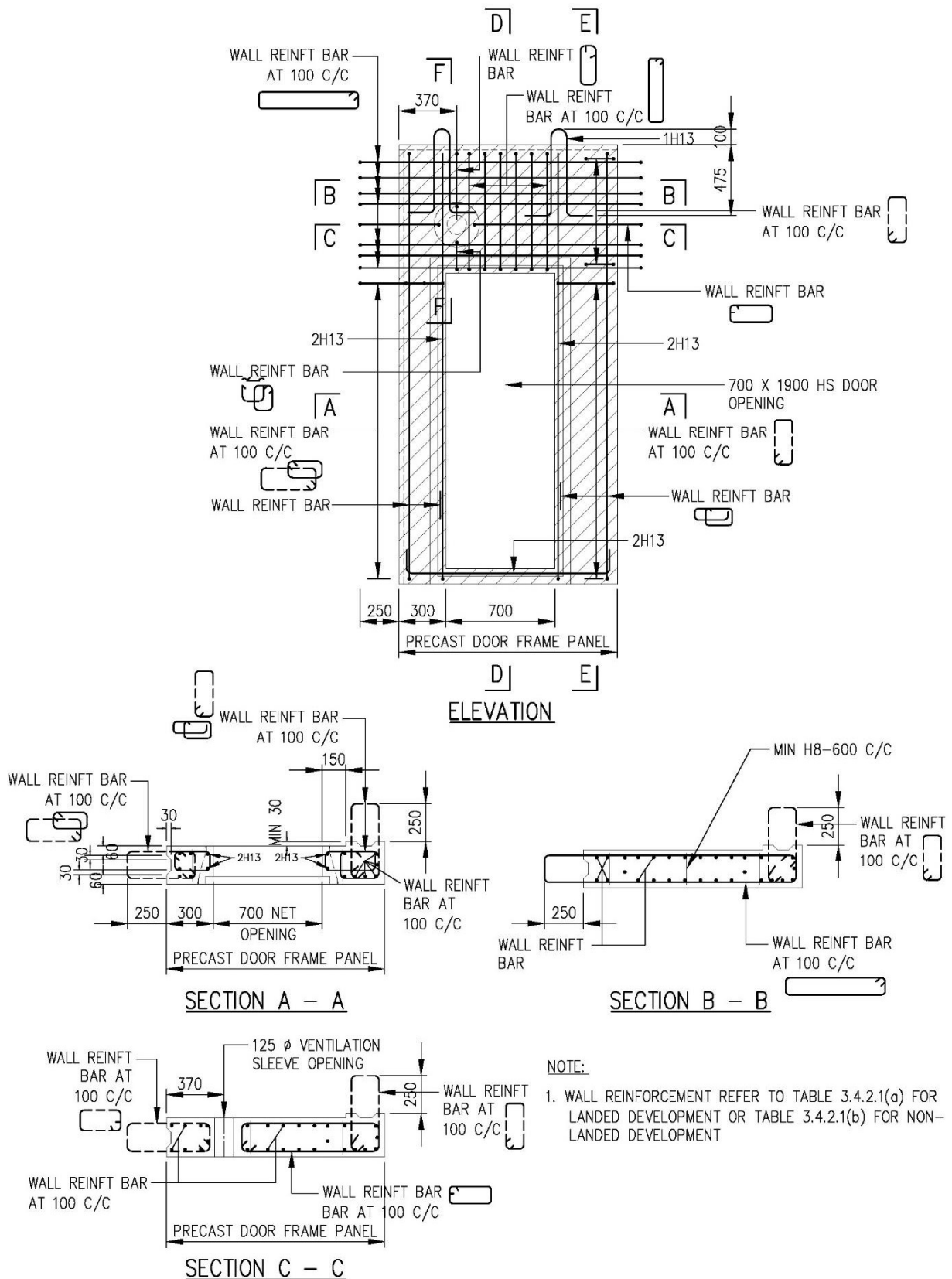

FIGURE 3.5.5(i) DETAILS AND SECTIONS OF PRE-CAST HS DOOR FRAME PANEL WITH VENTILATION SLEEVE AT ITS SIDE (TYPE 2)

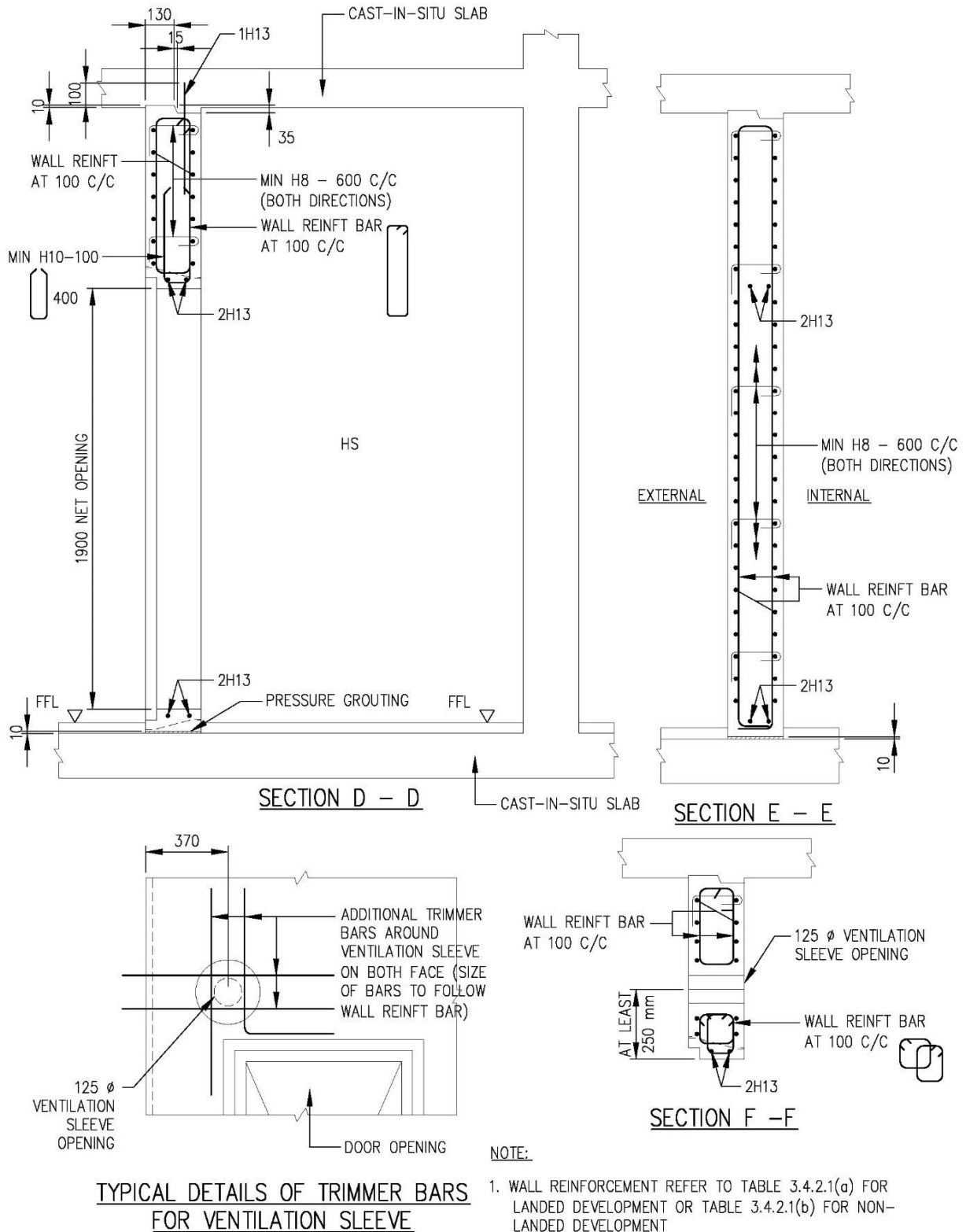

FIGURE 3.5.5(i) SECTIONS OF PRE-CAST HS DOOR FRAME PANEL WITH VENTILATION SLEEVE AT ITS SIDE (TYPE 2)

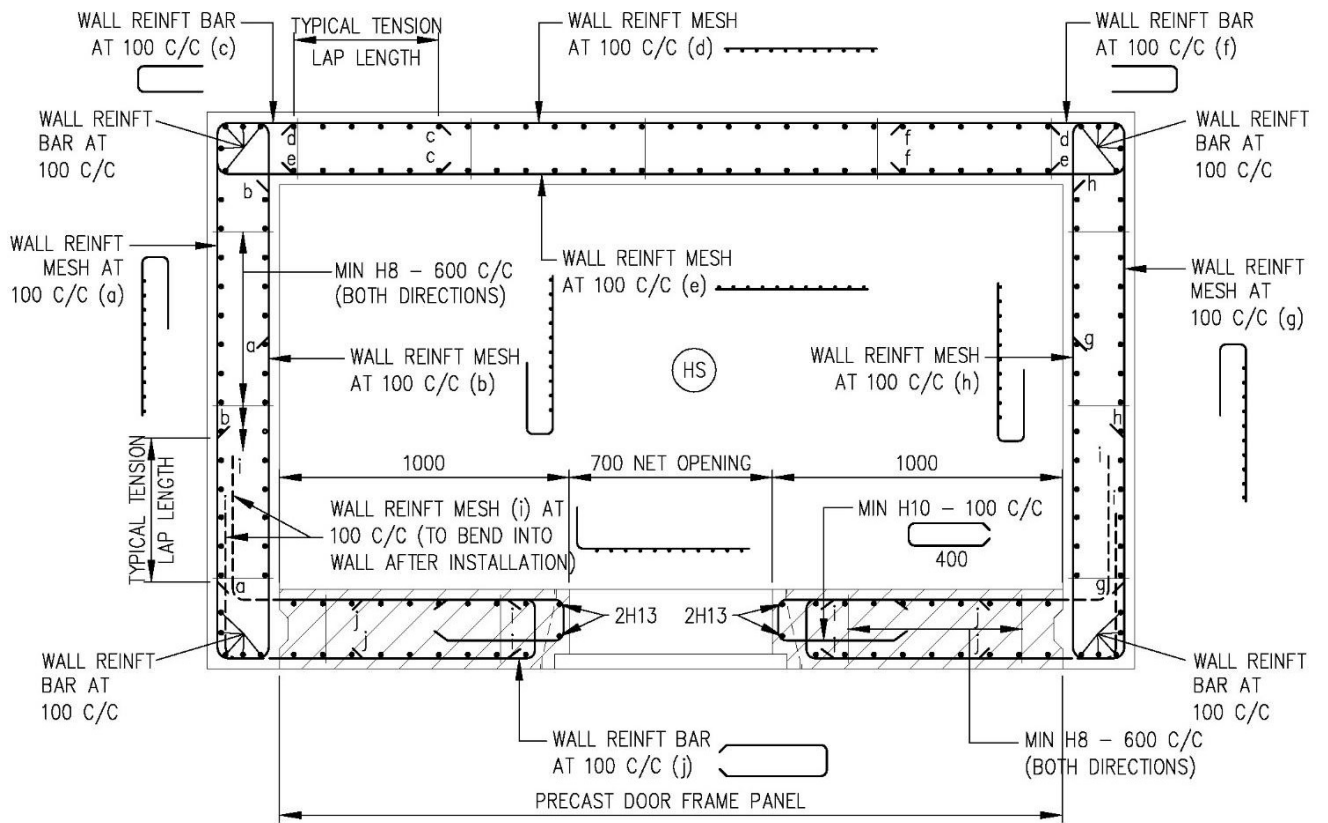
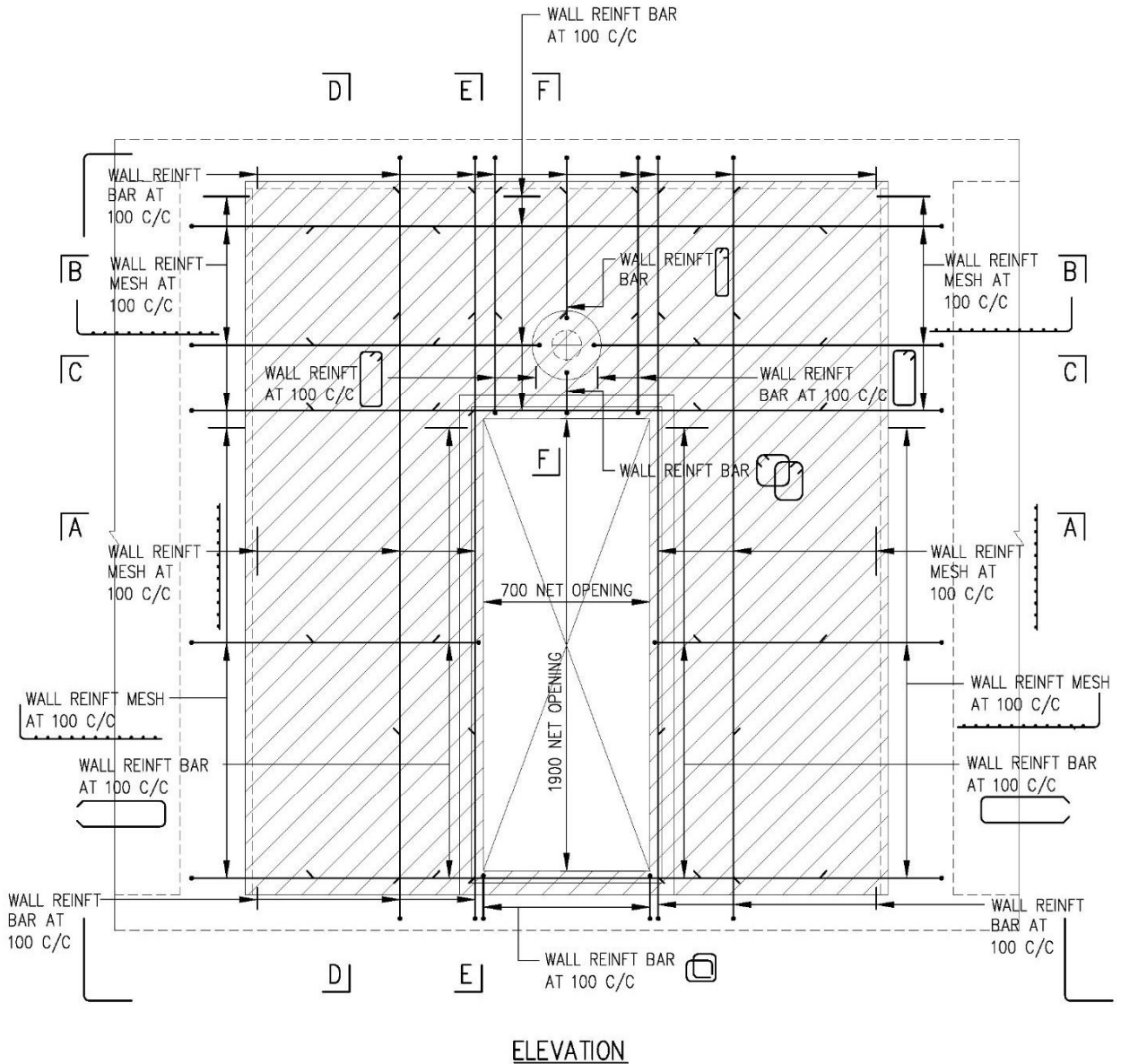

FIGURE 3.5.5(k) PLAN OF HS WITH PRE-CAST HS DOOR FRAME PANEL (TYPE 3)



NOTE:

1. WALL REINFORCEMENT REFER TO TABLE 3.4.2.1(a) FOR LANDED DEVELOPMENT OR TABLE 3.4.2.1(b) FOR NON-LANDED DEVELOPMENT

FIGURE 3.5.5(i) DETAILS OF PRE-CAST HS DOOR FRAME PANEL (TYPE 3)

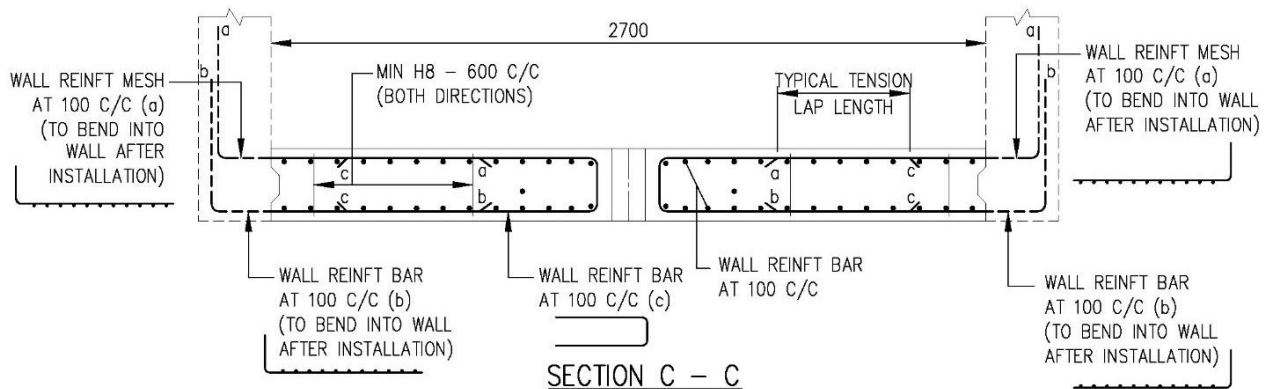
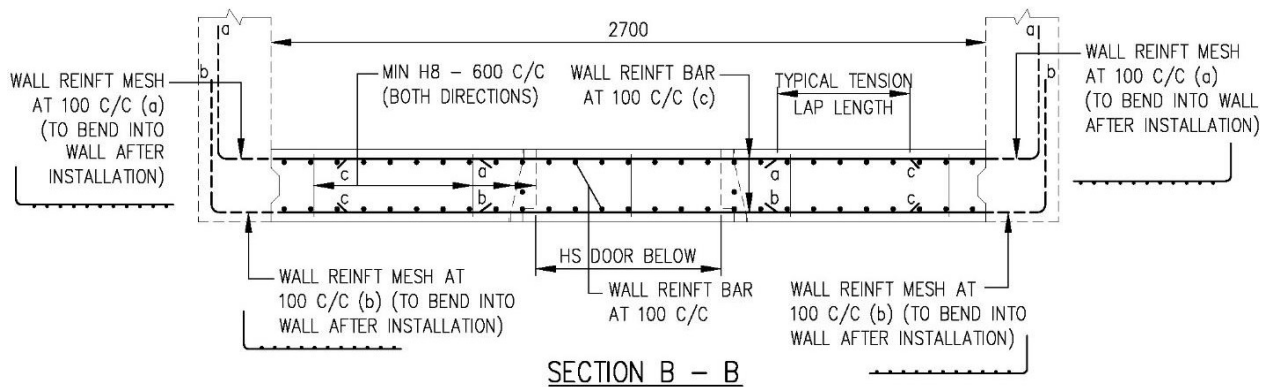
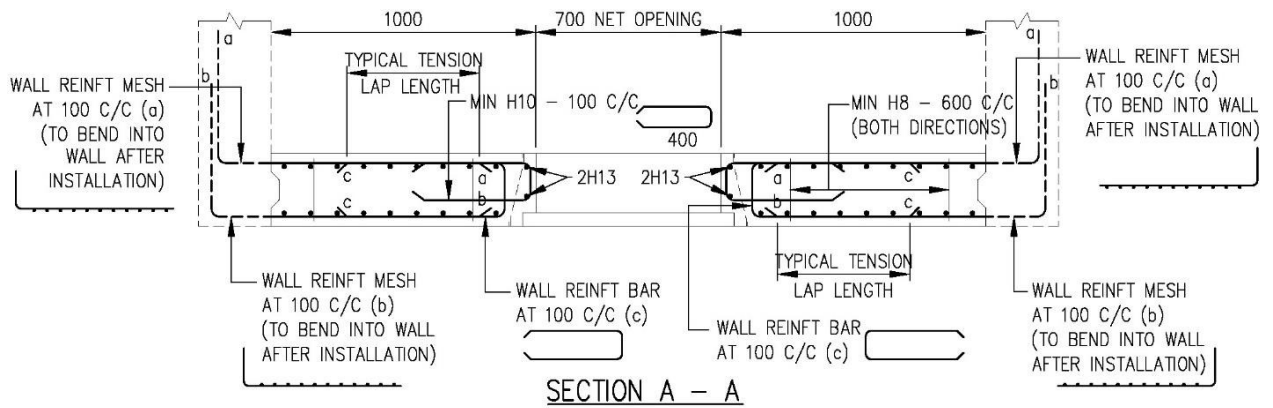

NOTE:

1. WALL REINFORCEMENT REFER TO TABLE 3.4.2.1(a) FOR LANDED DEVELOPMENT OR TABLE 3.4.2.1(b) FOR NON-LANDED DEVELOPMENT

FIGURE 3.5.5(m) SECTIONS OF PRE-CAST HS DOOR FRAME PANEL (TYPE 3)

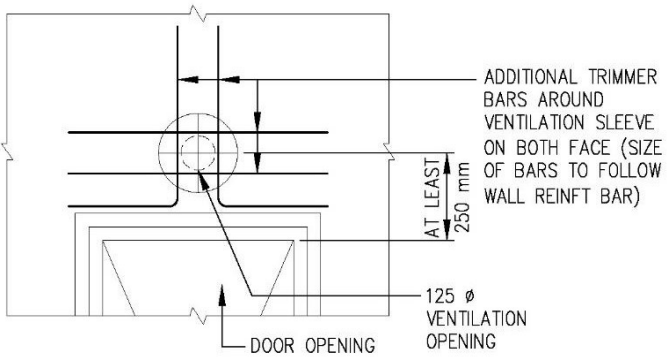
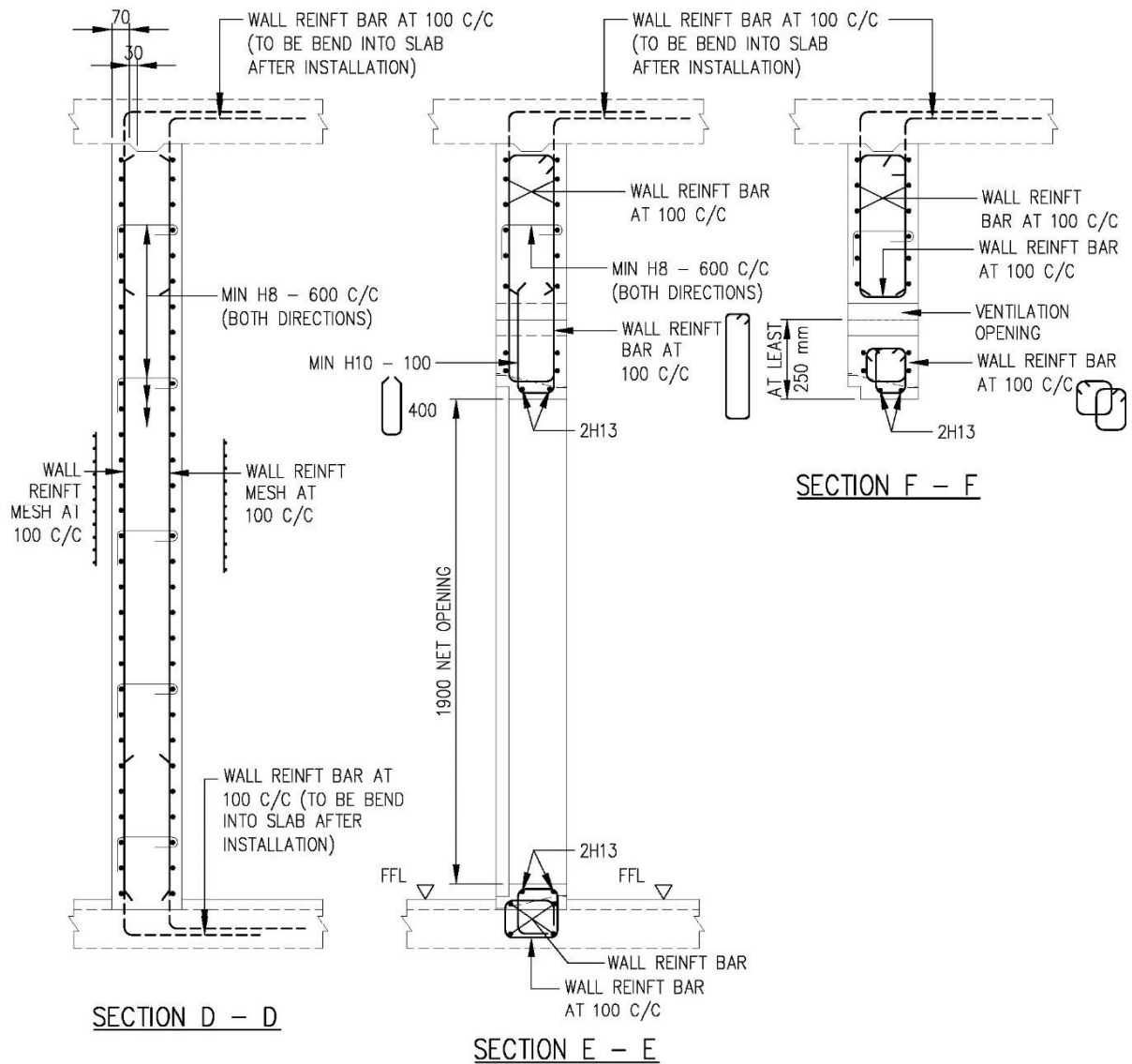

NOTE:
 1. WALL REINFORCEMENT REFER TO TABLE 3.4.2.1(a) FOR LANDED DEVELOPMENT OR TABLE 3.4.2.1(b) FOR NON-LANDED DEVELOPMENT

TYPICAL DETAILS OF TRIMMER BARS FOR VENTILATION SLEEVE

FIGURE 3.5.5(m) SECTIONS OF PRE-CAST HS DOOR FRAME PANEL (TYPE 3)

TABLE 3.5.6(a): DIMENSION OF PRECAST HOLLOW CORES HS

Precast Hollow Core Household Shelter	Minimum Dimension (mm)	Maximum Dimension (mm)
Length of Hollow Core (a*)	200	500
Width of Hollow Core (b^)	150	200
Distance between the nearest hollow core and internal wall (c1^ / c3^)	25	50
Distance between two hollow cores (c2)	100	
Distance between the nearest hollow core and edge of door frame (d1^)	250	300
Distance between the nearest hollow core and edge of door frame with internal electrical fixture between them (d2^)	425	500
Distance between the nearest hollow core and edge of door frame for door on short wall of dimension 1200mm and 1350mm (d3#)	150	300
Distance between the nearest hollow core and centre of ventilation sleeve (e^)	150	200
Distance between the nearest hollow core and edge of a C-shaped HS wall (f^)	250	350

*Dimensions with increment of 100mm

#Dimensions with increment of 50mm

^Dimensions with increment of 25mm

TABLE 3.5.6(b): HS WALL THICKNESS AND SIZES OF HOLLOW CORES

HS Wall Thickness, t (mm)	Size of Hollow Core	
	b (mm)	a (mm)
250	150	200
		300
		400
		500
275	175	200
		300
		400
		500
300	200	200
		300
		400
		500

TABLE 3.5.6(c): MINIMUM REINFORCEMENT BARS IN HOLLOW CORES

HS Clear Height (mm)	Size of Hollow Core		Minimum Reinforcement Bars in Hollow Cores	Minimum Links for Reinforcement Bars in Hollow Cores
	b (mm)	a (mm)		
2400 < Ht ≤ 3000	150/175/200	200	4H20	H8 - 250
		300	6H16	H8 - 250
		400	8H16	H8 - 250
		500	10H16	H8 - 250
3000 < Ht ≤ 3900	150/175/200	200	4H25	H8 - 250
		300	6H20	H8 - 250
		400	8H20	H8 - 250
		500	10H20	H8 - 250

Notes

If larger size of reinforcement bars are required in the hollow cores, the number of such reinforcement bars shall remain the same as stipulated in the table above.

TABLE 3.5.6(d): MINIMUM THICKNESS OF SLAB AND REINFORCED CONCRETE TOPPING

Floor Type	Slab Thickness (mm)	Precast Plank Thickness (mm)	Reinforced Concrete Topping Thickness (mm)
HS Roof Slab	300	70	230
HS Intermediate Slab	175	70	105

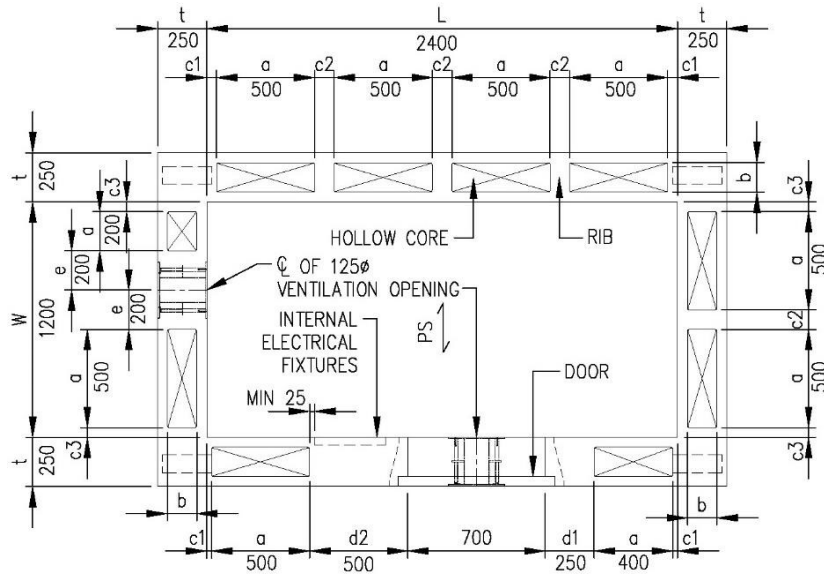

FIGURE 3.5.6.1(a) PRECAST HS WITH HS DOOR ON LONGER WALL AND ONE OF VENTILATION SLEEVE ABOVE THE DOOR (TYPE 1)

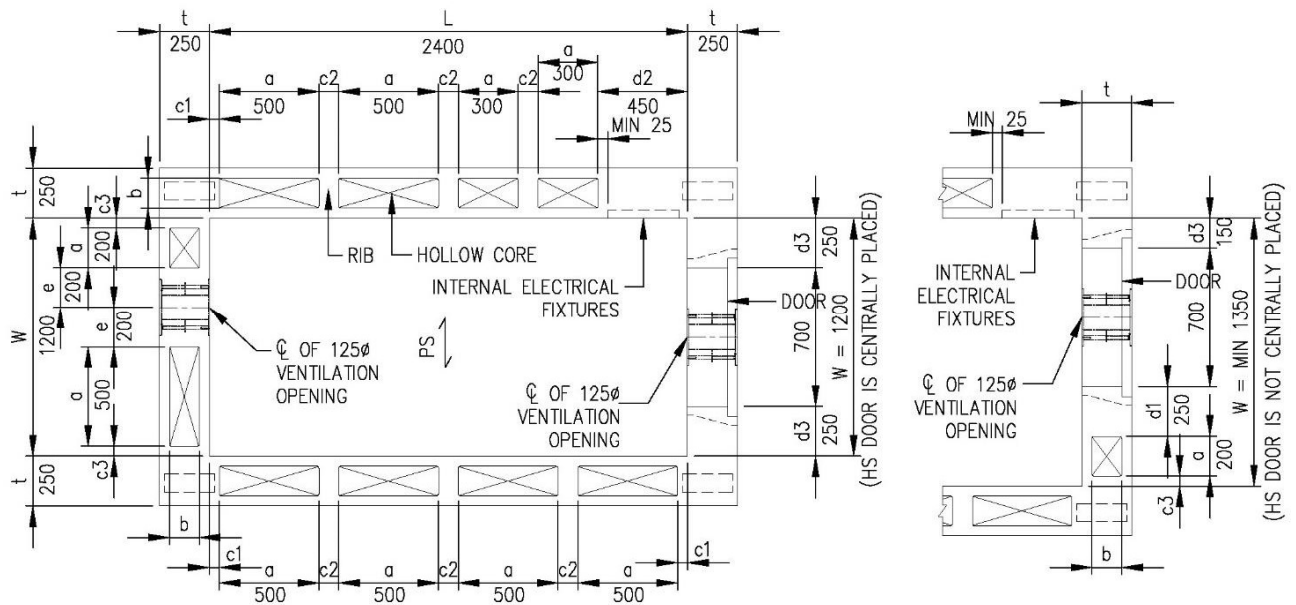

FIGURE 3.5.6.1(b) PRECAST HS WITH HS DOOR ON SHORTER WALL AND ONE OF VENTILATION SLEEVE ABOVE THE DOOR (TYPE 2)

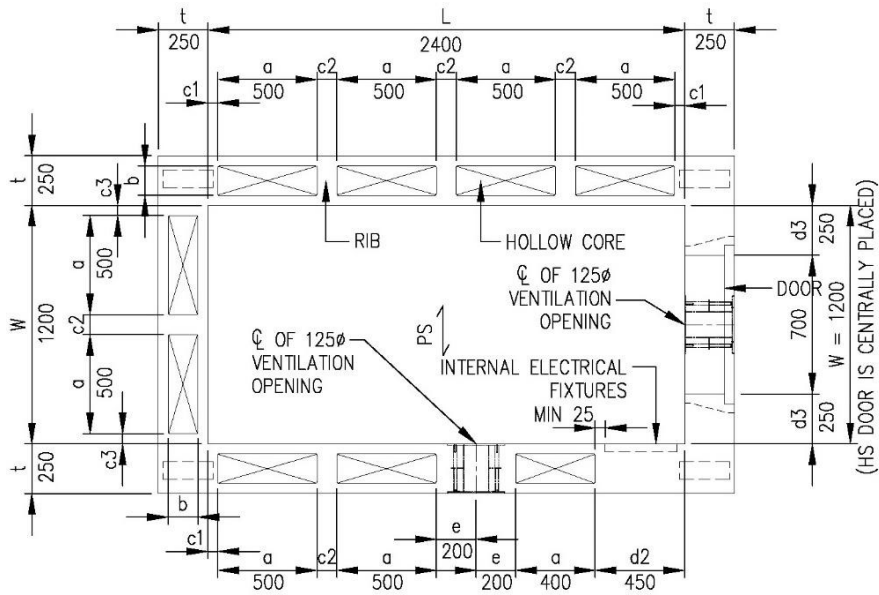

FIGURE 3.5.6.1(c) PRECAST HS SHOWING VENTILATION SLEEVE AND INTERNAL ELECTRICAL FIXTURES ON THE SAME WALL (TYPE 3)

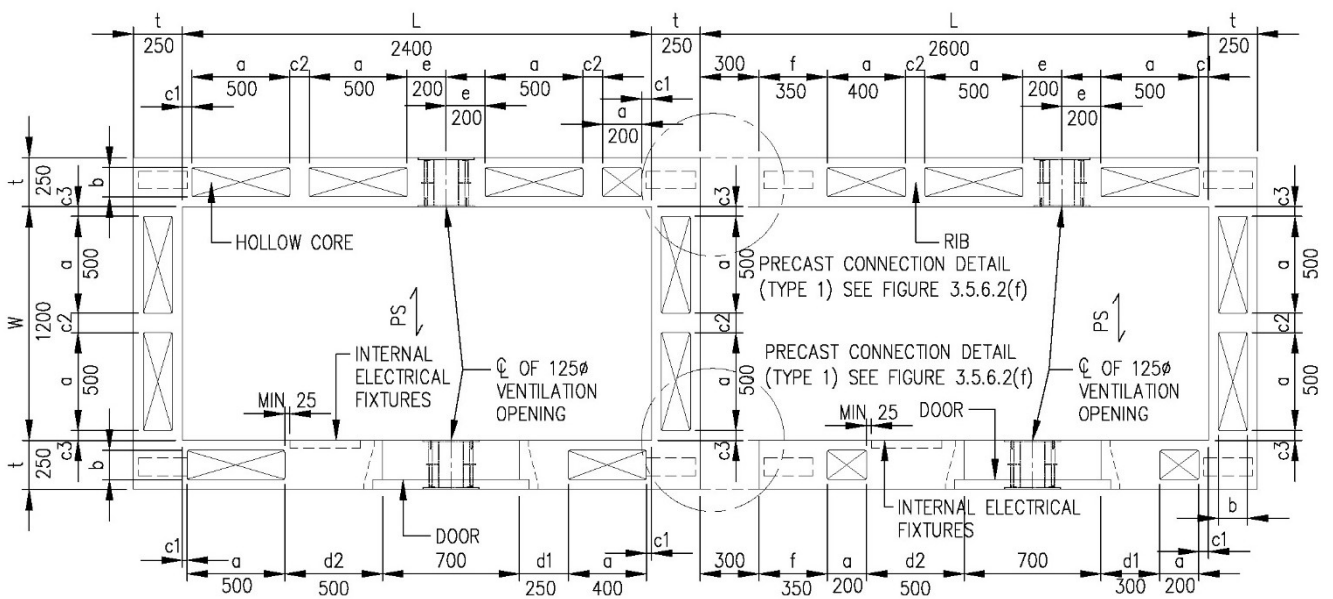

FIGURE 3.5.6.1(d) PRECAST HS AND C-SHAPED PRECAST HS CONNECTED AT THE SHORTER WALL AND WITH HS DOORS ON LONGER WALLS (TYPE 4)

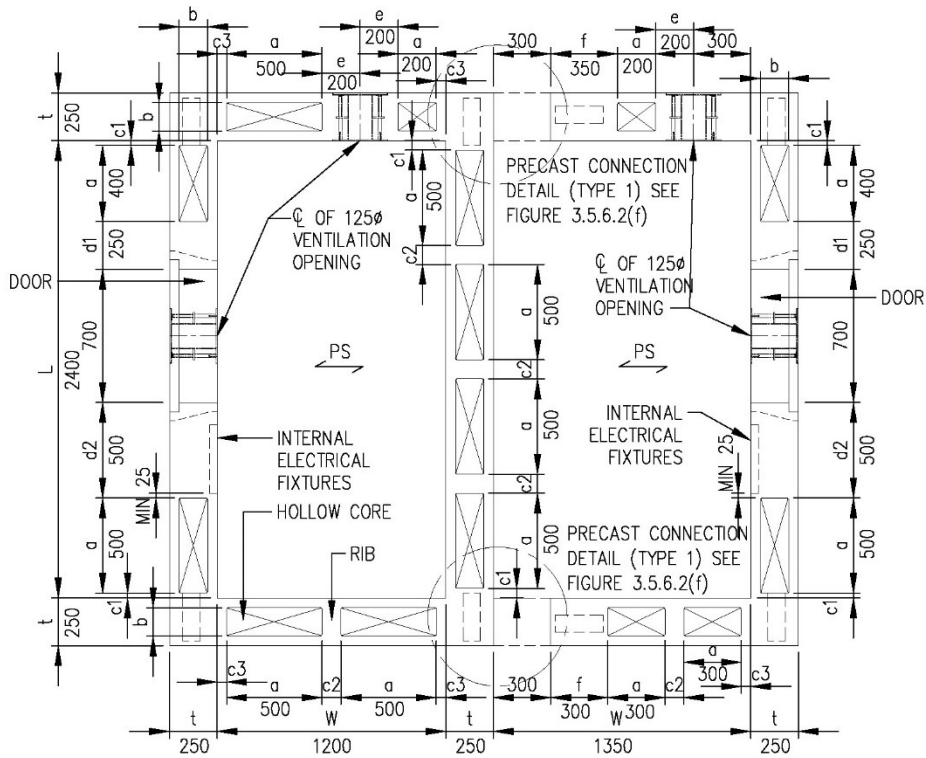

FIGURE 3.5.6.1(e) PRECAST HS AND C-SHAPED PRECAST HS CONNECTED AT THE LONGER WALL AND WITH HS DOOR ON LONGER WALLS (TYPE 5)

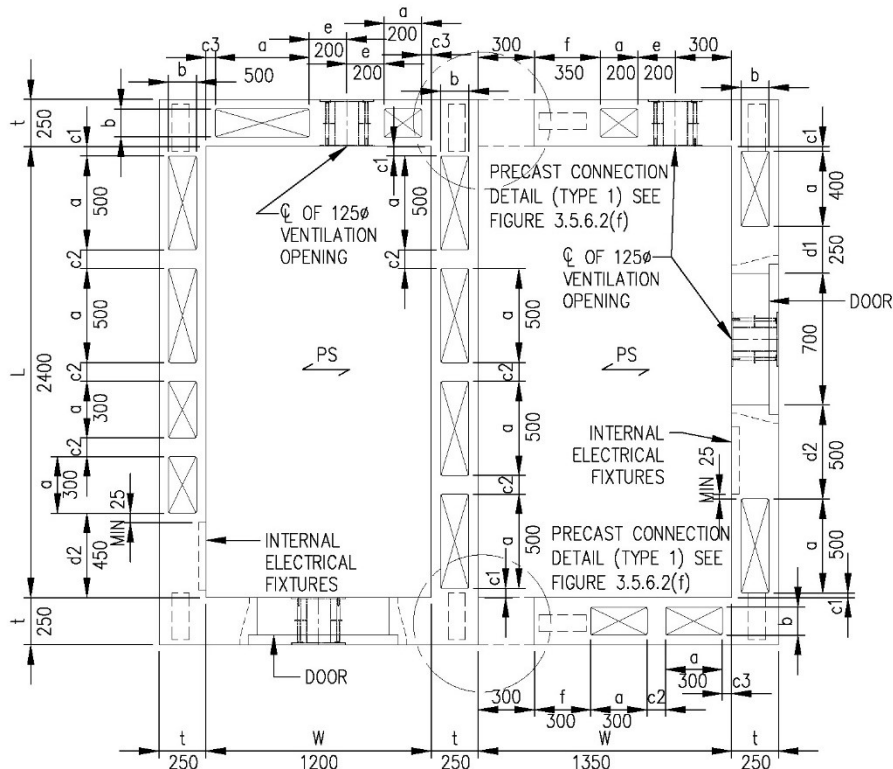

FIGURE 3.5.6.1(f) PRECAST HS AND C-SHAPED PRECAST HS CONNECTED AT THE LONGER WALL AND WITH HS DOOR EACH ON LONGER WALL AND SHORTER WALL (TYPE 5A)

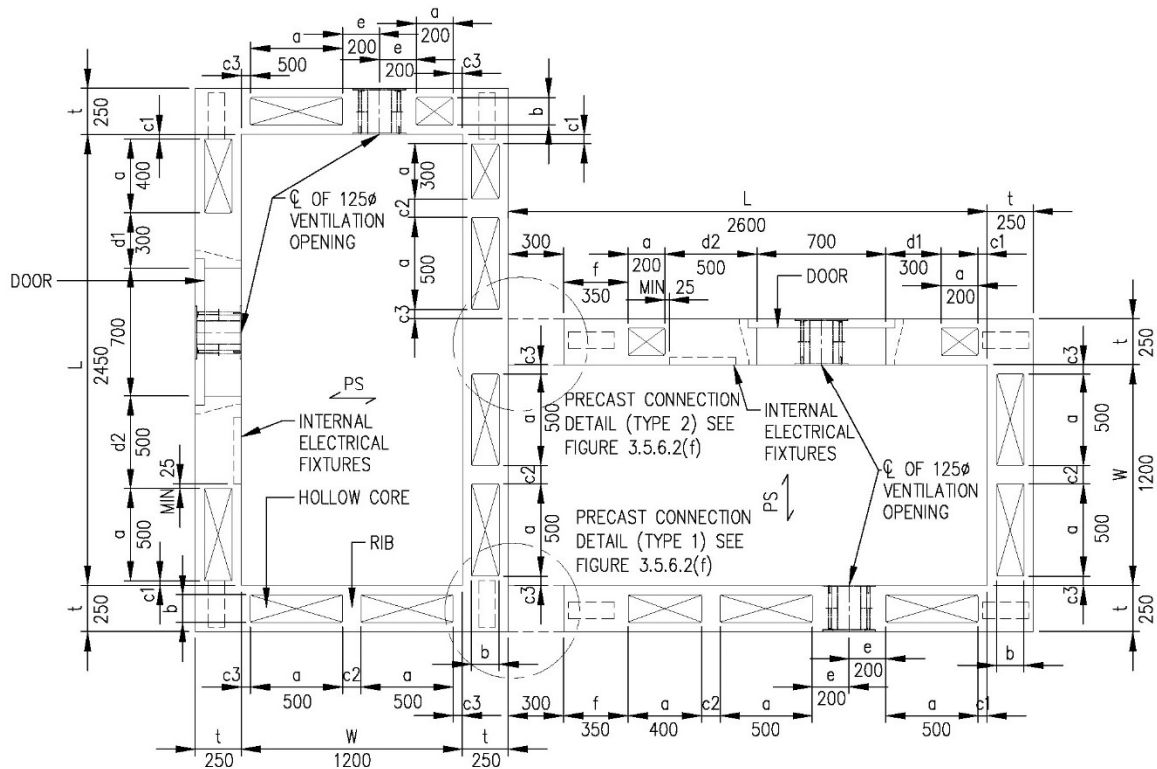

FIGURE 3.5.6.1(g) PRECAST HS AND C-SHAPED PRECAST HS WITH CONNECTION BETWEEN LONGER AND SHORTER WALLS RESPECTIVELY AND WITH HS DOORS ON LONGER WALL (TYPE 6)

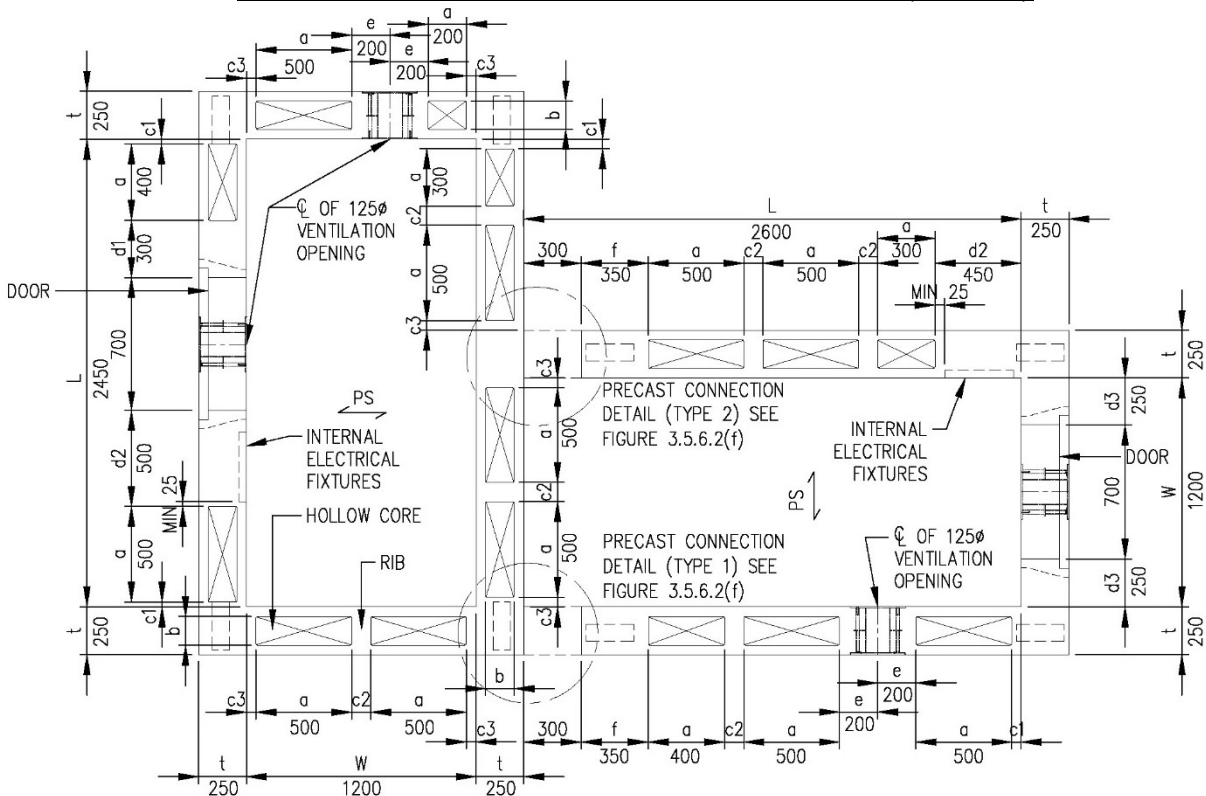

FIGURE 3.5.6.1(h) PRECAST HS AND C-SHAPED PRECAST HS WITH CONNECTION BETWEEN LONGER AND SHORTER WALLS RESPECTIVELY AND WITH HS DOOR EACH ON LONGER WALL AND SHORTER WALL (TYPE 6A)

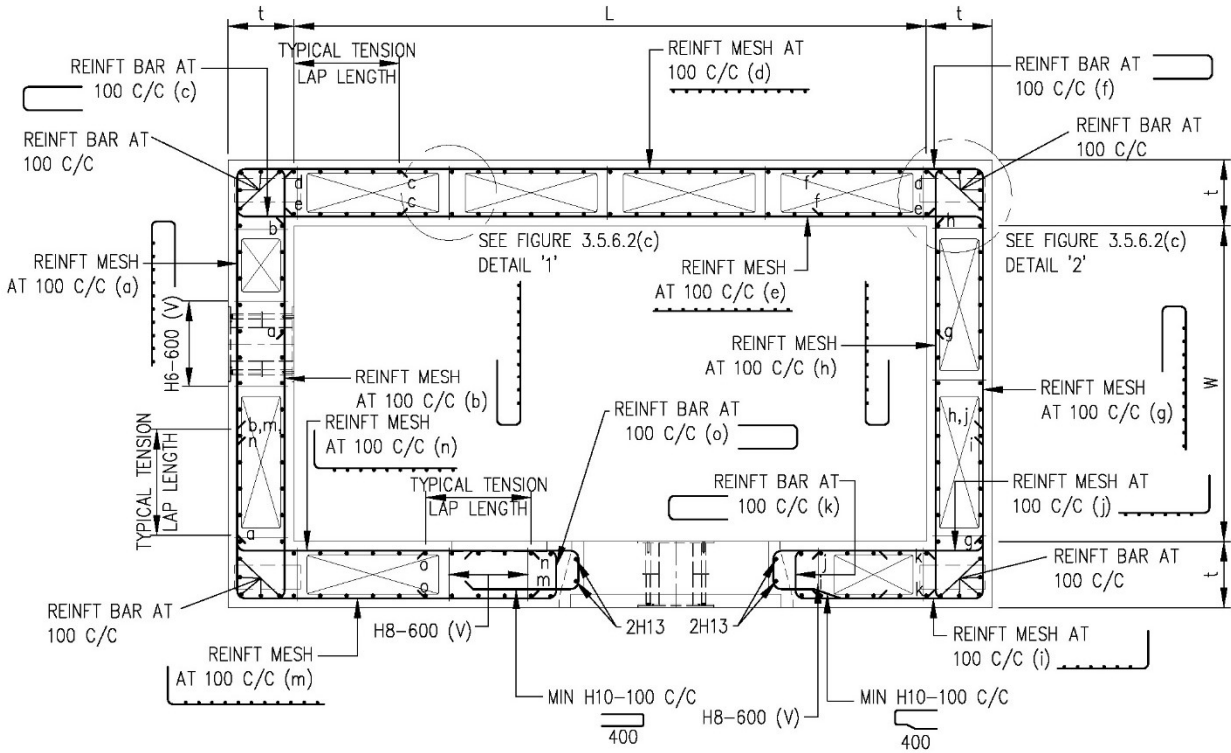

FIGURE 3.5.6.2(a) REINFORCEMENT BAR DETAILS OF WALL, RIB AND BLAST DOOR ON LONG WALL OF PRECAST HS

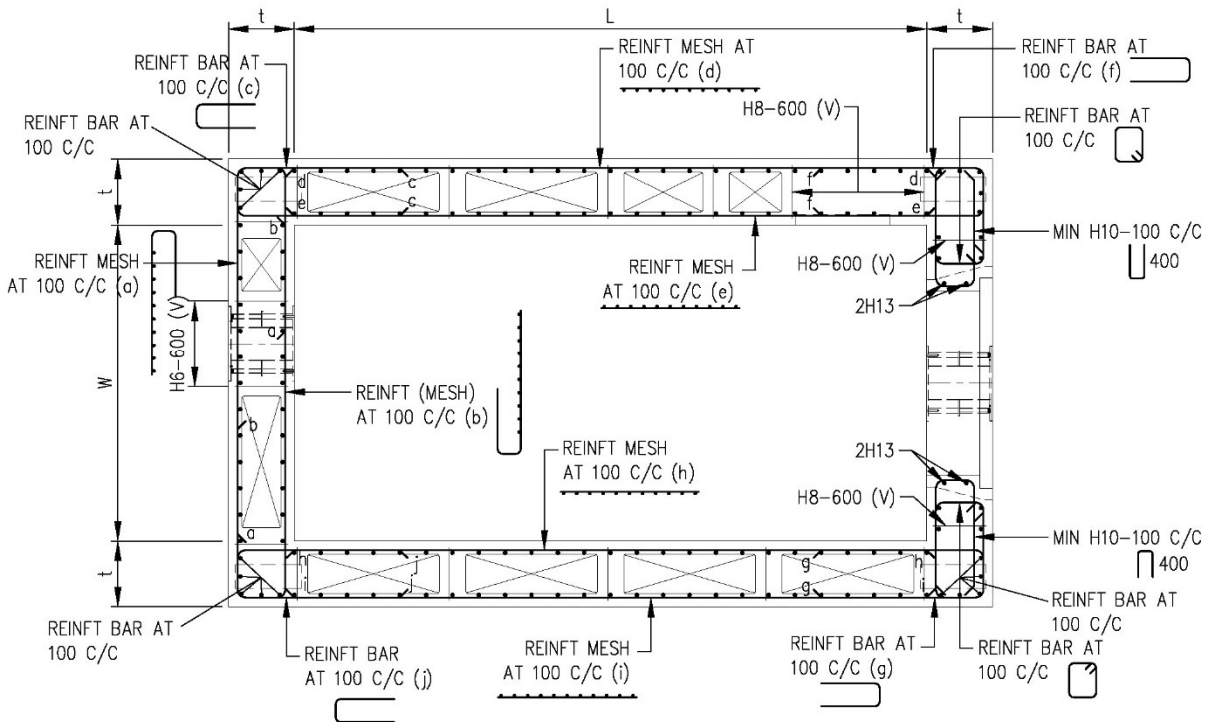
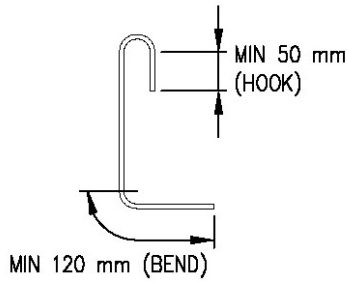

FIGURE 3.5.6.2(b) REINFORCEMENT BAR DETAILS OF WALL, RIB AND BLAST DOOR ON SHORT WALL OF PRECAST HS



MINIMUM HOOK AND BEND FOR SHEAR LINKS (H8)

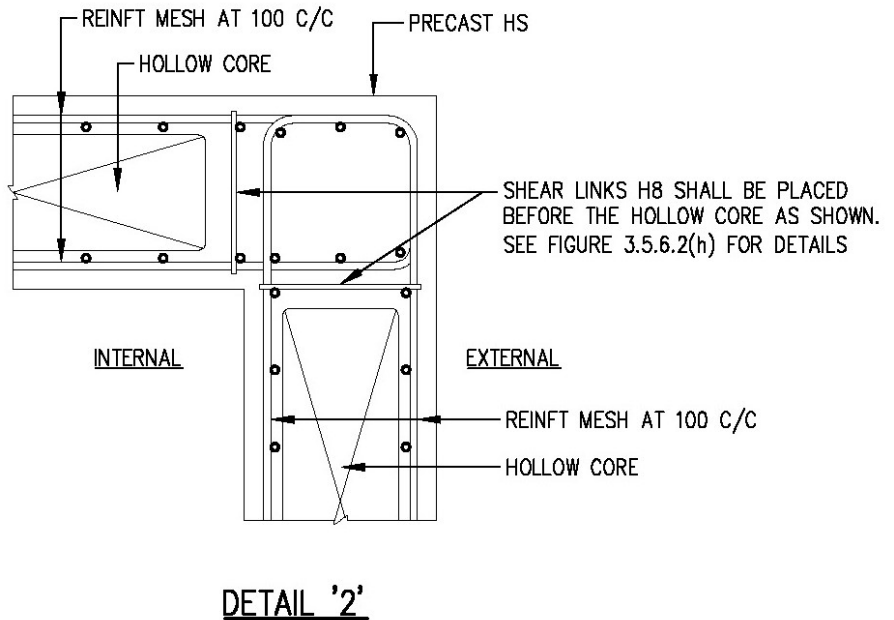
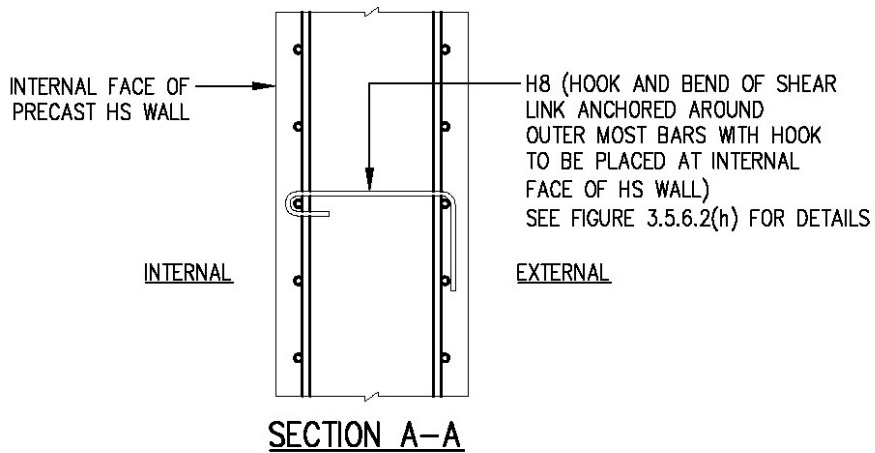
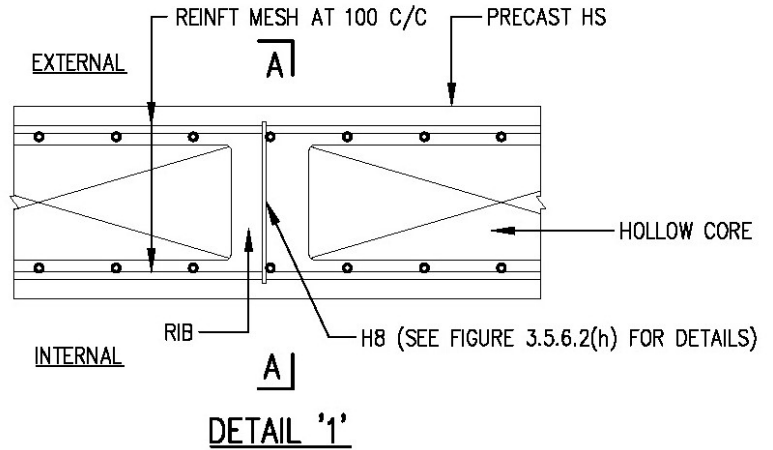

FIGURE 3.5.6.2(c) PLAN AND SECTION OF RIB WITH SHEAR LINKS

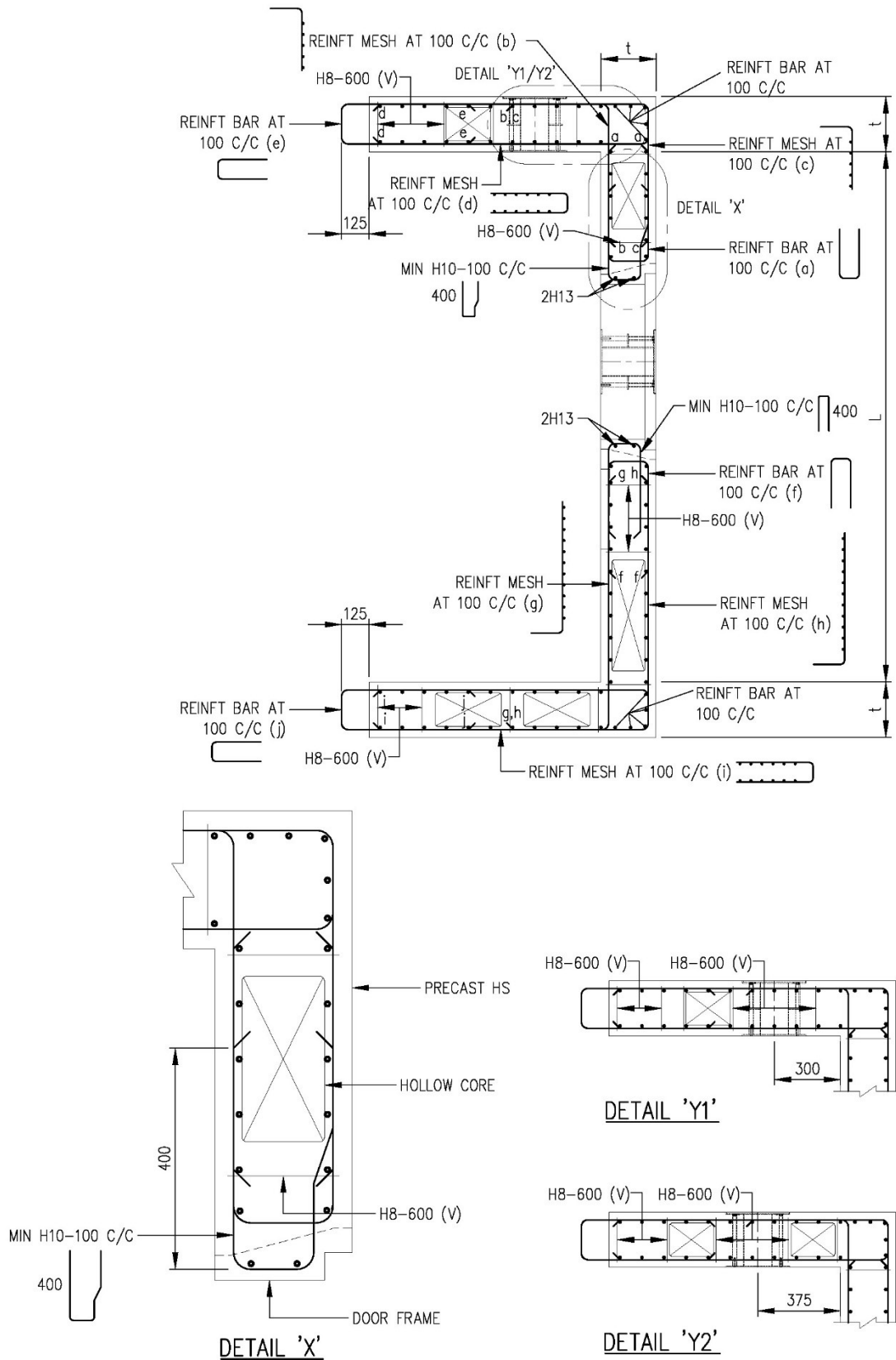

FIGURE 3.5.6.2(d) REINFORCEMENT BAR DETAILS OF WALL AND RIB FOR C-SHAPED PRECAST HS

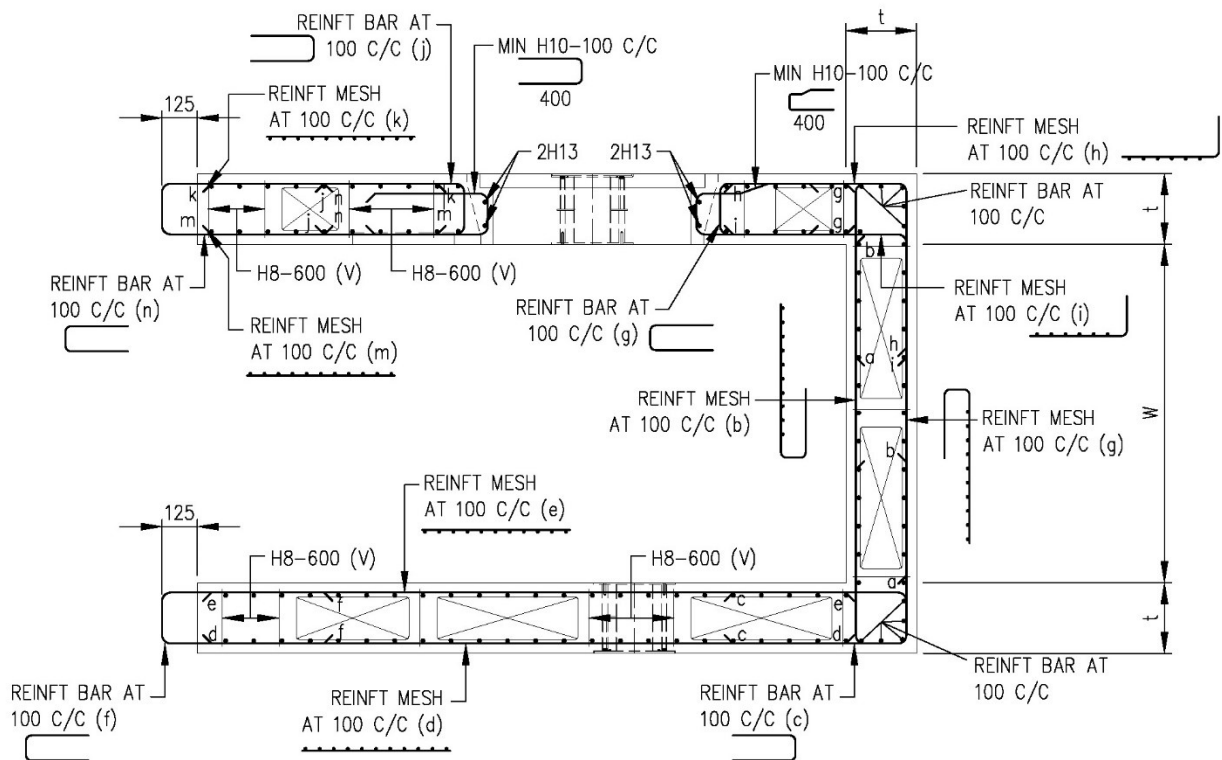
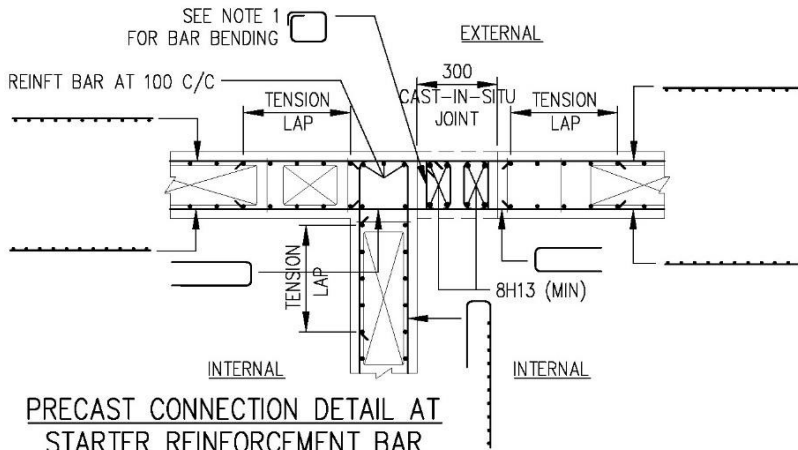

FIGURE 3.5.6.2(e) REINFORCEMENT BAR DETAILS OF WALL AND RIB FOR C-SHAPED PRECAST HS



PRECAST CONNECTION DETAIL AT STARTER REINFORCEMENT BAR LEVEL (TYPE 1)

NOTES:

1. PRE-BENT J-SHAPE BARS (a1) SHALL BE BENT AT SITE TO FORM A CLOSE LINK (a2) AS SHOWN IN DETAIL 'A' AT STARTER REINFORCEMENT BAR LEVEL.

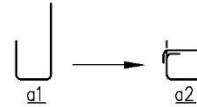

2. PRE-BENT U-SHAPE BARS (b1) SHALL BE BENT TO FORM PROJECTED LOOP BARS (b2) WITH ANCHORAGE LENGTH AS SHOWN IN DETAIL 'B'.

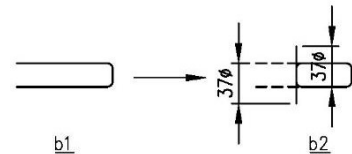

3. MINIMUM BAR SIZE OF THE LINK SHALL BE THE SAME AS THE WALL REINFORCEMENT OF THE HS.

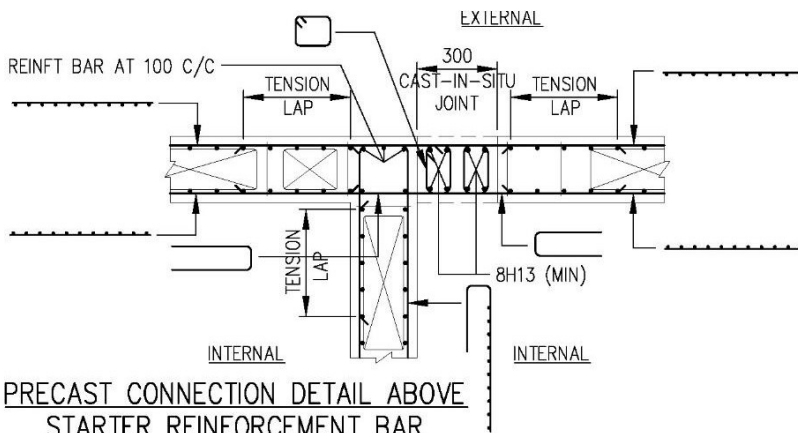

PRECAST CONNECTION DETAIL ABOVE STARTER REINFORCEMENT BAR LEVEL (TYPE 1)

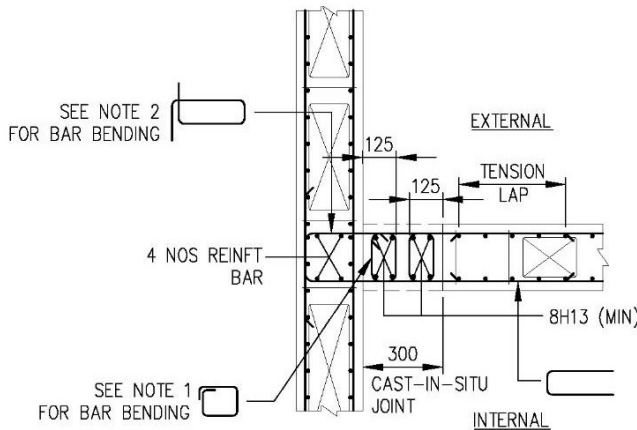

PRECAST CONNECTION DETAIL AT STARTER REINFORCEMENT BAR LEVEL (TYPE 2)

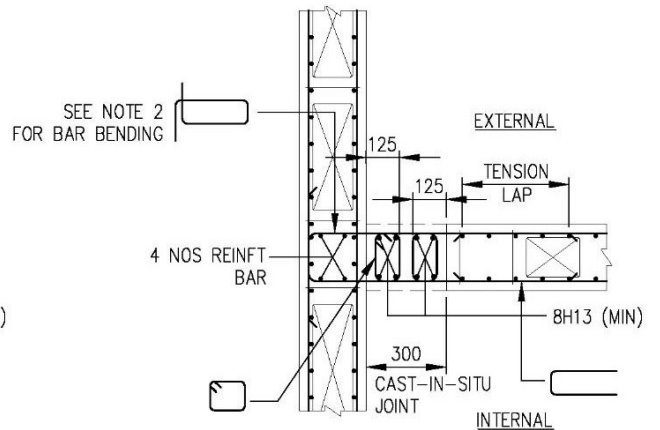

PRECAST CONNECTION DETAIL ABOVE STARTER REINFORCEMENT BAR LEVEL (TYPE 2)

FIGURE 3.5.6.2(f) CONNECTION DETAILS BETWEEN TWO PRECAST HS

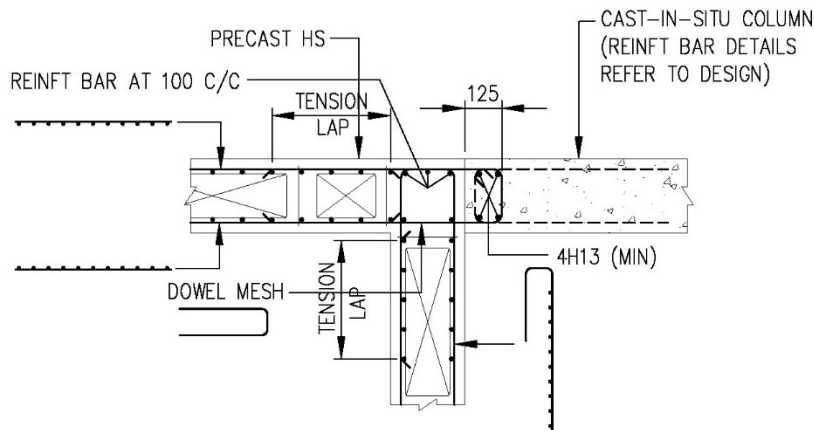

**PRECAST TO INSITU CONNECTION
REINFORCEMENT BAR DETAIL (TYPE 3)**

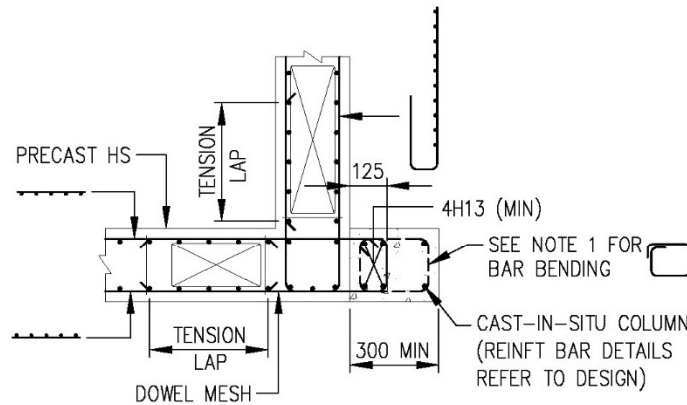

**PRECAST TO INSITU CONNECTION
AT STARTER REINFORCEMENT BAR
LEVEL (TYPE 4)**

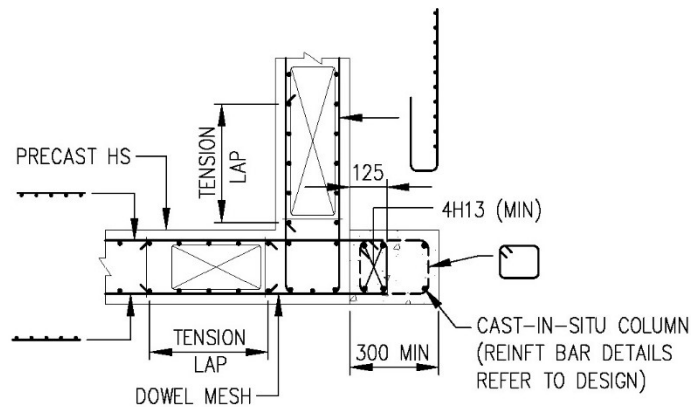

**PRECAST TO INSITU CONNECTION
ABOVE STARTER REINFORCEMENT
BAR LEVEL (TYPE 4)**

**FIGURE 3.5.6.2(g) CONNECTION DETAILS BETWEEN PRECAST HS
AND CAST IN-SITU WALL/COLUMN**

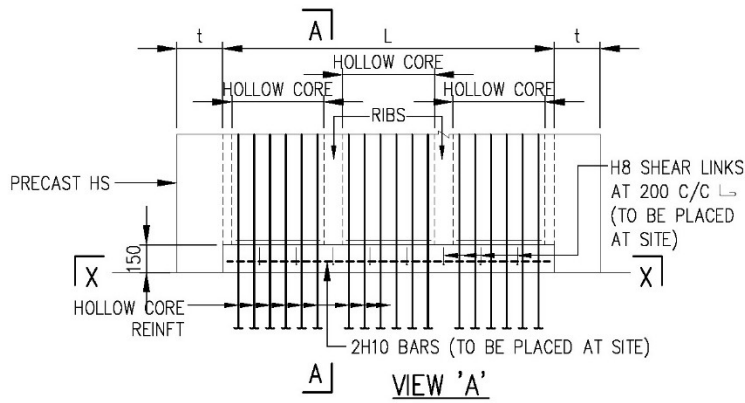

(NOTE: FOR CLARITY, REINFT MESH AT 100 C/C FOR PRECAST HS WALL IS NOT SHOWN)

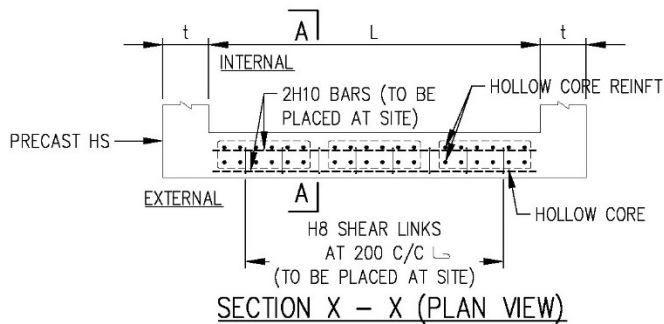

(NOTE: FOR CLARITY, REINFT MESH AT 100 C/C FOR PRECAST HS WALL IS NOT SHOWN)

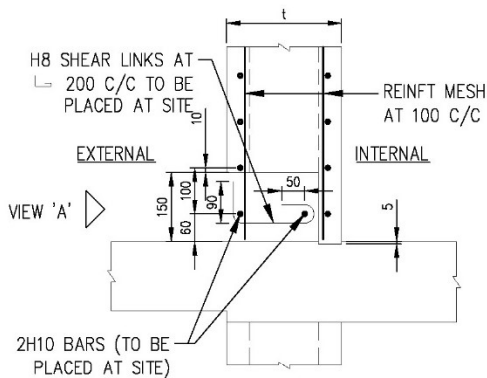

DETAIL '1A' (FOR PRECAST BOTTOM OPENING ON EXTERNAL FACE OF WALL)

(NOTE: FOR CLARITY, 6H8-100 (V) AT RIB ARE NOT SHOWN)

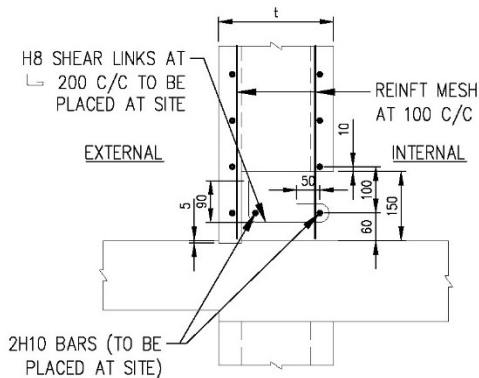

DETAIL '1B' (FOR PRECAST BOTTOM OPENING ON INTERNAL FACE OF WALL)

(NOTE: FOR CLARITY, 6H8-100 (V) AT RIB ARE NOT SHOWN)

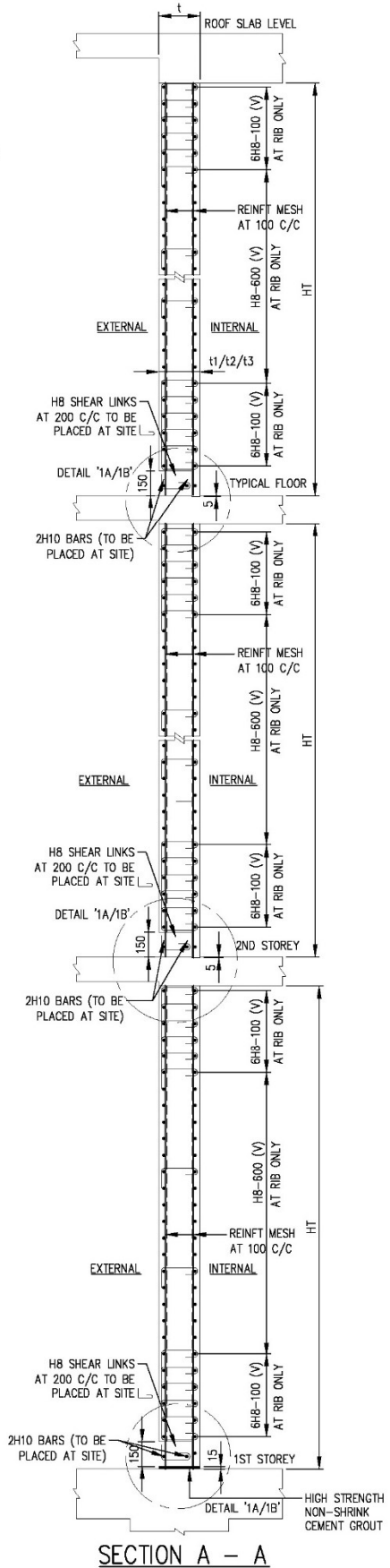

FIGURE 3.5.6.2(h) REINFORCEMENT BAR DETAILS AT CONCRETE RIB

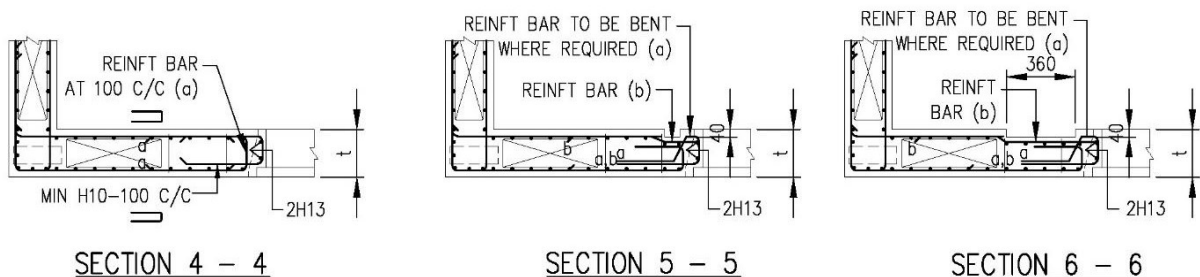
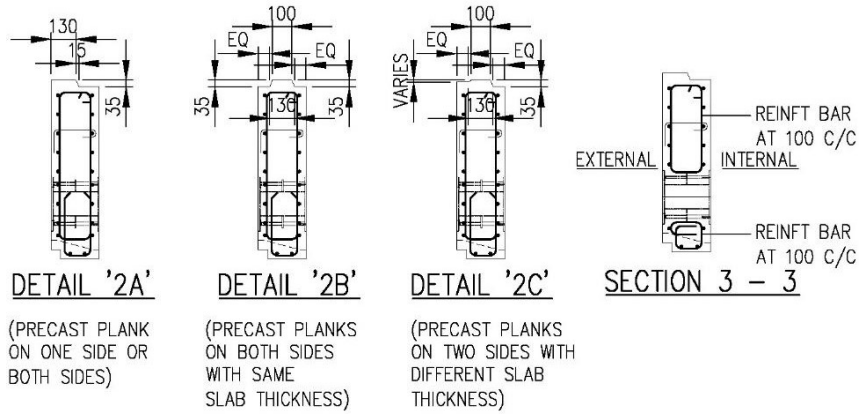
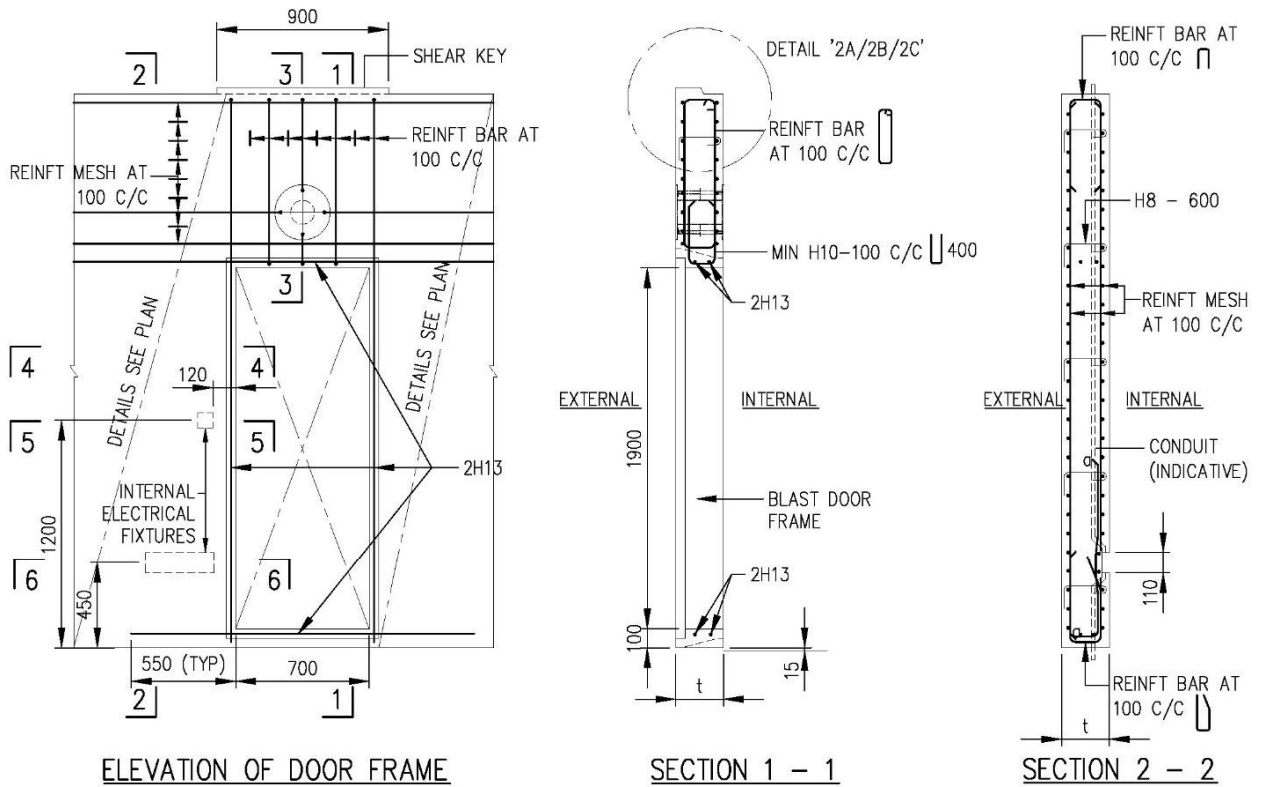

FIGURE 3.5.6.2(i) DETAILS OF REINFORCEMENT BARS NEAR DOOR FRAME AND AT ELECTRICAL FIXTURES ON INTERNAL FACE OF PRECAST HS

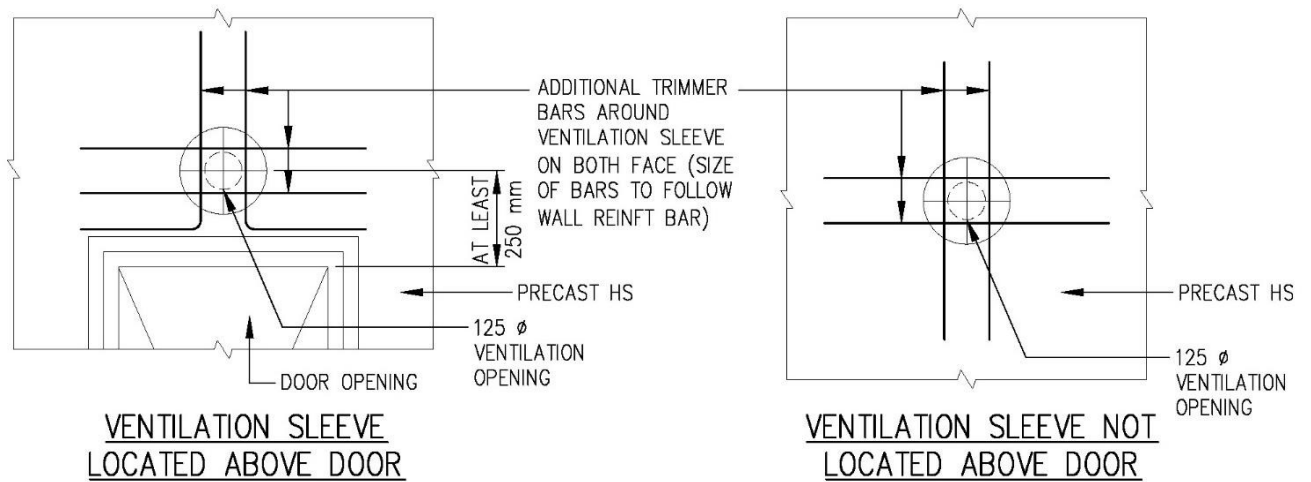

FIGURE 3.5.6.2(j) DETAILS OF TRIMMER BARS FOR VENTILATION SLEEVE

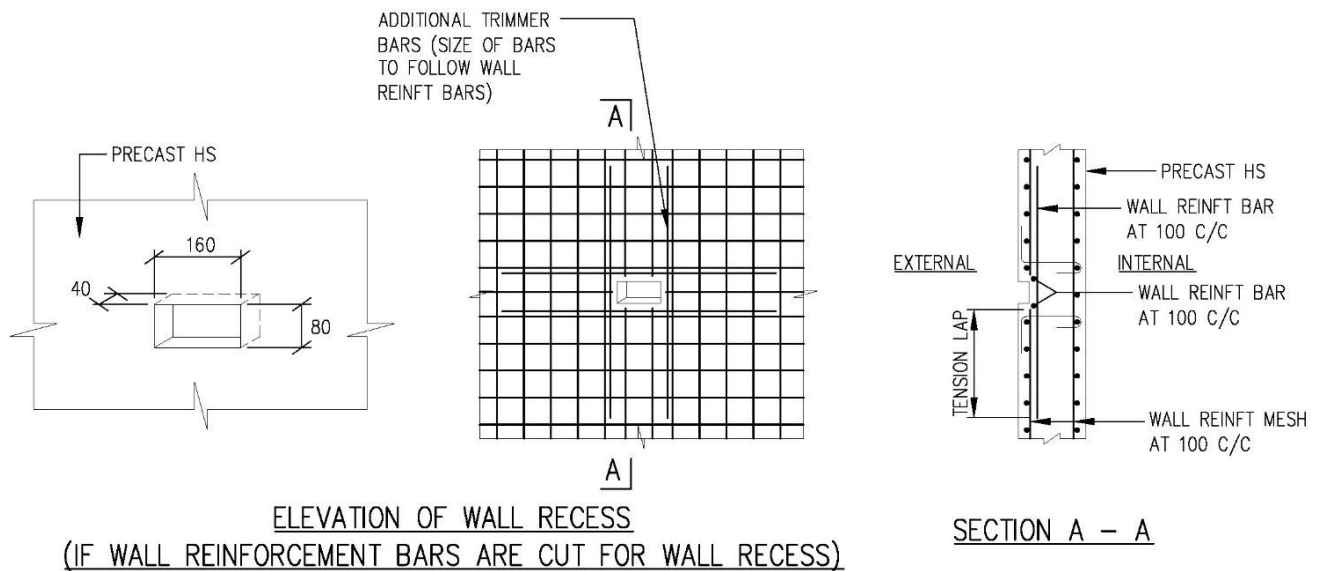
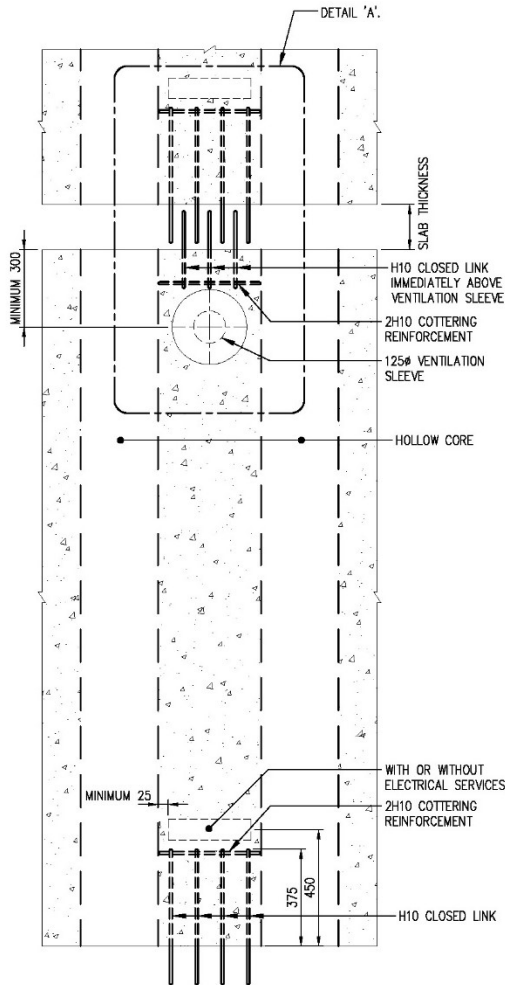
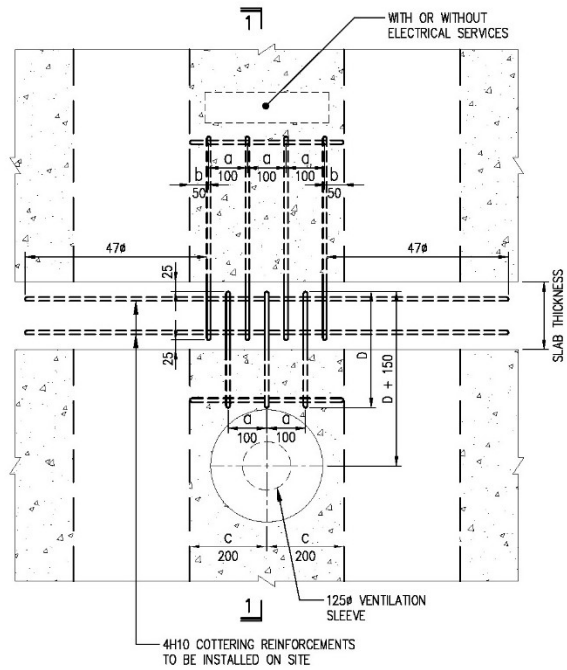

FIGURE 3.5.6.2(k) DETAILS OF TRIMMER BARS FOR WALL RECESS FOR HS DOOR HANDLE



PART ELEVATION OF PRECAST HS WALL WITH ELECTRICAL SERVICES AND VENTILATION SLEEVE

NOTE:
THE DETAIL IS APPLICABLE TO HS WALL WITHOUT ELECTRICAL SERVICES



DETAIL 'A': CONNECTION DETAIL SHOWING COTTERING REINFORCEMENT BARS

NOTE:
1) D = LENGTH OF CLOSED LINK IMMEDIATELY ABOVE VENTILATION SLEEVE. FOR SMALLER DIMENSION "C", THE REINFORCEMENT SPACING "a" AND DIMENSION "b" ARE TO BE REDUCED. FOR EXAMPLE, "C"=150mm, "a"=80mm AND "b"=30mm.

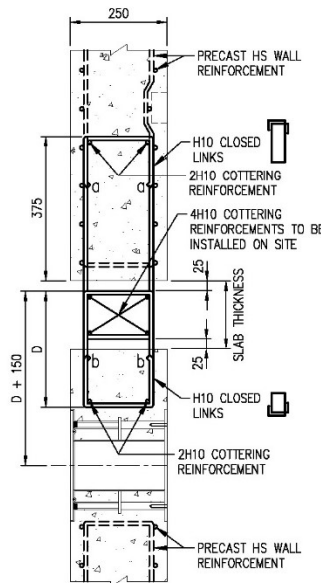

SECTION 1-1

NOTE:
D = LENGTH OF CLOSED LINK IMMEDIATELY ABOVE VENTILATION SLEEVE.

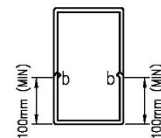
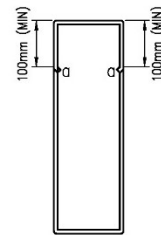

H10 CLOSED LINK DETAIL

FIGURE 3.5.6.2(i) PRECAST HS WALL WITH CONNECTION DETAILS FOR VENTILATION SLEEVE AND ELECTRICAL SERVICES

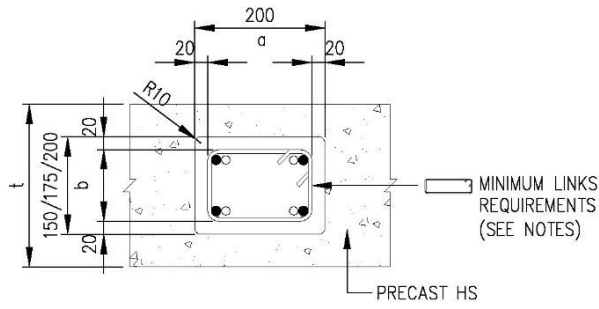

CAGE 1: 200 (a) X 150/175/200 (b)

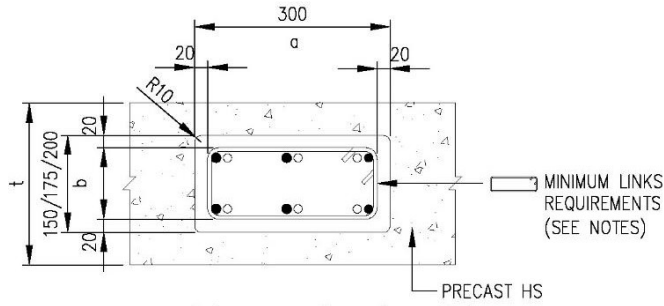

CAGE 2: 300 (a) X 150/175/200 (b)

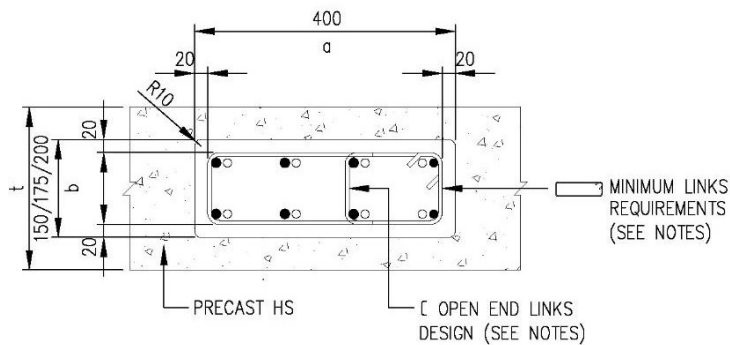

CAGE 3: 400 (a) X 150/200/175 (b)

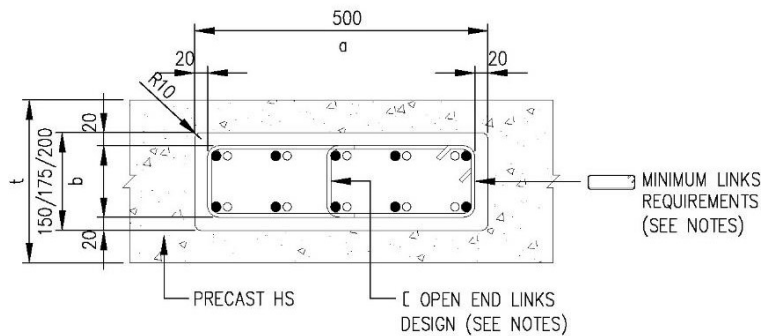

CAGE 4: 500 (a) X 150/175/200 (b)

NOTES:

1. DETAILS BELOW SHOW REINFORCEMENT BARS OF STEEL CAGE IN HOLLOW CORES AT LAPPING LEVEL.

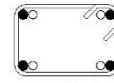

CAGE 1

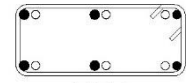

CAGE 2

2.  DENOTES UPPER LEVEL CAGE

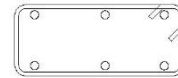

DENOTES CRANKED BARS OF LOWER LEVEL CAGE

3. CAGE REINFORCEMENT BARS SHALL BE PLACED WITH THE CRANKED PORTION OF THE MAIN BARS AT THE TOP LEVEL FOR LAPPING.

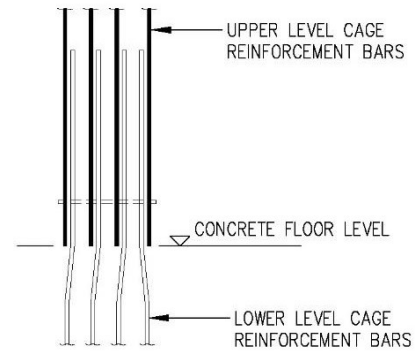

4. THERE IS ONLY ONE ARRANGEMENT OF CAGE REINFORCEMENT BARS PER CORE SIZE.

5. OPEN END LINKS  SHALL BE PROVIDED FOR MAIN BARS WHICH ARE LOCATED 150 mm AWAY FROM RESTRAINT BARS (SEE CAGE 3 AND CAGE 4 DETAILS).

6. THE CONCRETE GRADE IN HOLLOW CORE MUST BE AT LEAST THE SAME AS THE CONCRETE GRADE OF PRECAST HS WALL.

FIGURE 3.5.6.2(m) CAGE REINFORCEMENT BARS IN HOLLOW CORES

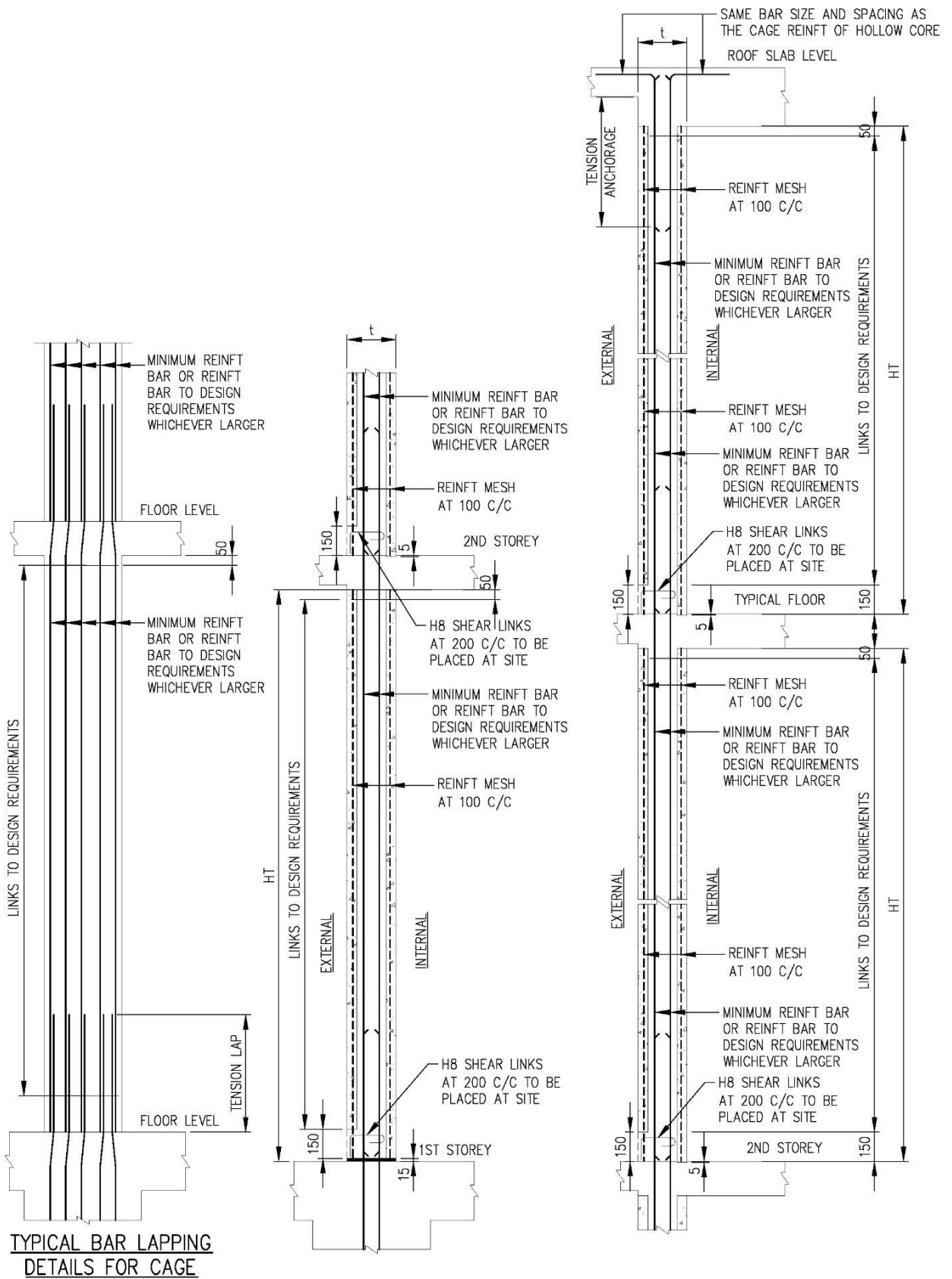
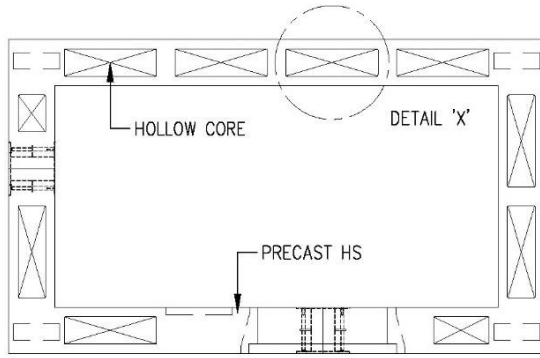
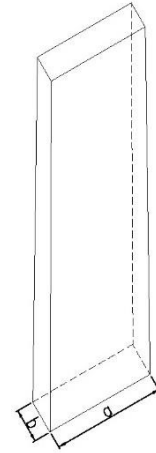

FIGURE 3.5.6.2(o) REINFORCEMENT BARS LAPPING IN HOLLOW CORES



PLAN OF PRECAST HS
 (SIZE AND ARRANGEMENT OF HOLLOW CORES SHOWN ARE INDICATIVE ONLY)



ISOMETRIC VIEW OF TAPERING CORE

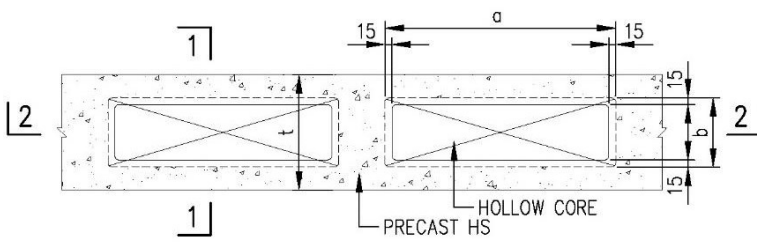

DETAIL 'X'

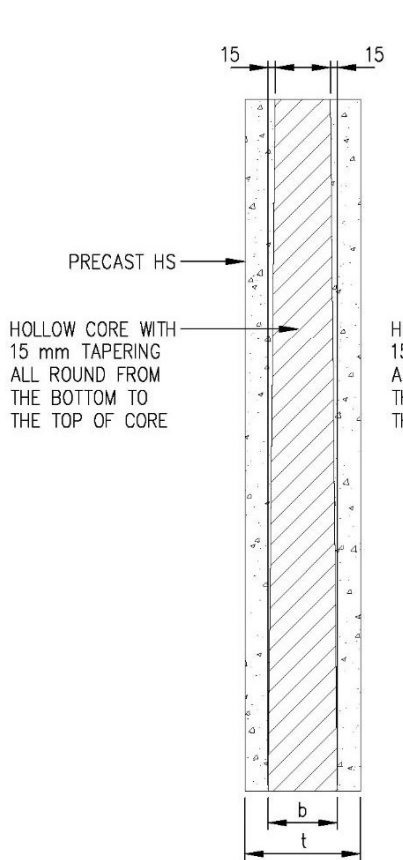

SECTION 1 - 1

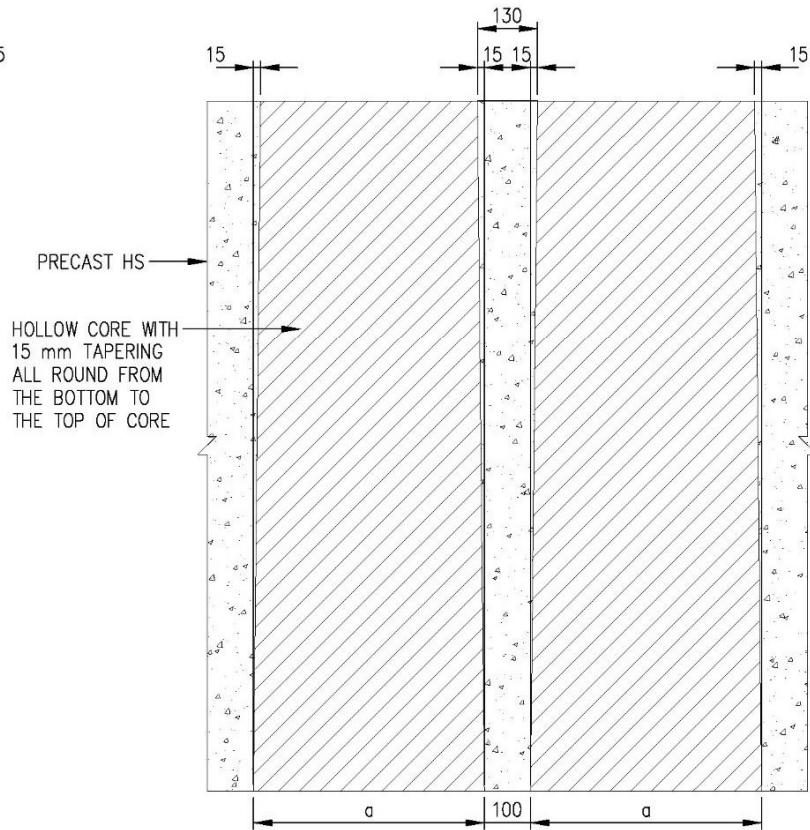

SECTION 2 - 2

FIGURE 3.5.6.2(p) HOLLOW CORE SHAPE

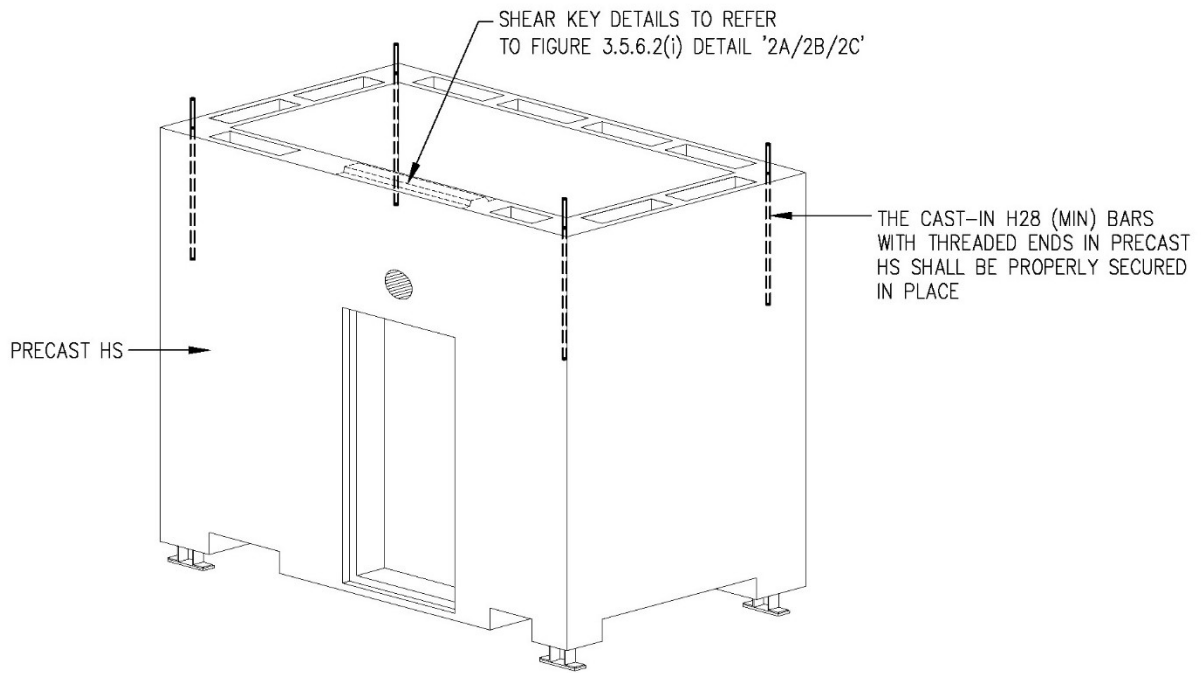

ISOMETRIC VIEW FROM TOP (TYPE 1)

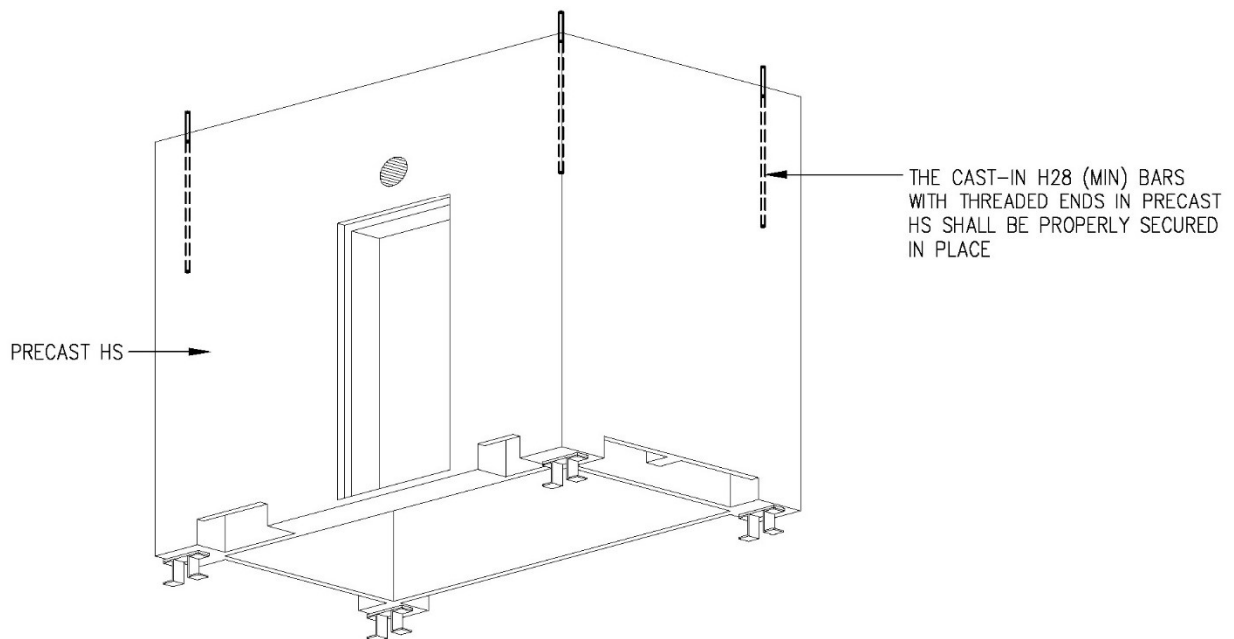

ISOMETRIC VIEW FROM BOTTOM (TYPE 1)

FIGURE 3.5.6.3(a) ISOMETRIC VIEW OF PRECAST HS WITH BOLTS AND STEEL PLATE CONNECTION (TYPE 1 WITHOUT BLOCKED-OUT FOR BEAM)

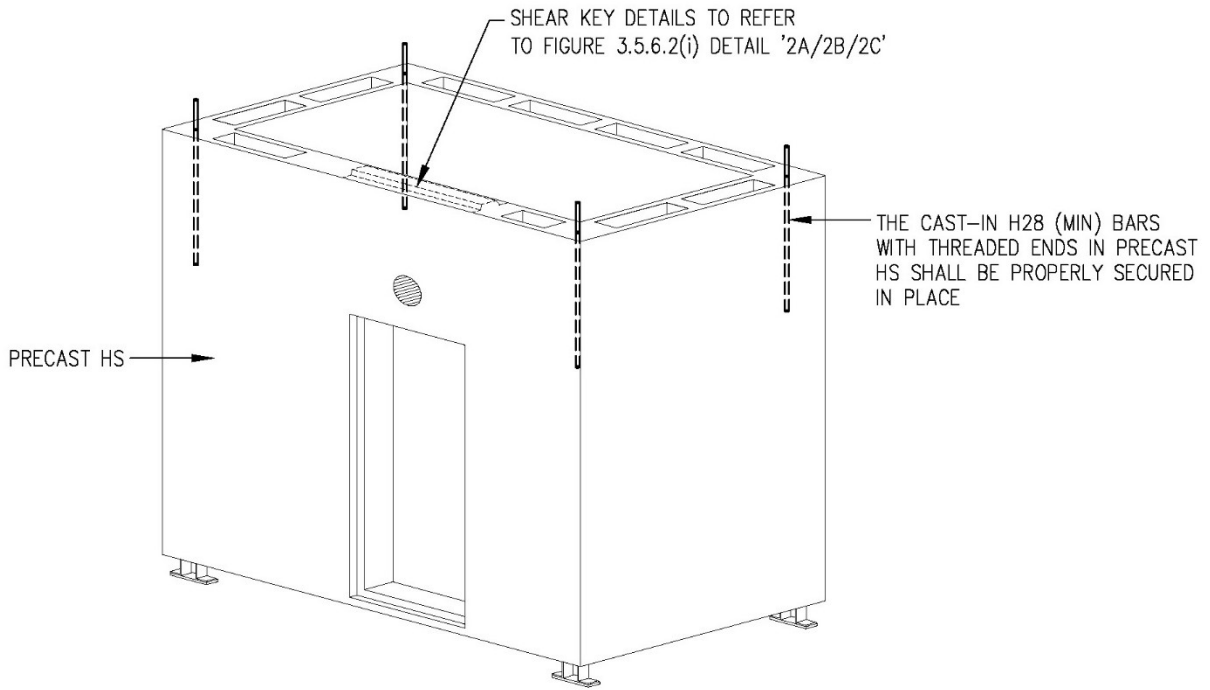

ISOMETRIC VIEW FROM TOP (TYPE 2)

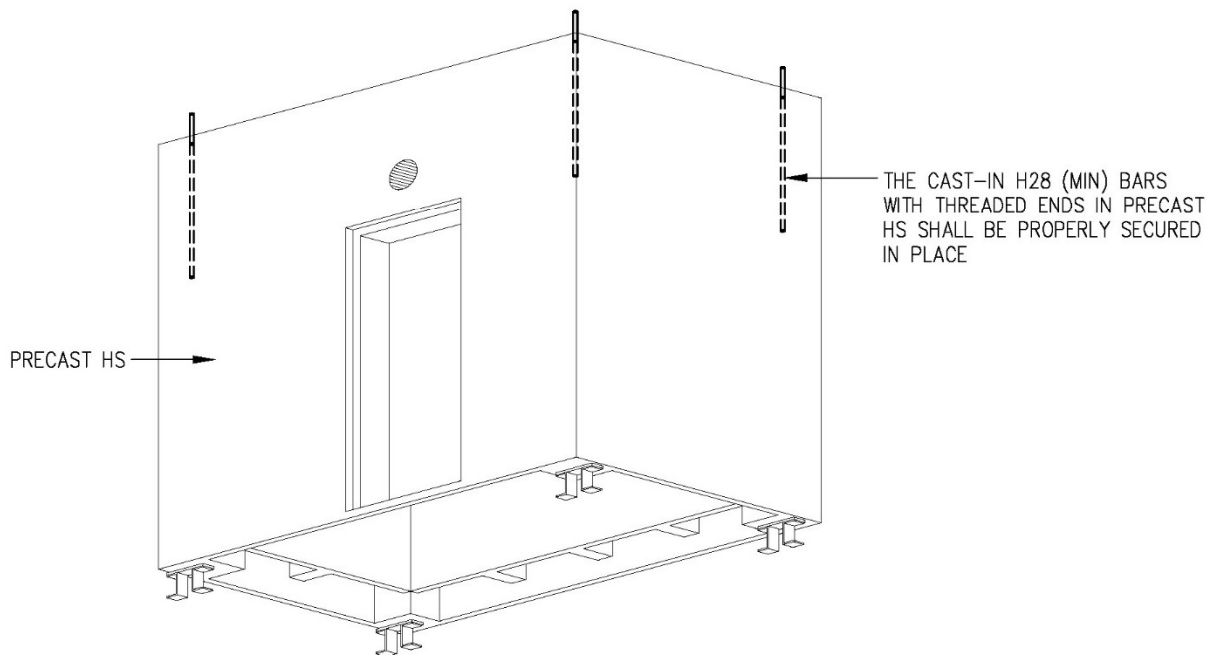

ISOMETRIC VIEW FROM BOTTOM (TYPE 2)

FIGURE 3.5.6.3(b) ISOMETRIC VIEW OF PRECAST HS WITH BOLTS AND STEEL PLATE CONNECTION (TYPE 2 WITHOUT BLOCKED-OUT FOR BEAM)

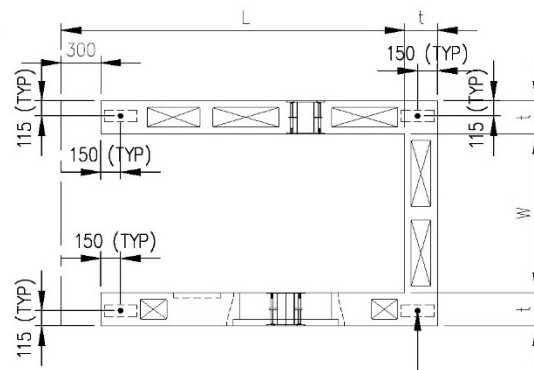
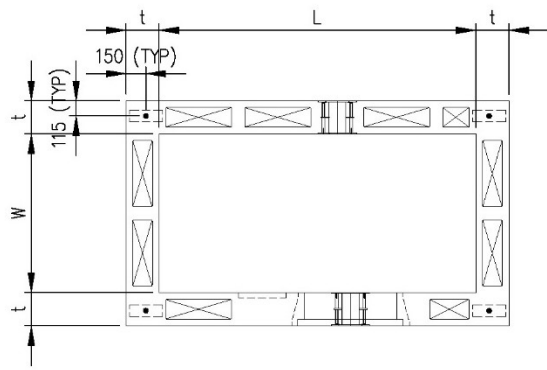

REFERENCE PLAN FOR 1ST PRECAST HS
(SIZE AND ARRANGEMENT OF CORES SHOWN IS INDICATIVE ONLY)

SPLICE SLEEVE AT SOFFIT OF 1ST PRECAST HS (TYPICAL) – SEE ELEVATION

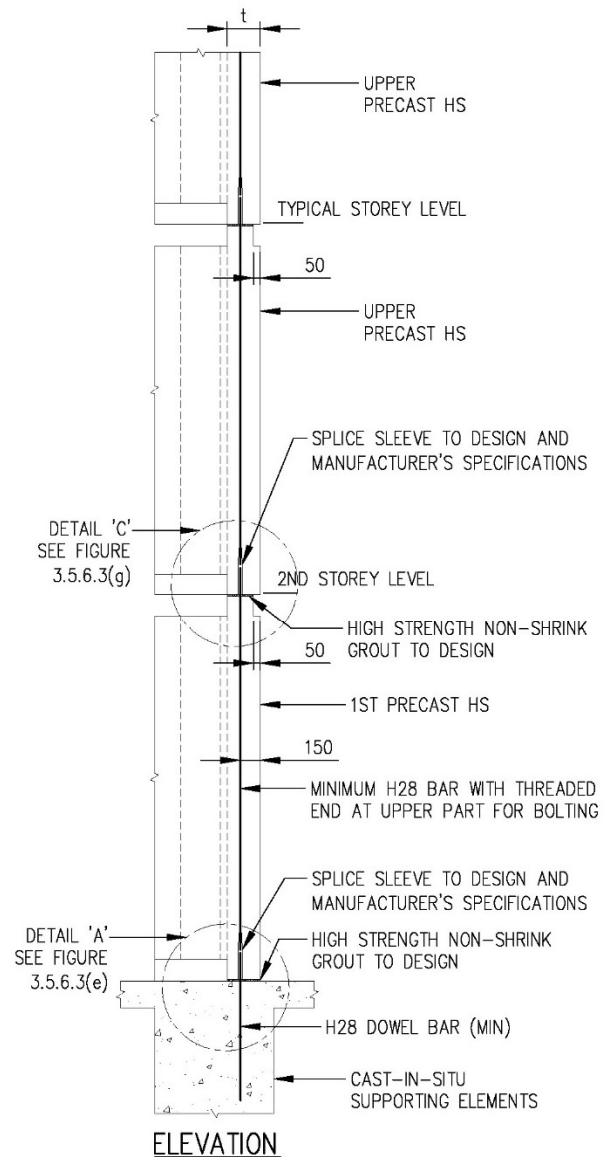
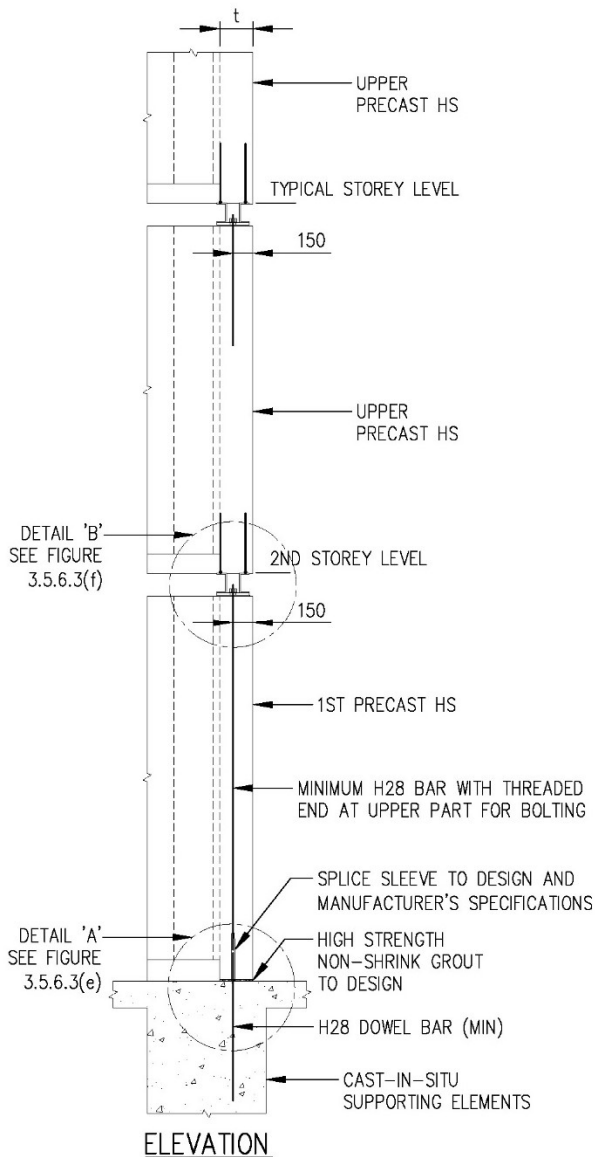
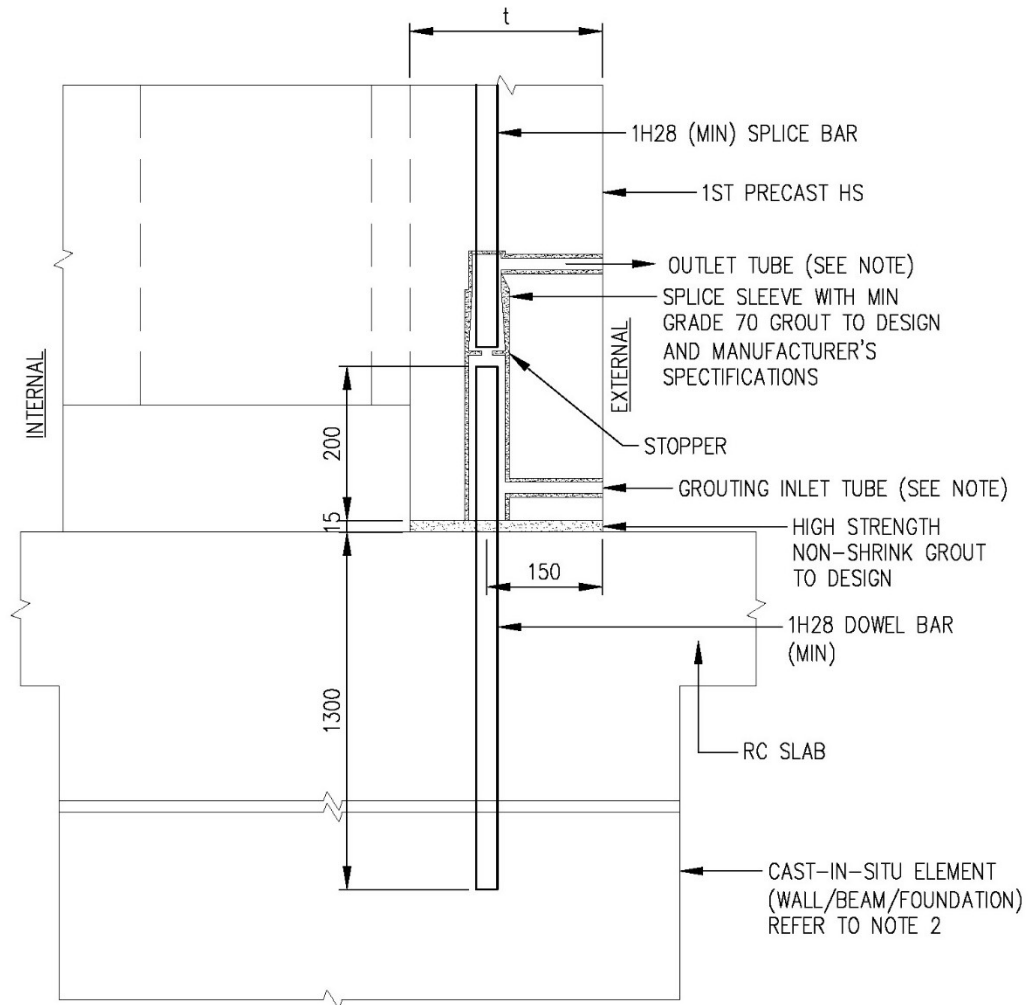

FIGURE 3.5.6.3(c) SPLICE SLEEVE CONNECTION DETAILS BETWEEN PRECAST HS AND CAST-IN-SITU ELEMENT AND BOLT CONNECTION DETAILS BETWEEN TWO PRECAST HS

FIGURE 3.5.6.3(d) SPLICE SLEEVE CONNECTION DETAILS FOR PRECAST HS TOWER



DETAIL 'A'
(TYPICAL DETAILS OF H28 (MIN) DOWEL BAR
FOR SPLICE SLEEVE CONNECTION BETWEEN 1ST
PRECAST HS AND CAST-IN-SITU ELEMENT)

NOTES:

1. RUBBER STOPPERS SHALL BE USED TO PLUG THE OUTLET AND GROUTING INLET TUBES IMMEDIATELY AFTER SLEEVE HAVE BEEN FILLED WITH GROUT.
2. CAST-IN-SITU ELEMENTS SUPPORTING THE LOADS FROM HS WALLS AS SHOWN IN DETAIL 'A' SHALL BE DESIGNED BY QUALIFIED PERSON (PE) TO FULFILL STRUCTURAL SAFETY REQUIREMENTS AND TECHNICAL REQUIREMENTS OF HS.

FIGURE 3.5.6.3(e) CONNECTION DETAILS BETWEEN LOWER AND UPPER
PRECAST HS (DETAIL 'A')

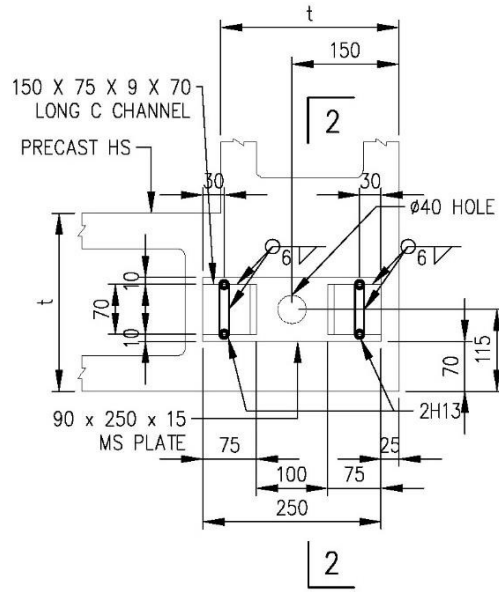

SECTION 1 - 1

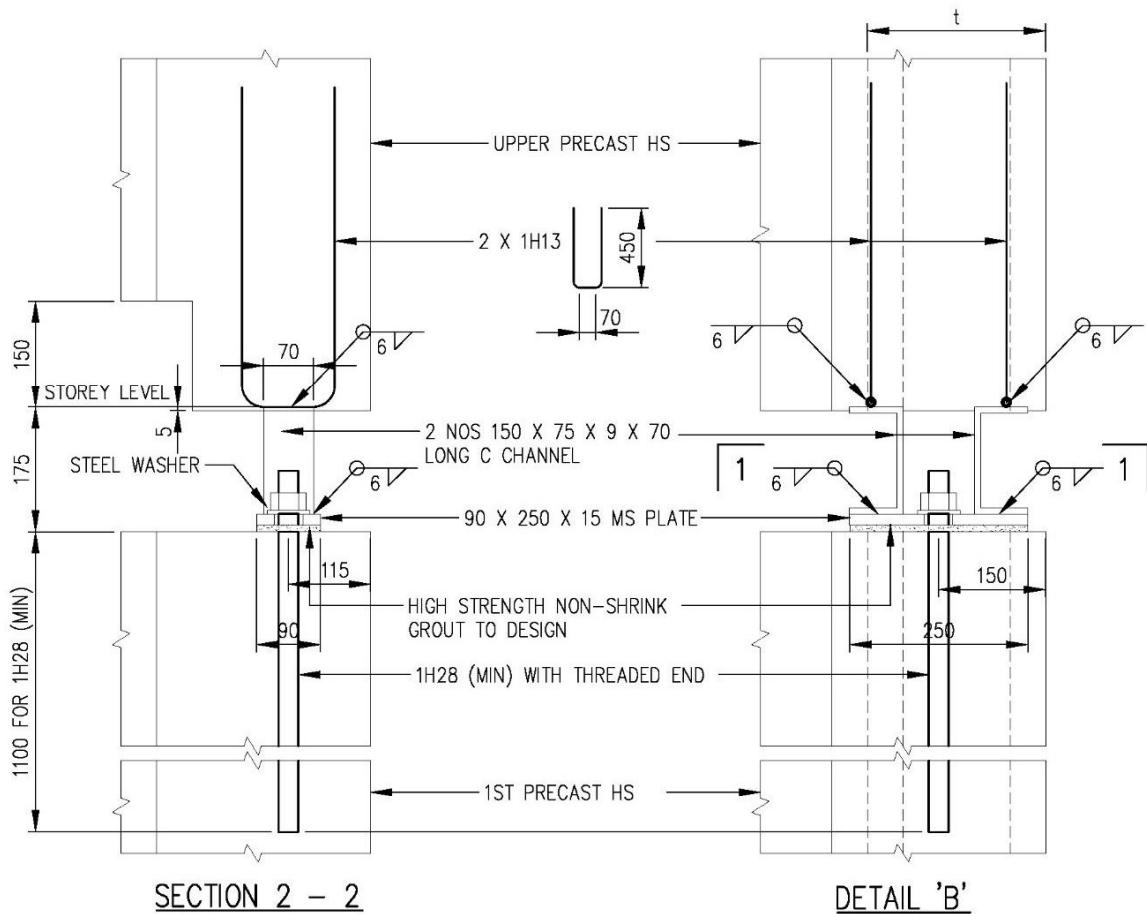

SECTION 2 - 2

DETAIL 'B'

FIGURE 3.5.6.3(f) CONNECTION DETAILS BETWEEN LOWER AND UPPER PRECAST HS (DETAIL 'B')

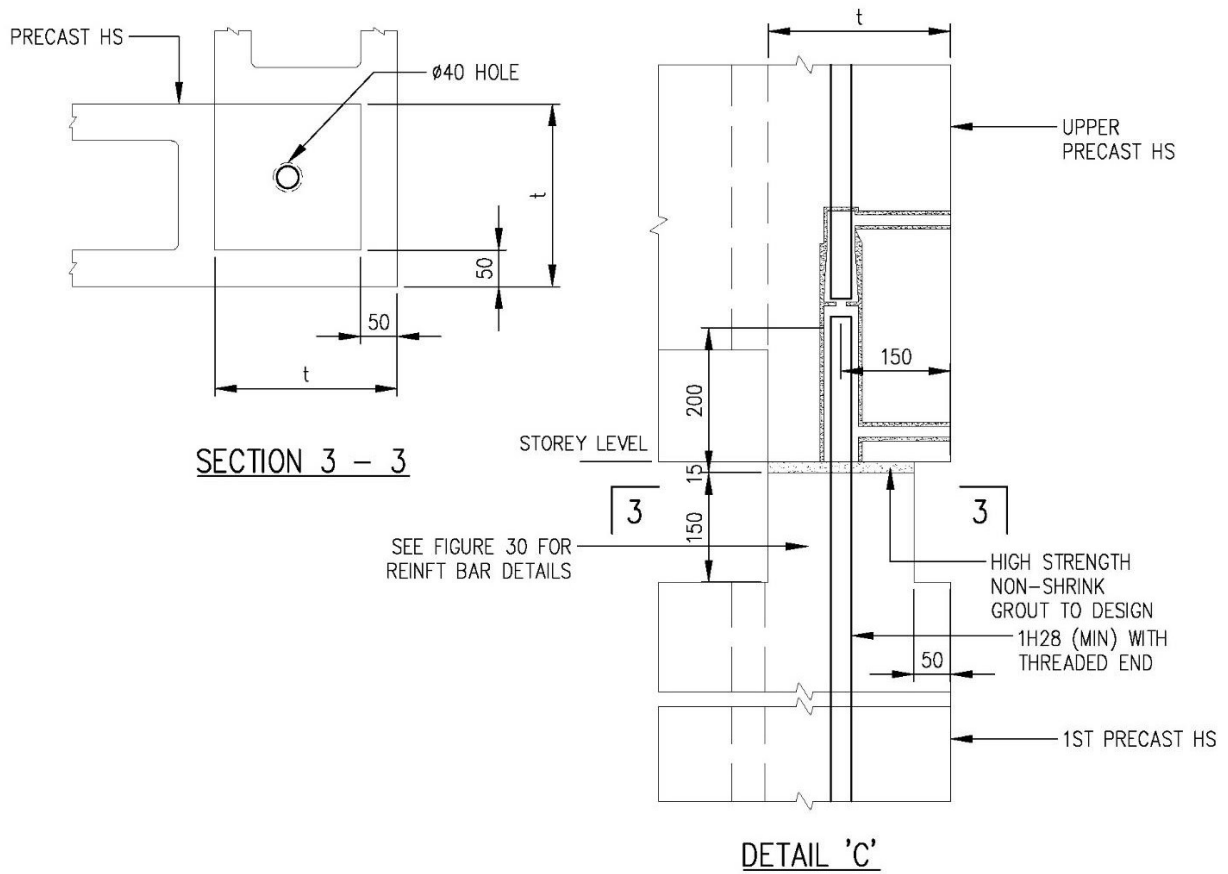
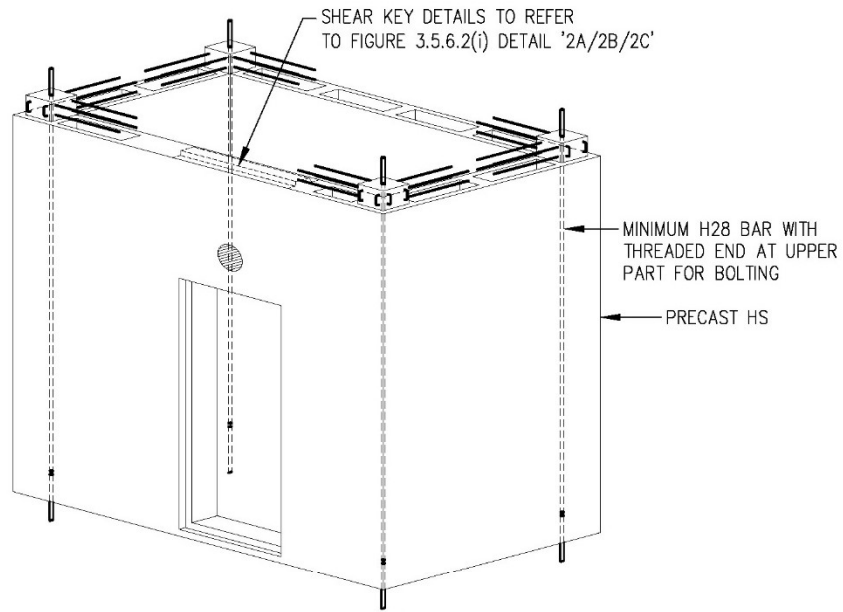
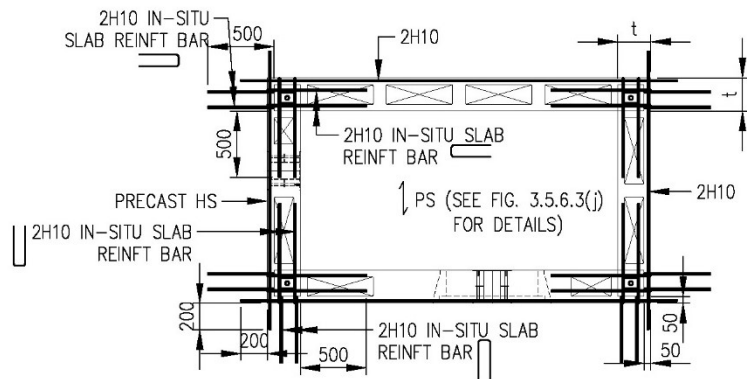

FIGURE 3.5.6.3(g) CONNECTION DETAILS BETWEEN LOWER AND UPPER PRECAST HS (DETAIL 'C')



ISOMETRIC VIEW FROM TOP

(FOR ILLUSTRATION, SIZE AND ARRANGEMENT SHOWN ARE INDICATIVE ONLY)



PLAN VIEW WITH DISCONTINUED EDGE AT ONE FACE

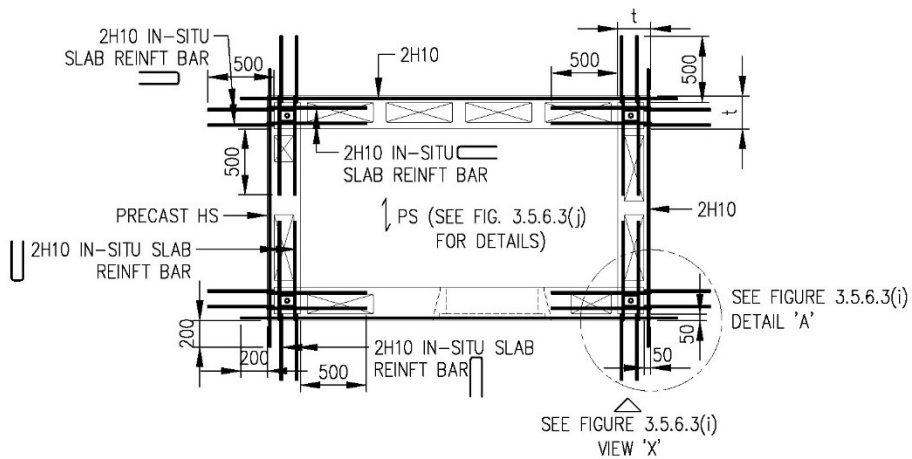

PLAN VIEW WITH CONTINUOUS EDGE

FIGURE 3.5.6.3(h) ISOMETRIC VIEW OF PRECAST HS WITH SPLICE SLEEVE CONNECTION (REINFORCEMENT BAR DETAILS)

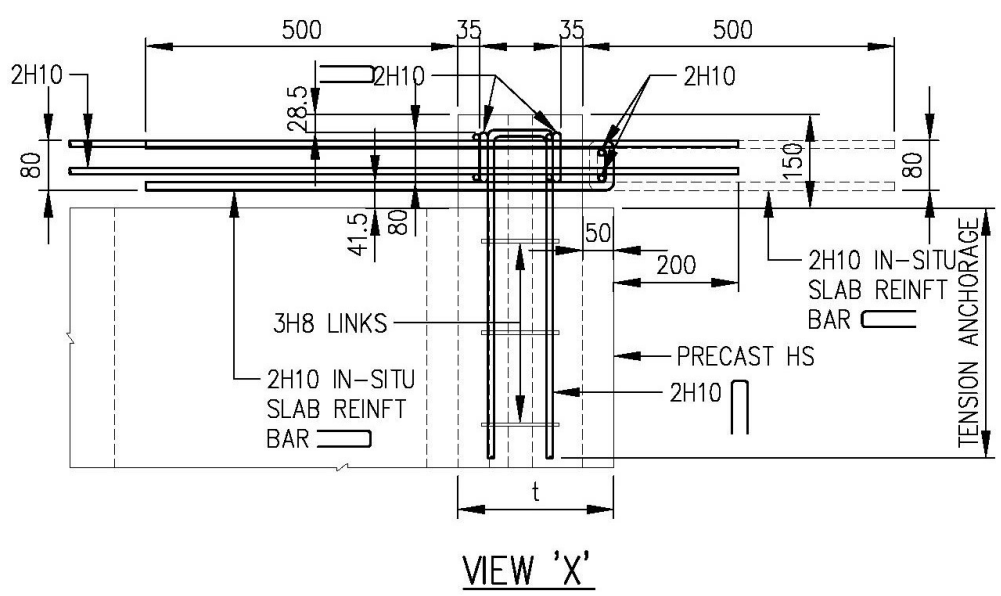
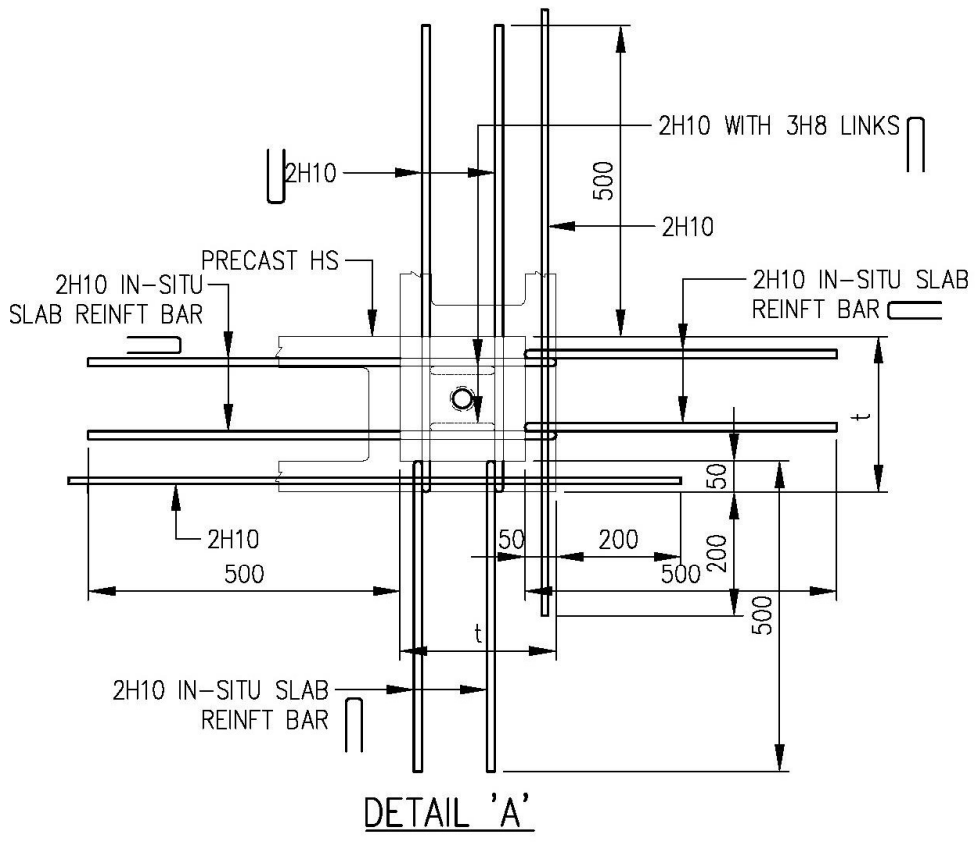

FIGURE 3.5.6.3(i) DETAIL OF SPLICE SLEEVE CONNECTION

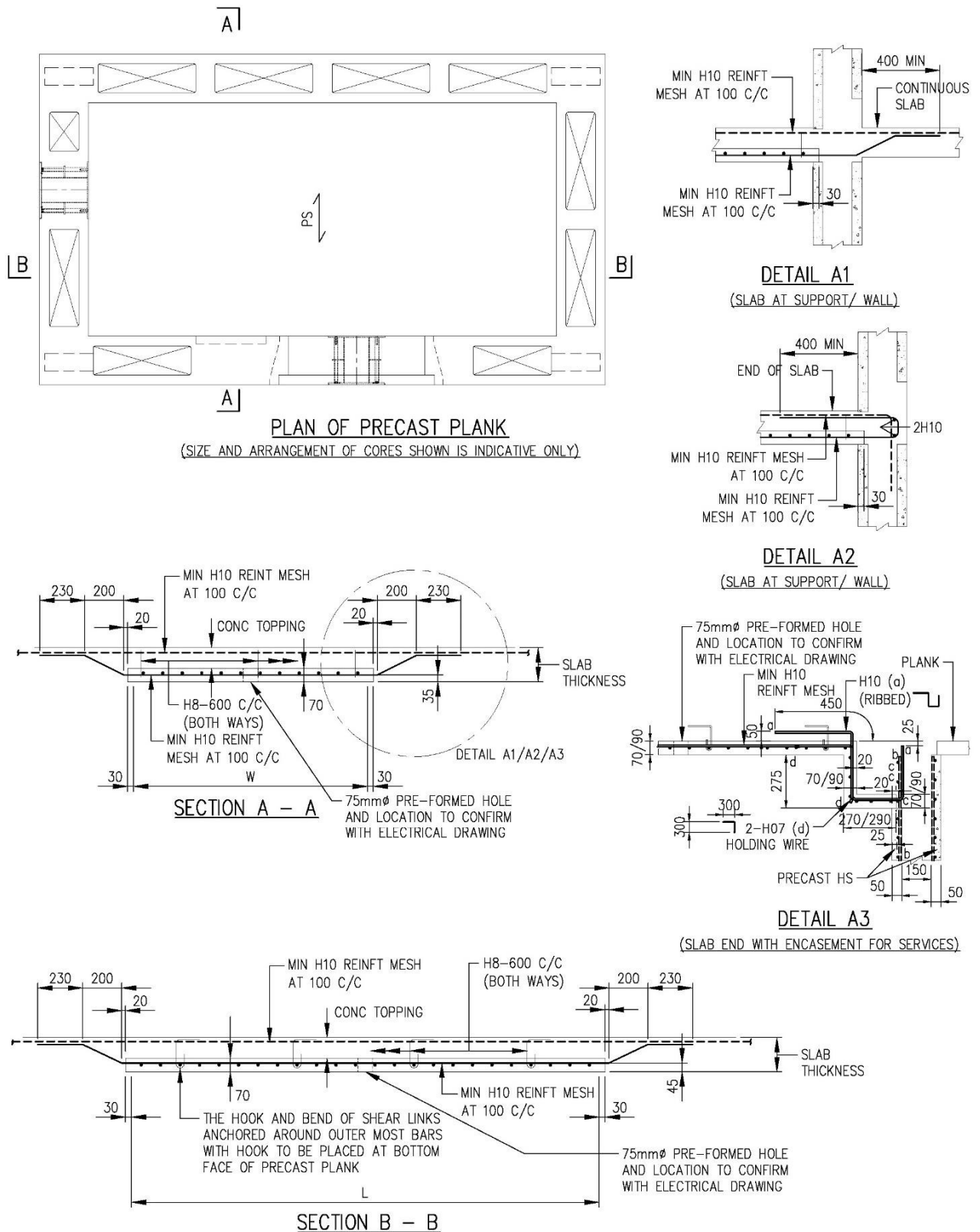

FIGURE 3.5.6.3(i) DETAILS OF PRECAST PLANK (MARKED AS PS) AND CONCRETE TOPPING

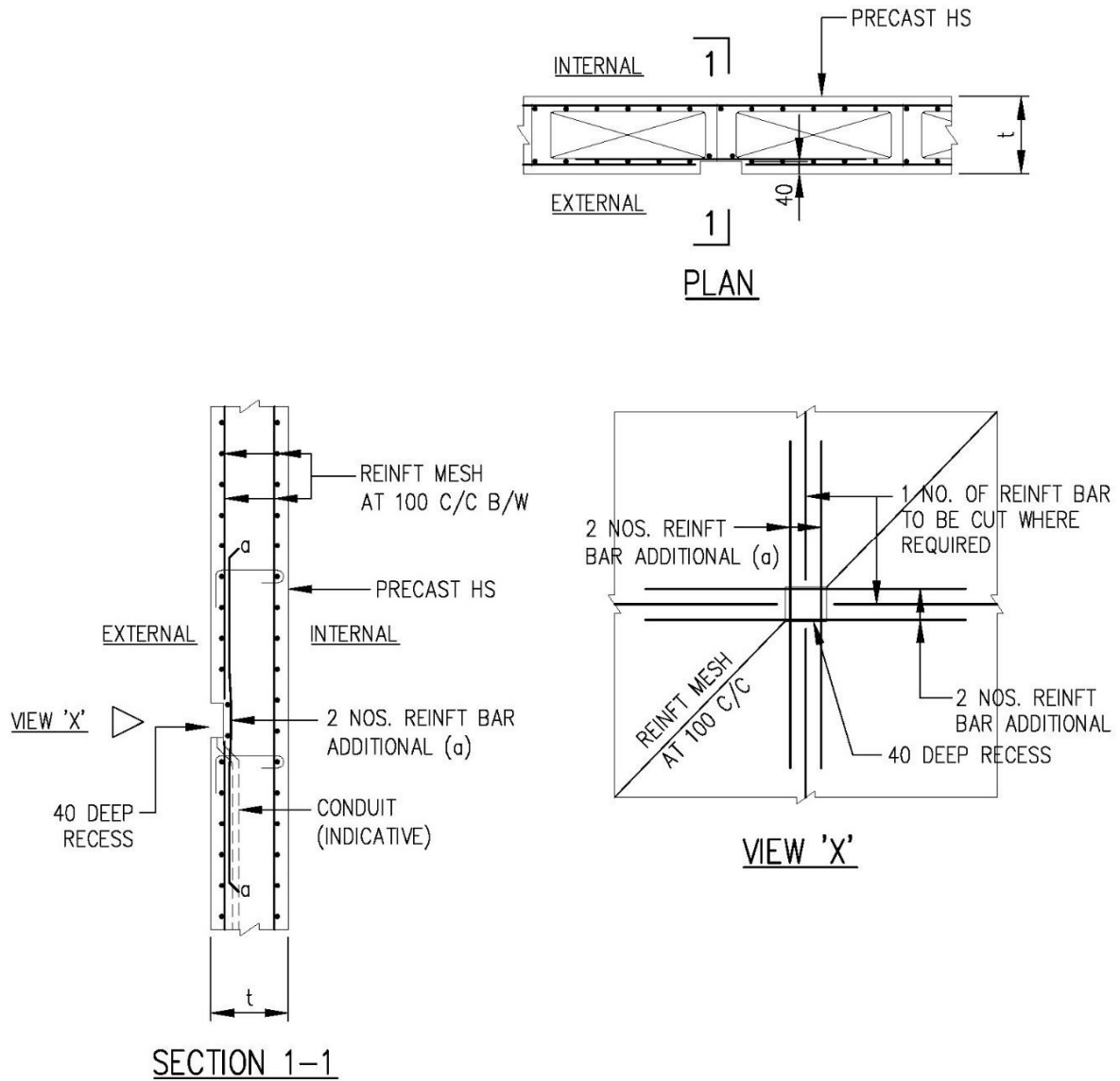

FIGURE 3.5.6.3(k) ELECTRICAL FIXTURES ON EXTERNAL FACE OF PRECAST HS

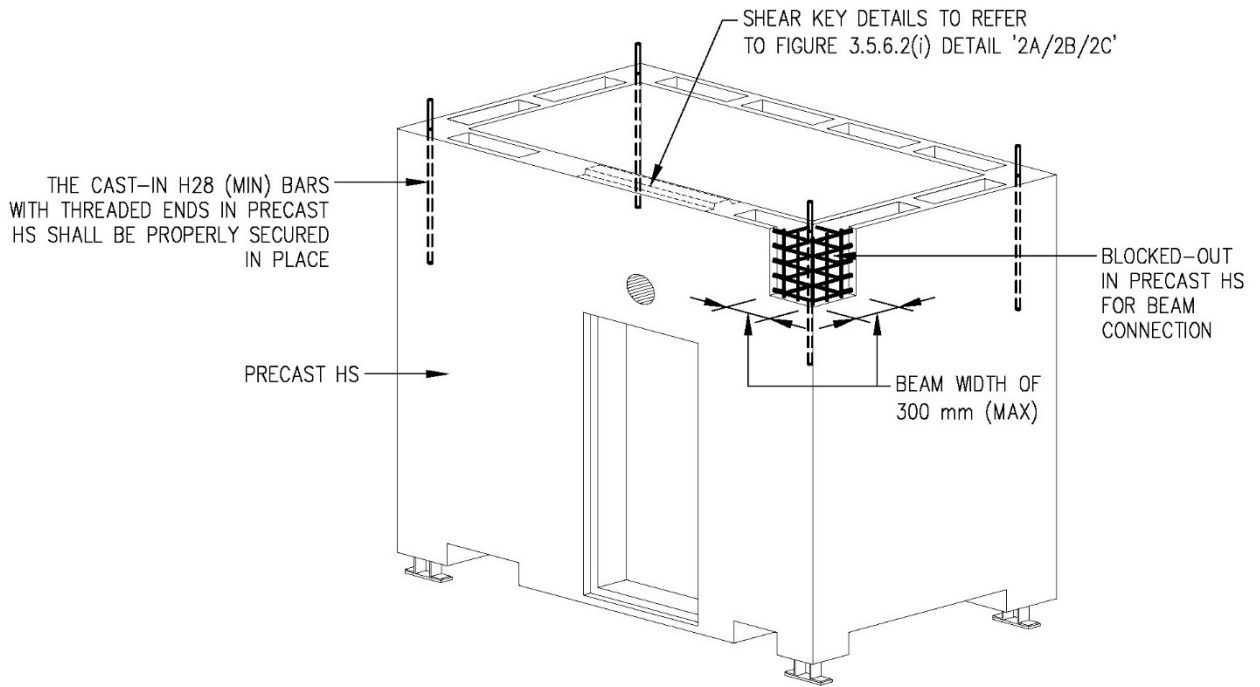

FIGURE 3.5.6.3(i) ISOMETRIC VIEW OF PRECAST HS WITH BOLTS AND STEEL PLATES CONNECTION (TYPE 3 WITH BLOCKED-OUT FOR BEAM)

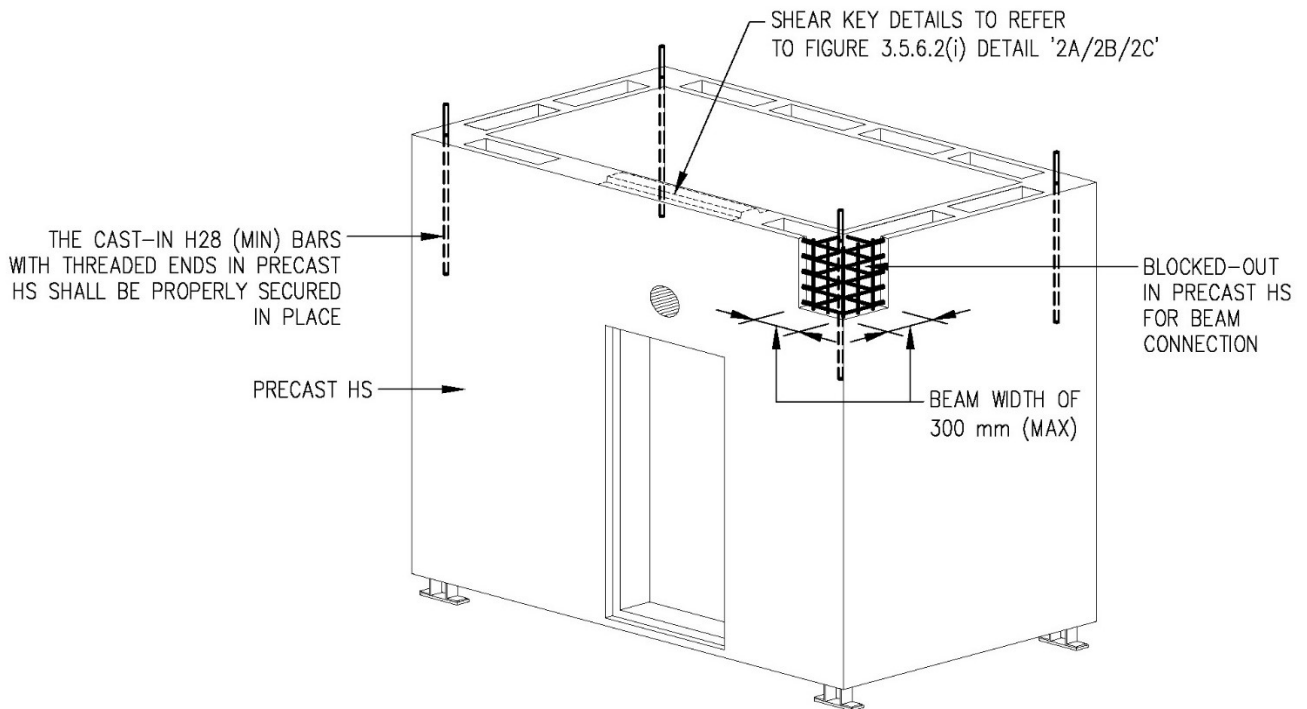
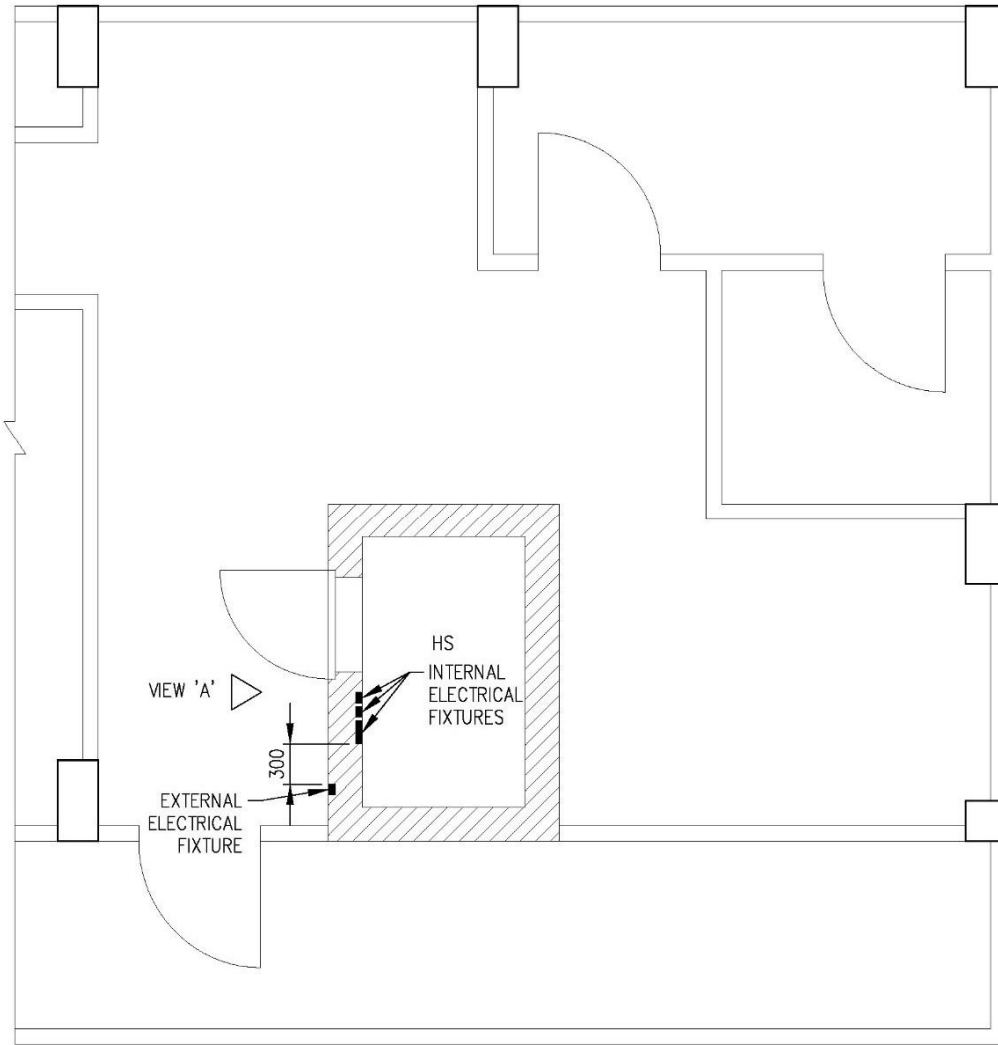

FIGURE 3.5.6.3(m) ISOMETRIC VIEW OF PRECAST HS WITH BOLTS AND STEEL PLATES CONNECTION (TYPE 4 WITH BLOCKED-OUT FOR BEAM)



PLAN

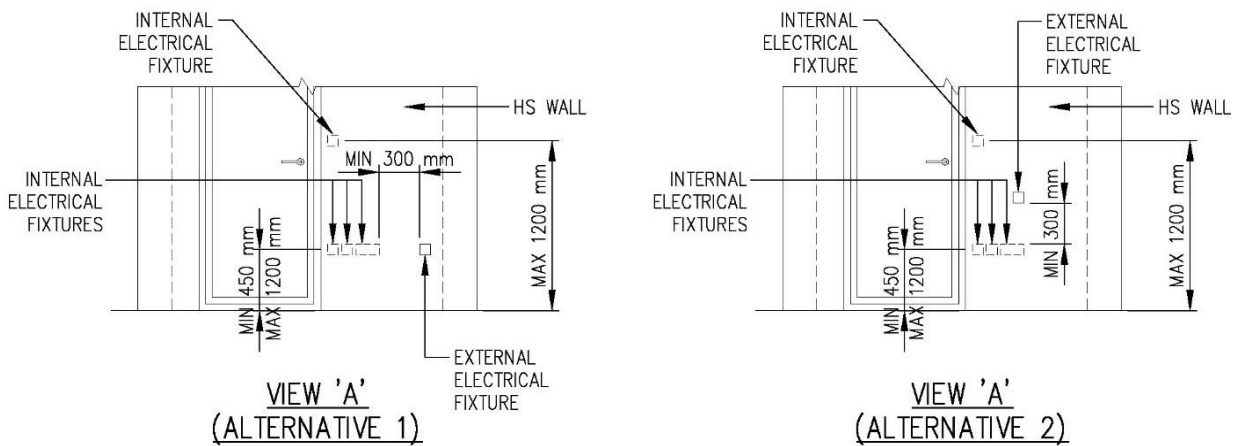

FIGURE 3.6.1(b) MOUNTING OF SERVICES ON EXTERNAL WALL OF A HS

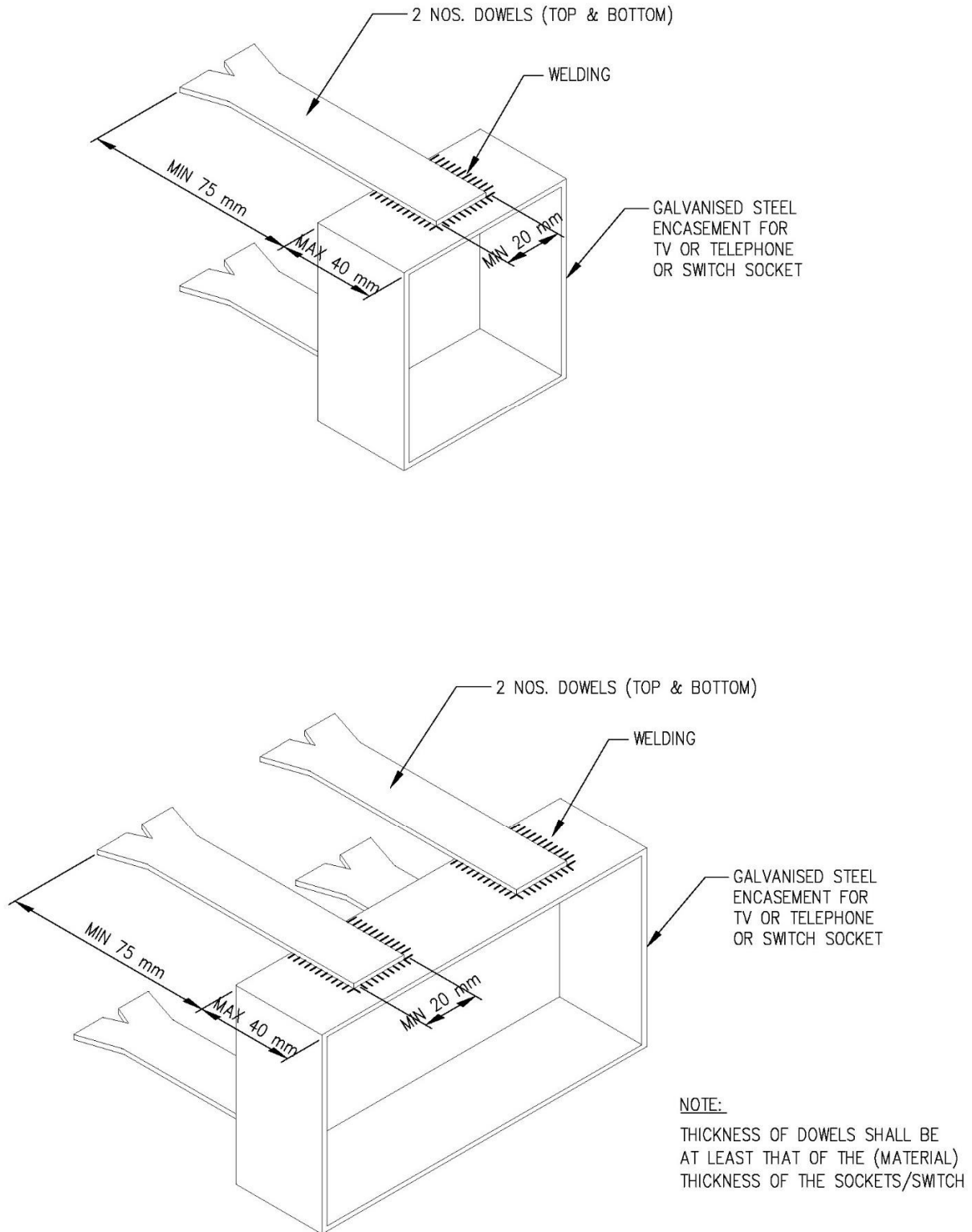
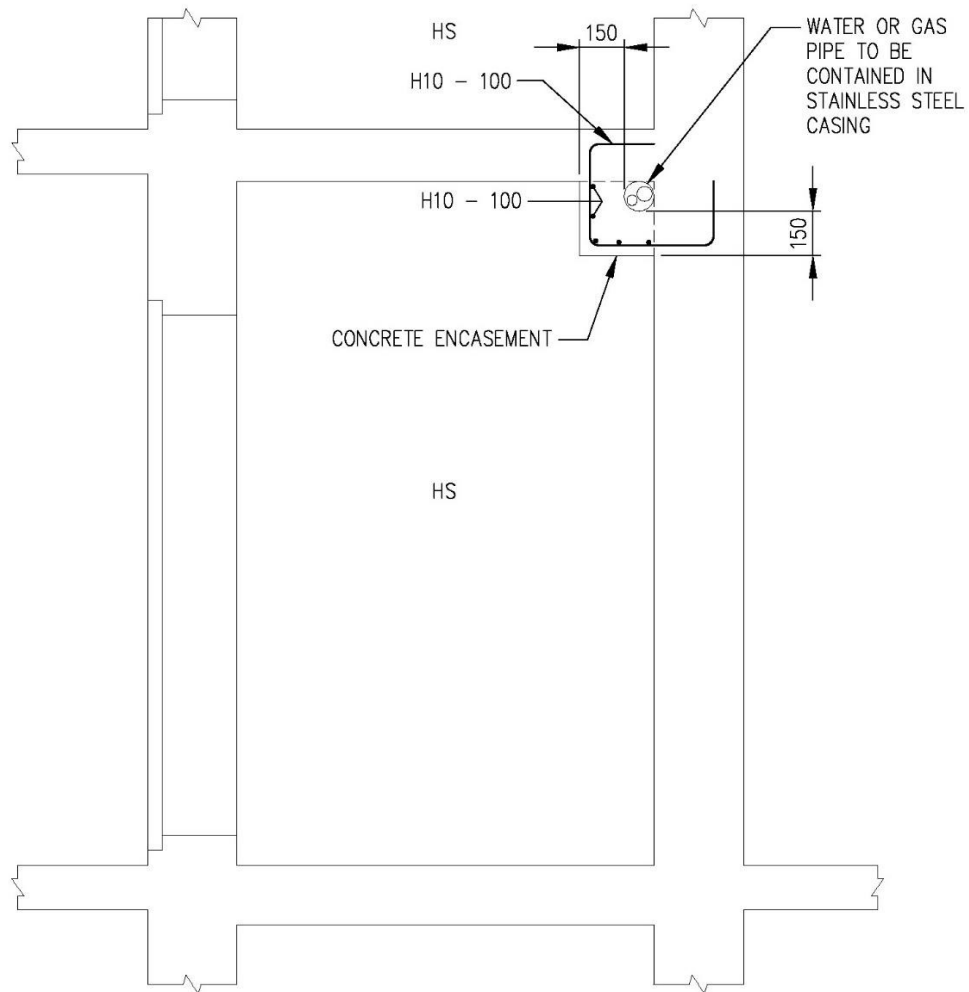
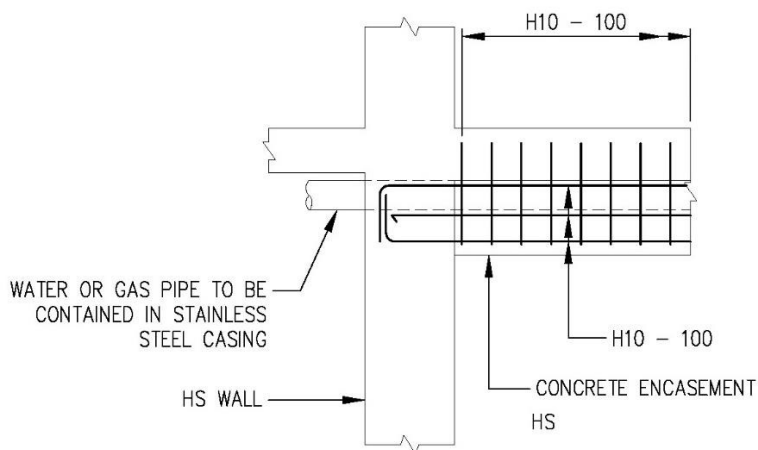

FIGURE 3.6.1(d) TYPICAL DETAILS OF EMBEDDED SOCKET/SWITCH



SECTION OF HS



END CONNECTION DETAILS

FIGURE 3.6.2 ENCASEMENT DETAILS OF WATER/GAS SERVICE PIPES PENETRATING THROUGH HS WALL

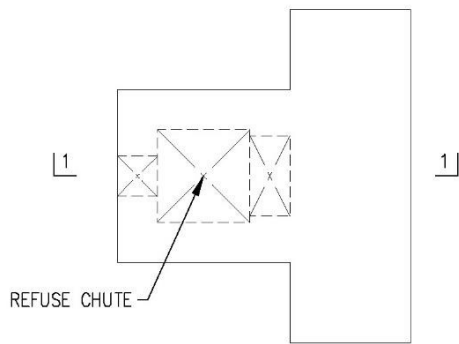

REFUSE CHUTE PLAN

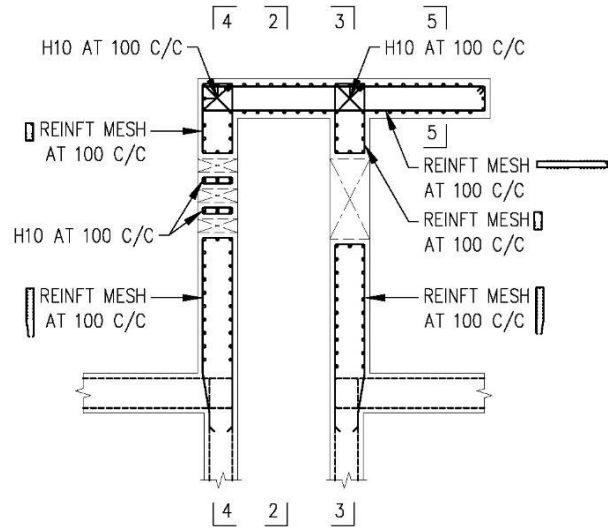

SECTION 1-1

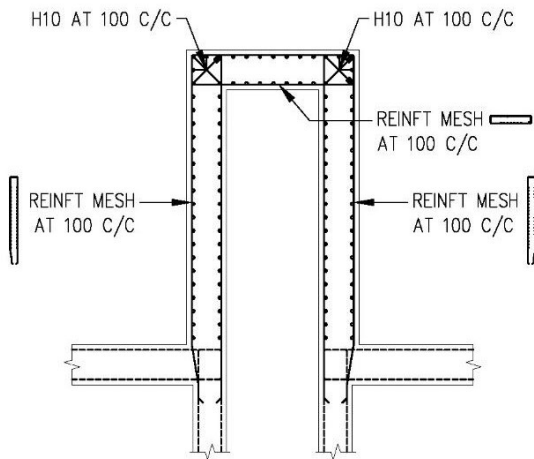

SECTION 2-2

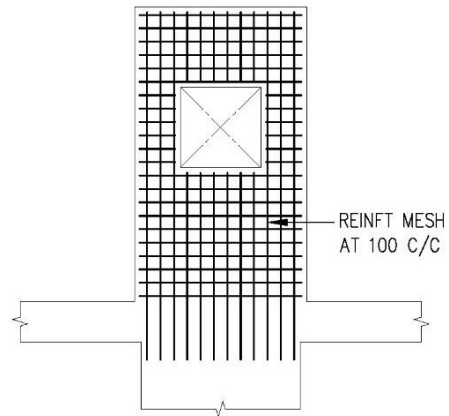

SECTION 3-3

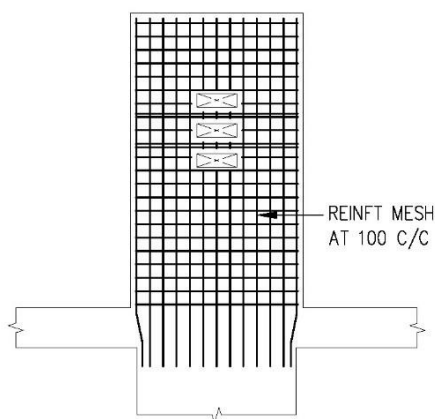

SECTION 4-4

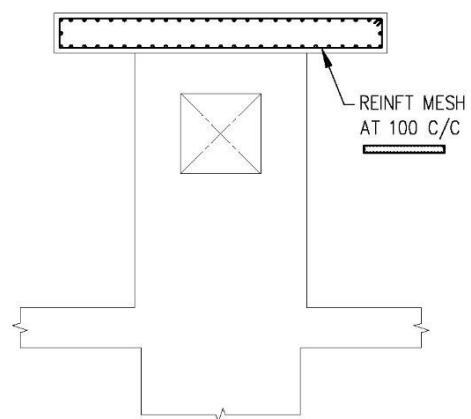

SECTION 5-5

FIGURE 3.6.3(a) REINFORCEMENT DETAIL OF REFUSE CHUTE ABOVE ROOF LEVEL

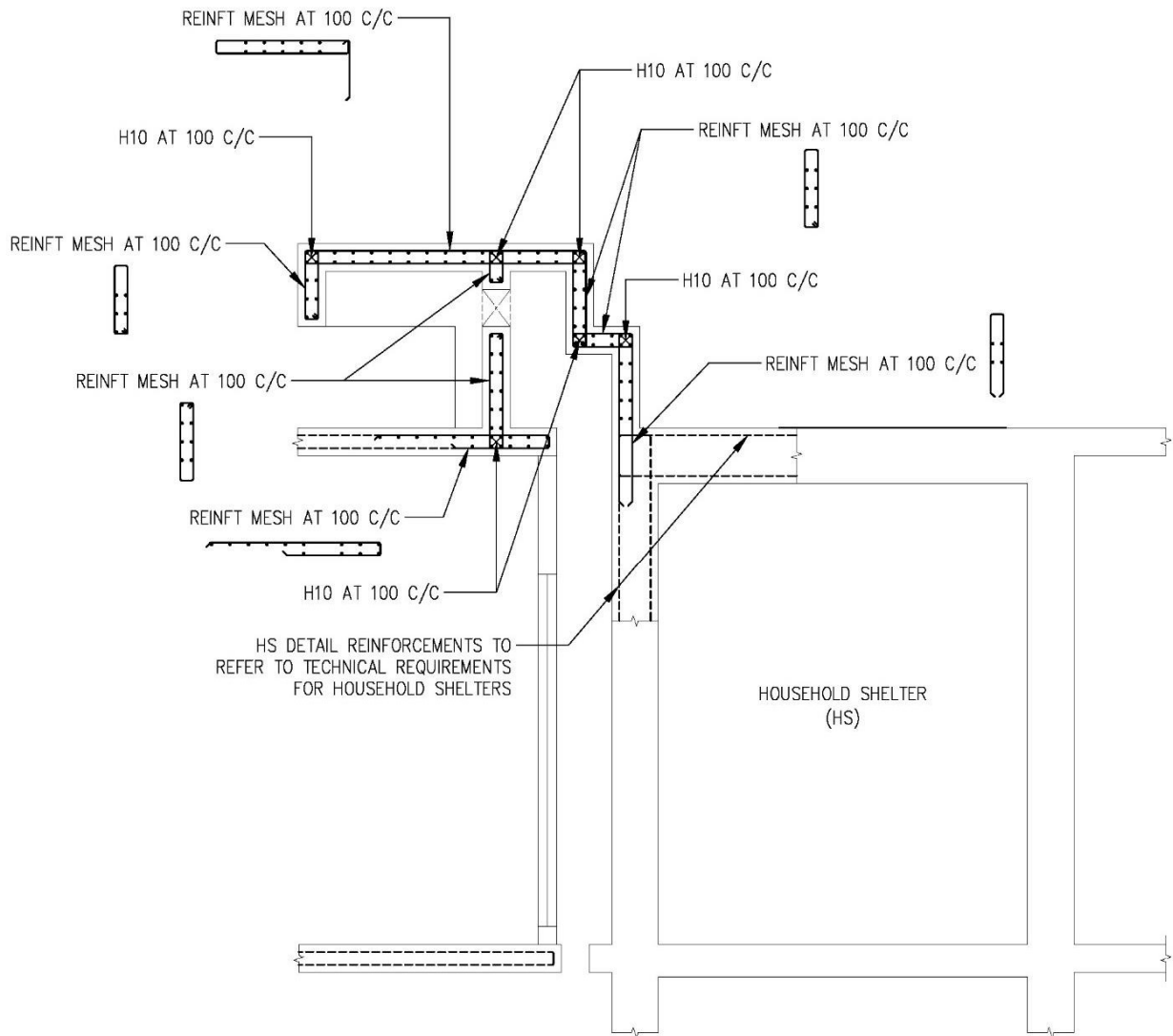

REINFORCEMENT FOR DETAIL 'A'

FIGURE 3.6.3(b) REINFORCEMENT DETAIL 'A' OF RISER ADJACENT TO HS AND ABOVE ROOF LEVEL

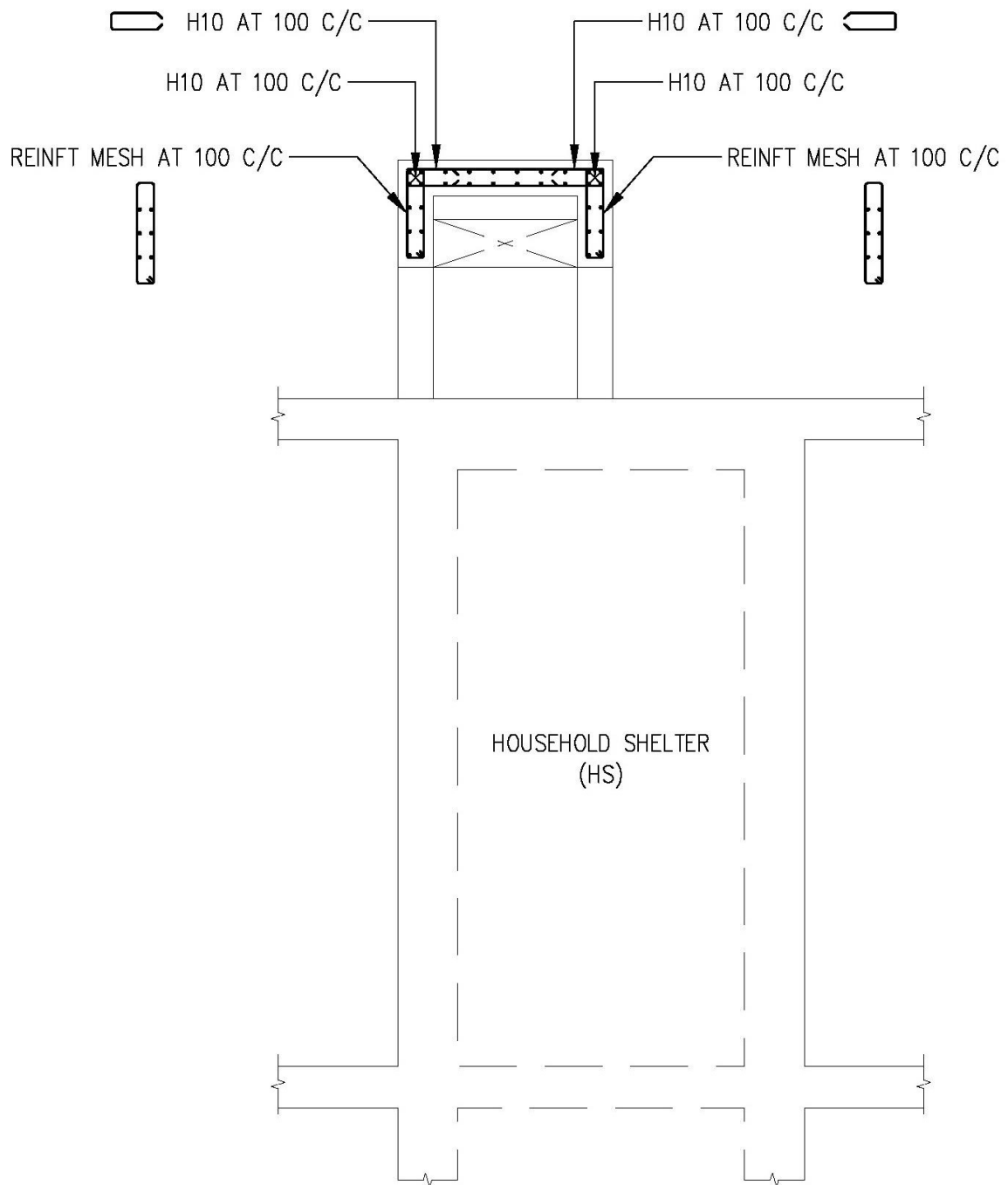

REINFORCEMENT FOR DETAIL 'B'

FIGURE 3.6.3(c) REINFORCEMENT DETAIL 'B' OF RISER ADJACENT TO HS WITH PROJECTION ABOVE ROOF LEVEL

CHAPTER 4: VENTILATION SLEEVES

4.1 GENERAL

Two 125 mm diameter ventilation sleeves shall be cast into the wall/s of each HS. Only ventilation sleeves of an approved design from approved HS steelworks suppliers shall be used.

4.2 POSITION

The position of each ventilation sleeve shall comply with the following (See FIGURE 4.2(a) and 4.2(b)):

- (a) The height of each opening of ventilation sleeve, measured from the centre of the opening to internal FFL of the HS shall be between 1900 mm and 3600 mm;
- (b) The ventilation sleeve shall be positioned such that there is sufficient clearance from any structural elements and services. The centre of the ventilation sleeve to the soffit of ceiling and the nearest face of the internal HS walls shall be at least 300 mm. In addition, there shall be a minimum unobstructed distance of at least 700 mm from the face of the ventilation sleeve openings to the nearest face of any other internal structural elements within the HS (See Figure 2.10);
- (c) Where the ventilation sleeve is placed above or adjacent to the HS door frame, the centre of the ventilation sleeve shall be at least 250 mm from the nearest edge of the door frame; and
- (d) The shortest distance between the centres of the two ventilation sleeves shall be at least 1000 mm.

4.3 ACCESSIBILITY OF VENTILATION SLEEVES

4.3.1 Clearance in front of and around Fragmentation Plate

The minimum clearance from the fragmentation plate to RC beam or structure or service shall be 50 mm. Where the RC beam or structure or service is fronting the fragmentation plate of ventilation sleeve, the clear distance between them shall be at least 500 mm. See FIGURE 4.3.1.

4.3.2 False Ceiling below Ventilation Sleeves

Where false ceilings are provided outside the HS and below the ventilation sleeves, there shall be perforated access panels of minimum size of 600 mm x 600 mm positioned directly below each ventilation sleeve. See FIGURE 4.3.2.

4.4 **FRAGMENTATION PLATE**

Each ventilation sleeve shall have a 6 mm thick stainless steel fragmentation plate mounted on the external face using 8 mm stainless steel bolts. See FIGURE 4.4(a) and (b).

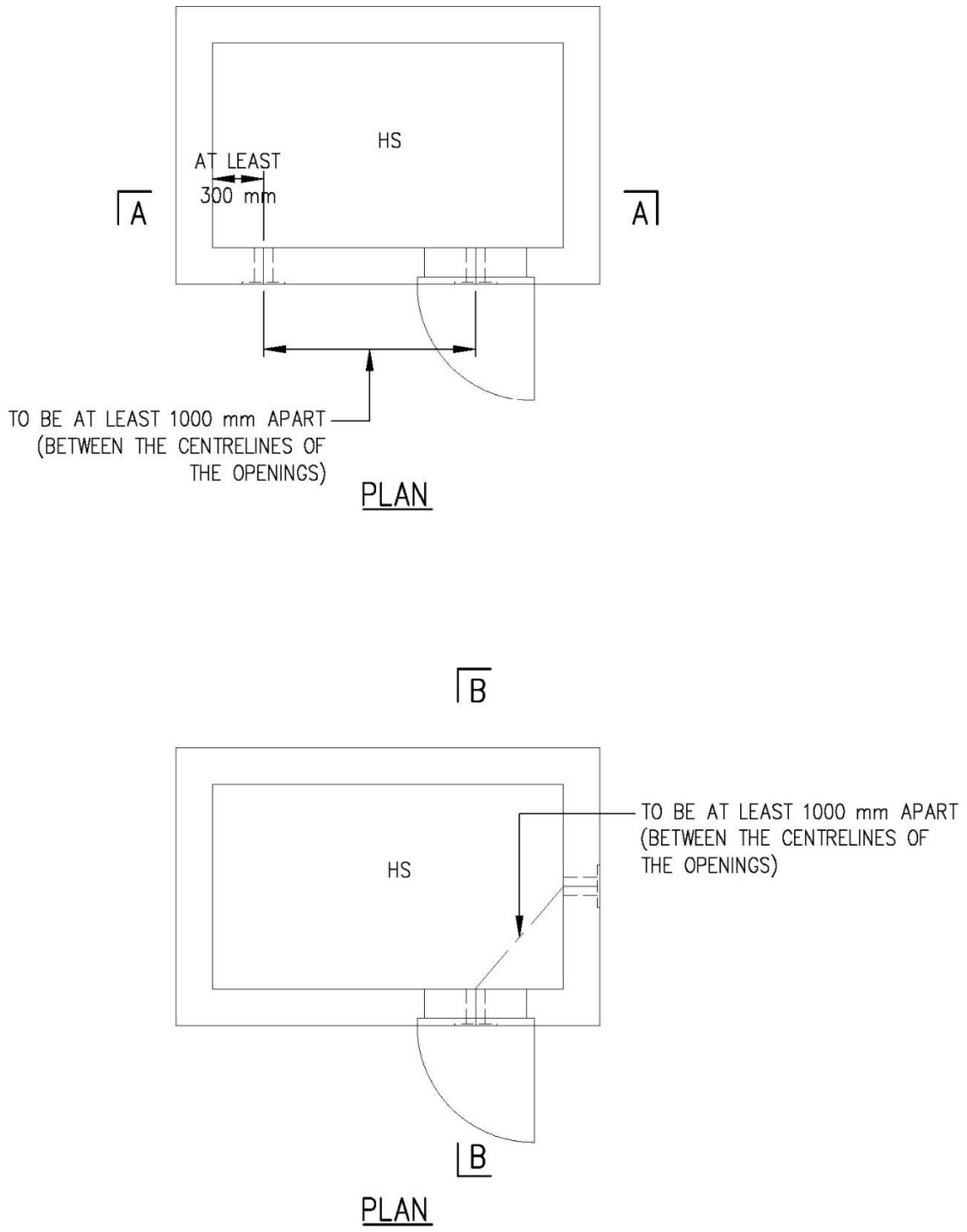
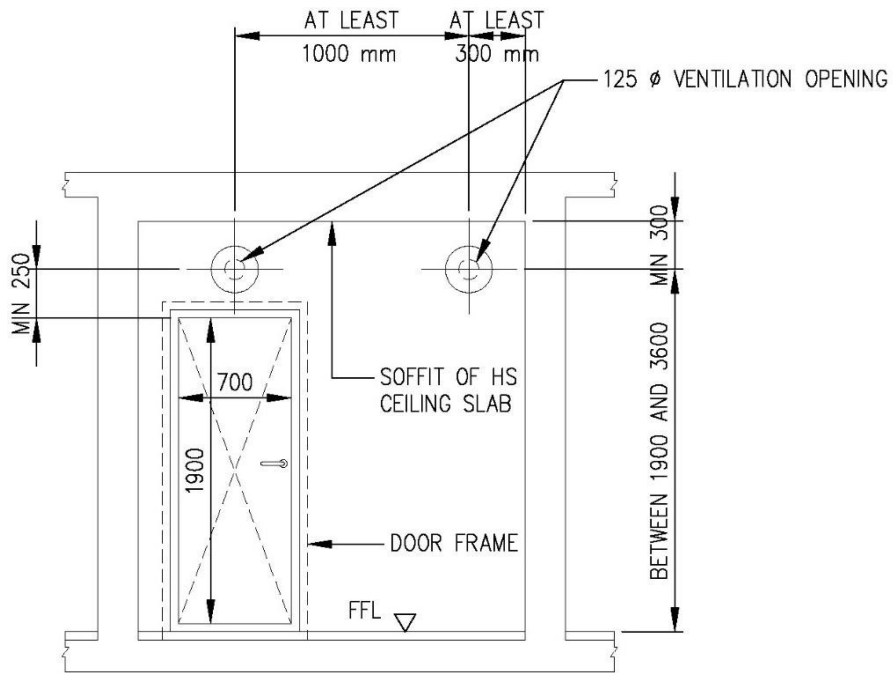
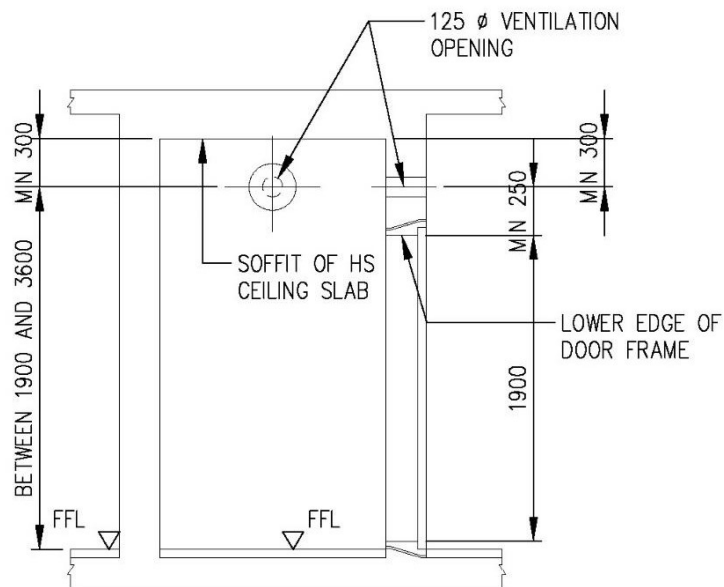

FIGURE 4.2(a) POSITION OF VENTILATION SLEEVES



SECTION A - A



SECTION B - B

FIGURE 4.2(b) SECTIONAL VIEWS OF VENTILATION SLEEVES

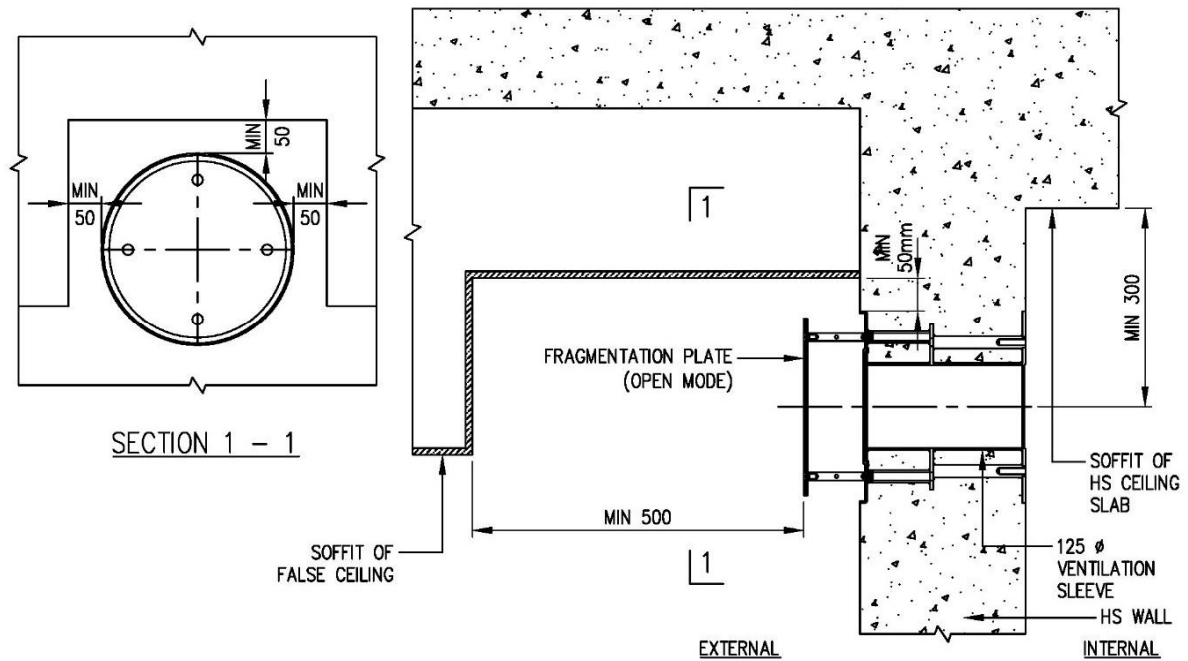

FIGURE 4.3.1 MINIMUM CLEARANCE FOR FRAGMENTATION PLATE

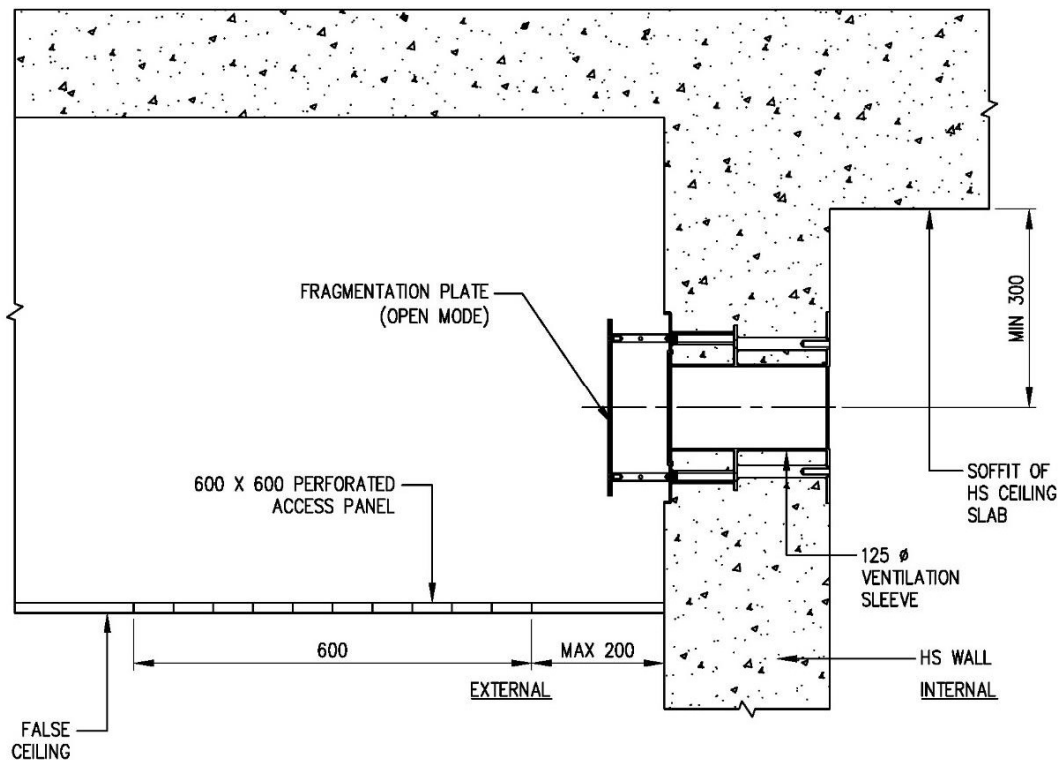
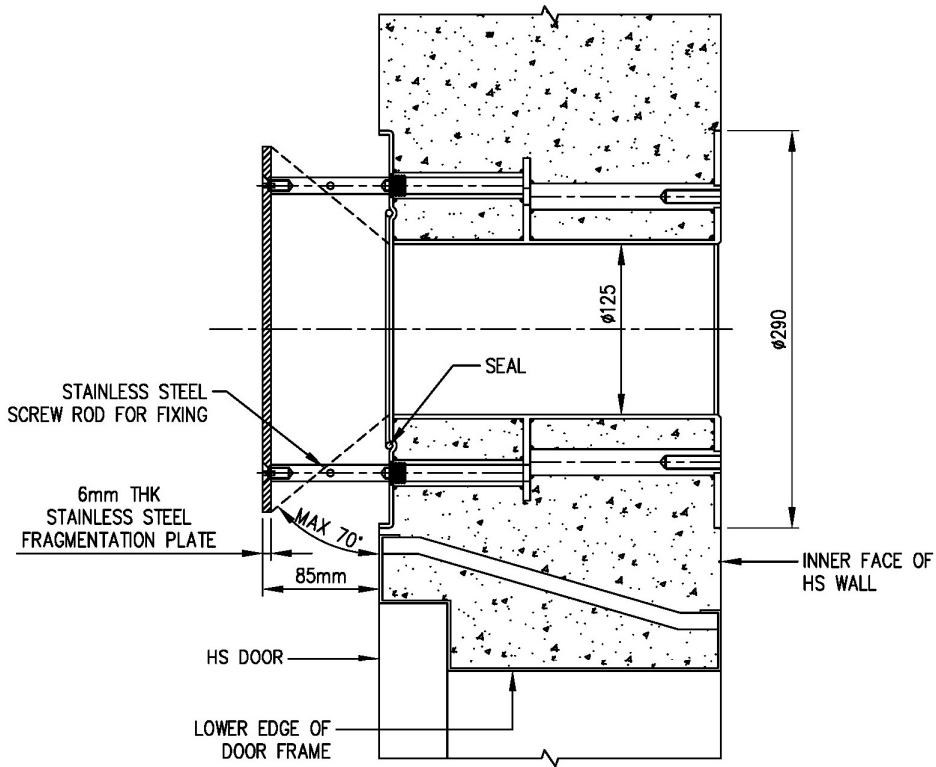

FIGURE 4.3.2 PERFORATED ACCESS PANEL BELOW VENTILATION SLEEVE



VENTILATION SLEEVE AT OPEN POSITION

NOTE:

1. DETAILS OF VENTILATION SLEEVE REFER TO SHOP DRAWINGS OF APPROVED SUPPLIERS

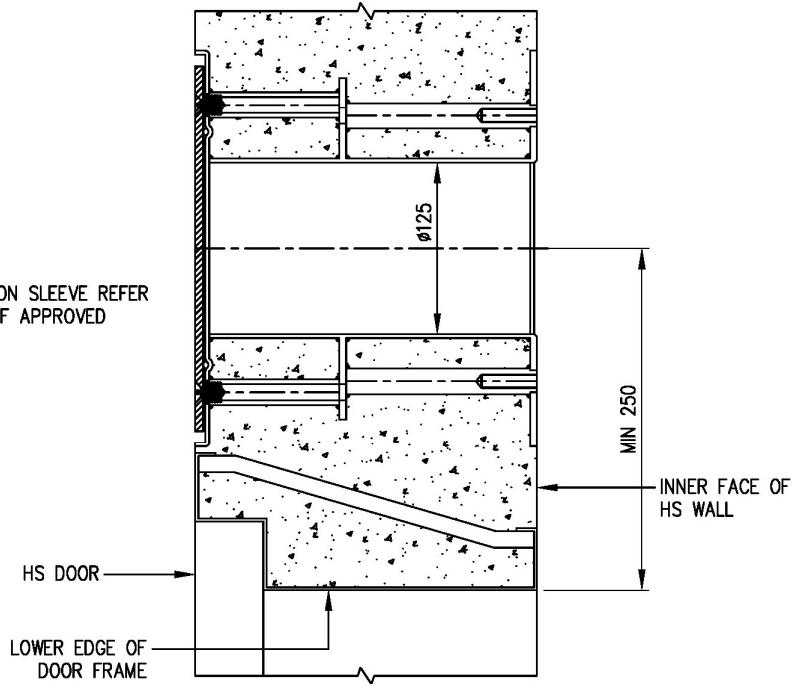

VENTILATION SLEEVE AT CLOSED POSITION

FIGURE 4.4(a) DETAILS OF VENTILATION SLEEVE AND FRAGMENTATION PLATE

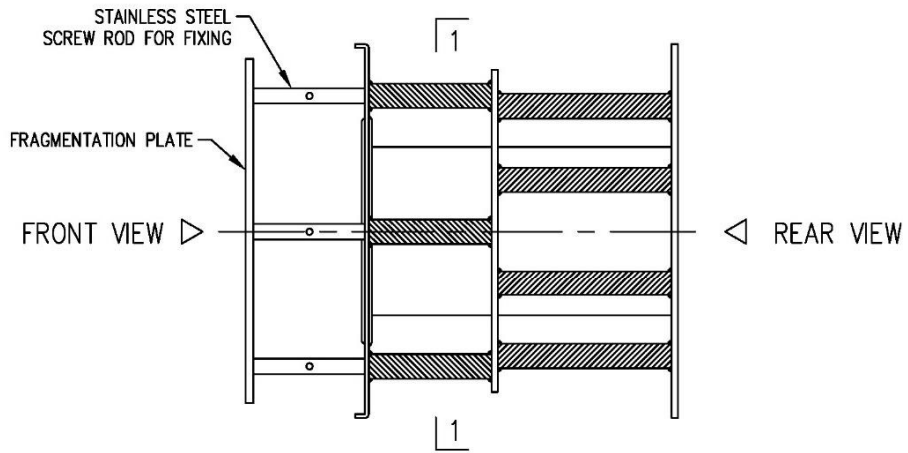

ELEVATION OF VENTILATION SLEEVE
(OPEN POSITION)

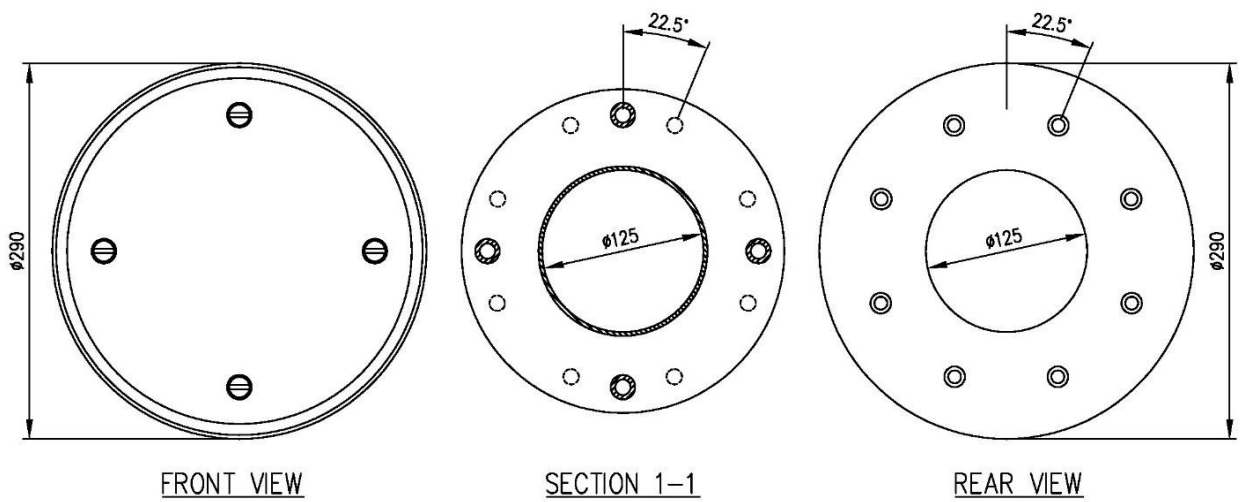

FIGURE 4.4(b) VIEWS AND SECTION OF VENTILATION SLEEVE

CHAPTER 5: HS DOOR

5.1 GENERAL

The HS door shall provide an airtight closure to the HS, and shall be designed to open outwards from the HS.

HS door frame that is cast together with the HS wall shall have single or double door rebate. See FIGURE 2.5.1(a) and FIGURE 2.5.1(b).

5.2 APPROVED HS DOOR

Only HS doors of an approved design from approved HS steelworks suppliers, and which have been certified and listed under the Product Listing Scheme shall be used.

5.3 HS DOOR NOTICE

Every HS door shall have a HS door notice affixed on its internal face (See FIGURE 5.3(a)). A sample notice is shown in FIGURE 5.3(b).

5.4 SPECIFICATION OF HS DOOR NOTICE

- (a) Manner of Application : To be affixed on the internal HS door by pressure sensitive and strong adhesive.
- (b) Special Features : Non-brittle, rub and mar resistant, storage stability and colour fastness under light.
- (c) Text, Lettering, Layout : Conform to sample notice.
- (d) Colours : Background is light yellow, lettering is black, sub-headings, border and triangular logo area are red.

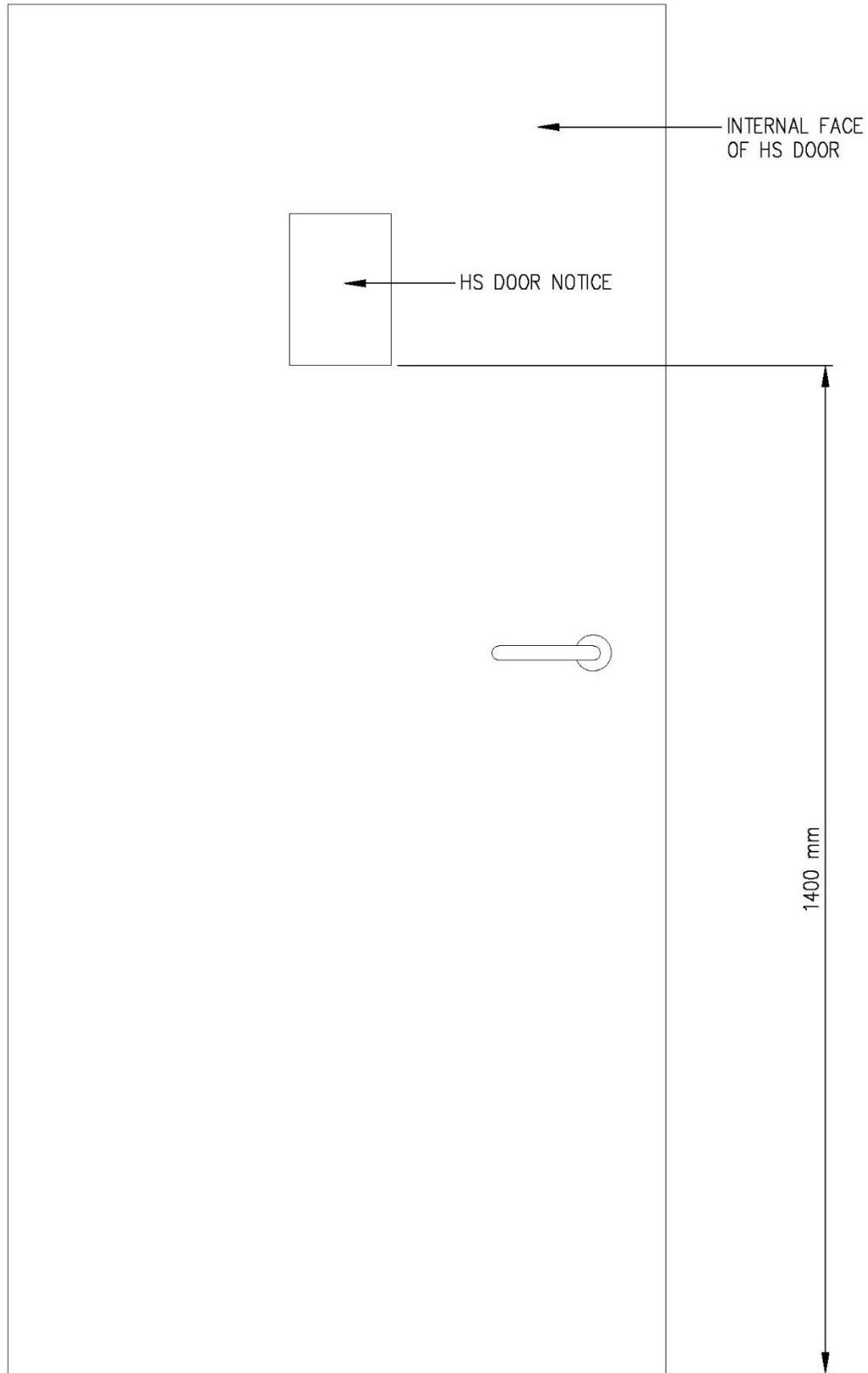

FIGURE 5.3(a) LOCATION OF NOTICE ON HS DOOR

NOTICE

This room is also a civil defence shelter provided under the Civil Defence Shelter Act 1997.

For your safety and protection,

- ▶ In the event of a fire, do not stay in the shelter. Leave the building.
- ▶ Keep every fixture installed in the shelter in good working condition at all times.
- ▶ Keep at least one of the 2 ventilation holes open to ventilate the shelter at all times.

For renovation works in the shelter,

- ▶ If this is a HDB apartment, consult the HDB branch office. If this is a private house or apartment, consult your building management corporation or the Singapore Civil Defence Force (SCDF).

During an emergency,

- ▶ Follow SCDF instructions or guidelines on what to do. These will be issued when the need arises.

Please refer to the diagram below on how to operate the door to the shelter

- ▶ Civil Defence Mode
- ▶ Normal Mode

通告

在一九九七年民防防空所法令下，这是一间受管制的室内防空所。

为了保障您的安全，

- ▶ 屋内发生火患时，立刻离开您的住所。
- ▶ 时刻确保室内防空所的设备及系统正常操作。
- ▶ 其中的一个通风窗应时刻开着。

室内防空所装修准则，

- ▶ 如住所是建屋发展局的组屋，应向建屋发展分局询问。若是私人产业则向其管理委员会或新加坡民防部队查询。

当紧急事故发生时，

- ▶ 请遵循新加坡民防部队在紧急事故发生时所发出的通告。

请参阅下列图表以了解防空门的操作，

- ▶ 民防操作法。
- ▶ 普通操作法。

NOTIS

Bilik ini adalah sebuah kubu pertahanan awam. Ini adalah di bawah Akta Kubu Pertahanan Awam 1997.

Untuk keselamatan dan perlindungan anda,

- ▶ Jika berlaku kebakaran, jangan mengambil perlindungan di dalam kubu. Tetapi keluar dari bangunan itu.
- ▶ Pastikan setiap alat yang dipasang di dalam kubu perlindungan dijaga dengan rapi setiap masa.
- ▶ Pastikan salah satu daripada dua saluran udara di dalam kubu perlindungan tidak ditutup.

Untuk kerja ubah elok di tempat perlindungan,

- ▶ Jika anda tinggal di perumahan HDB, runding dengan pejabat daerah HDB bila anda ingin menjalankan ubah elok rumah. Untuk mengubah elok rumah privet, rundinglah dengan majlis bangunan atau hubungi Pasukan Pertahanan Awam Singapura.

Di waktu kecemasan,

- ▶ Patuhi arahan atau panduan Pasukan Pertahanan Awam. Keterangan lanjut akan diumumkan bila perlu.

Sila rujuk pada gambar rajah yang tertera di bawah untuk mengetahui cara menggunakan pintu untuk ke bilik perlindungan

- ▶ Kaedah kecemasan
- ▶ Kaedah biasa

அறிவிப்பு

இந்த அறையை குடிமைத் தற்காப்பு காப்பறையாகவும் பயன்படுத்தலாம். இது குடிமைத் தற்காப்பு காப்பறை சட்டம் 1997ல் வழங்கப்பட்டுள்ளது.

உங்கள் பாதுகாப்புக்கு நீங்கள் செய்யவேண்டியவை,

- ▶ தீ ஏற்பட்டால், காப்பறையில் இருக்காதீர்கள். கட்டிடத்திலிருந்து வெளியேறுங்கள்.
- ▶ காப்பறையின் ஒவ்வொரு பகுதிகளையும் நல்ல சீர்திறையில் வைத்திருங்கள்.
- ▶ எந்த நேரத்திலும், காப்பறையில் உள்ள இரண்டு காற்றோட்ட திறப்புகளில் ஏதேனும் ஒன்றை ஓடாமல் வைத்திருங்கள்.

காப்பறை பதுப்பிப்பு வேளைக்கு செய்யவேண்டியவை,

- ▶ உங்கள் வீடு ஓர் HDB வீடாக இருப்பின், அதன் கிளை அலுவலகத்தை தொடர்பு கொள்ளுங்கள். அதே ஓர் தனியார் வீடாக இருக்குமானால், உங்கள் கட்டிட நிர்வாக கழகத்தையே அல்லது சிங்கப்பூர் குடிமைத் தற்காப்புப் படையை தொடர்பு கொள்ளுங்கள்.

அவசரக்காலத்தினாலே,

- ▶ சிங்கப்பூர் குடிமைத் தற்காப்பு படையின் குறிப்புகளை அல்லது விதிமுறைகளைப் பின்பற்றுங்கள். இவை தேவை ஏற்படும்போது வழங்கப்படும்.

கீழே சொடுக்கப்பட்டிருக்கும் படத்தில் காணப்படும் விதிமுறைப்படி காப்பறைகளின் முறையை கையாளுங்கள்.

- ▶ குடிமைத் தற்காப்பு முறை
- ▶ இயல்பான முறை

(A) Normal Mode
普通操作法
Kaedah biasa
இயல்பான முறை

(B) Civil Defence Mode
民防操作法
Kaedah kecemasan
குடிமைத் தற்காப்பு முறை

CIVIL DEFENCE
READINESS IS YOUR ONLY PROTECTION

FIGURE 5.3(b) SAMPLE HS DOOR NOTICE

CHAPTER 6: CONSTRUCTION AND COMMISSIONING

6.1 GENERAL

As the HS is designed to resist weapon effects, good workmanship is essential to achieve the designed protection level.

6.2 STRUCTURAL WORKS

The following shall be observed:

- (a) Only the non-removable type of form-tie (form-tie without through opening) to secure formwork before casting of HS wall is permitted. Upon the removal of every recessible type of plastic cones from the form-tie, the recess shall be sealed with non-shrink grout. The use of reinforcement bar as form-tie is not permitted.
- (b) To avoid bending, warping or displacement of HS door frame and honeycombing due to inadequate compaction or leakage of cementitious grout, additional precaution to ensure adequate compaction shall be taken while casting the concrete near the HS door frame.
- (c) All embedded items shall be placed and tightly secured in their intended location to ensure their stability during casting. Indiscriminate hacking and drilling of HS tower walls, ceiling slabs or floor slabs are not permitted.
- (d) The exposed surfaces of HS walls and soffit of HS ceiling slabs shall be cast with smooth concrete finish. A maximum of 2 mm thick skim coat on the internal face of the HS walls and ceiling slabs of HS is allowed.
- (e) The concrete structural elements shall be adequately compacted to ensure air-tightness. Concrete areas with segregation or honeycombing shall not be indiscriminately hacked to expose good concrete and 25mm around reinforcement bar followed by pressure grouting.
- (f) Irregularities of exposed surfaces shall not be indiscriminately hacked and plastered back.
- (g) Method statement of the remedial work on structural elements, including HS door frame, shall be approved by the Commissioner of Building Control.

6.3 **HS DOOR**

The following shall be observed:

- (a) Allowing an opening in the HS wall and later erecting the HS door frame and door leaf in this opening, followed by casting concrete around it is not permitted.
- (b) When casting the HS wall with HS door frame, a dummy door leaf of adequate design shall be placed to ensure the stability and prevent the bending, warping or displacement of the HS door frame during concreting.
- (c) The FFL of the floor slab outside the HS shall be done such that the HS door can be opened adequately for the peacetime use of the HS.

6.4 **PEACETIME REQUIREMENT OF VENTILATION SLEEVES**

For ventilation purposes during peacetime, at least 25% of total area of the two ventilation openings shall be kept uncovered.

6.5 **COMMISSIONING REQUIREMENTS**

All electrical and communication fixtures such as switch and lighting point, switched socket outlets, TV and communication line for telephony outlets including HS door notice shall be provided inside the completed HS. The service conduits with electrical cables serving the HS shall be provided prior to commissioning.

A HS is considered commissioned only if the HS passes all the following tests in one inspection:

- (a) Light penetration test of HS door – an acceptable test method to check on light penetration into the HS is to use a torch-light from the exterior of HS door. The test is considered to have passed if no light could be seen from the inside of HS.
- (b) Chalk mark test on the HS door – an acceptable test method is to apply chalk to the part of the door frame where the door seal will come into contact with when the door is closed. The test is considered to have passed if there is an unbroken and uniform transfer of the chalk markings onto the door seal when the door is closed and re-opened.
- (c) Air-tightness test of the HS – an acceptable test method is to pressurise the HS and measure the rate of pressure drop or the pressure difference between the interior and exterior of the HS. The *pressure gauge can be used for the test. The HS is pressurised by pumping air into the HS such that there is a pressure difference of 250 Pa* between inside and outside of HS. The HS is considered to have passed the test if the pressure gauge shows more than or equal to 50 Pa after 45 seconds.

The ventilation sleeves of the HS, which have been closed for the commissioning tests, shall be opened after the tests to comply with Clause 6.4 for ventilation during peacetime.

*The pressure gauge used should have a dial size with a scale of 0 to 50mm or 0 to 500 Pa. (Note: 1 mm = 10 Pa).

CHAPTER 7: PERMITTED AND NOT PERMITTED WORKS TO HS TOWER

7.1 GENERAL

Any repair or alteration or renovation works, which are likely to weaken or damage any structural elements of the HS or NS, is not permitted.

7.2 PERMITTED AND NOT PERMITTED WORKS

7.2.1 Permitted Works to HS

- (a) Laying of floor tiles bonded to wet cement mortar. The total thickness of floor finishes and screed is not to exceed 50mm.
- (b) Laying of floor skirting tiles (up to a maximum of 100 mm high) by bonding them with wet cement mortar to HS walls.
- (c) Laying of vinyl or linoleum flooring.
- (d) Applying splatter dash or equivalent to the external face of HS walls only to provide rough surface for feature wall panels or wall tiles installation.
- (e) Painting of walls, ceiling or door. In the case of HS door, owners shall not cover up or paint over the HS door notice (See Clause 5.3), locking bolts or door seal. The old paint coat on door and door frame is to be removed prior to repainting to avoid increase paint thickness resulting in difficulty in closing and opening of the door. The new paint coat must be dried up completely before closing the door as wet or damp paint will cause the door/ rubber gasket to stick onto the door frame when opening the door.
- (f) Painting on only the exterior face of the 6mm fragmentation stainless steel plate of the ventilation sleeves.
- (g) Drilling into internal face of HS walls and ceiling slabs to a depth of not more than 50mm to affix inserts and removable screws is allowed for. Fixtures such as pictures, posters, cabinets or shelves on internal face of HS walls will have to be removed by the owners within 48 hours upon notification. There is no restriction to the diameter of the non-metallic insert as long as it does not exceed 50mm in length. It is the owner's responsibility to ensure that the strength of the insert is adequately provided for the intended purpose.
- (h) Power driven nails are allowed only on external face of the HS walls to facilitate flexibility in mounting of features/ fixtures by owners.

- (i) Fragmentation plates (Clause 4.4) of the ventilation sleeves are allowed to be removed provided that the fragmentation plates and its bolts and nuts are mounted or kept together for use when needed. If the plate is to be mounted on the HS wall, it shall be done in accordance with Clause 7.2.1(g).
- (j) Closing or covering up of ventilation openings by removable aesthetic or architectural finishes is allowed, provided that at least 25% of the total area of the two openings shall be left uncovered for ventilation purposes during peacetime.
- (k) The minimum clearance from the fragmentation plate to RC beam or structure or service shall be 50 mm. Where the RC beam or structure or service is fronting the fragmentation plate of ventilation sleeve, the clear distance between them shall be at least 500 mm. See FIGURE 4.3.1.
- (l) Where false ceilings are provided outside the HS and below the ventilation sleeves, there shall be perforated access panels of minimum size of 600 mm x 600 mm positioned directly below each ventilation sleeve. See FIGURE 4.3.2.

7.2.2 Not Permitted Works to HS

- (a) Laying of wall tiles or spray of rock stone finish, cement sand finish and gypsum plastering on the internal faces of HS walls.
- (b) Laying of floor tiles using adhesive materials.
- (c) Laying of 2nd layer of tiles on floor or skirting tiles.
- (d) Installation of cornices within the HS.
- (e) Installation works with fixings using power driven nails into the internal HS walls.
- (f) Tampering with, removing or covering up of the HS door notice. The HS door notice provides important information to the occupants on the use of the HS.
- (g) Indiscriminate hacking and drilling of HS walls, floor slabs, and ceiling slabs other than drilling permitted in Clause 7.2.1(g) and 7.2.1(h).
- (h) Hacking to both internal and external face of the household shelter walls to form key for tiling.
- (i) Hacking on external face of HS wall for mounting of feature wall panels or wall tiles installation.
- (j) Modifying, changing, removing or tampering of HS door.
- (k) Modifying, altering or tampering with any part of the ventilation openings, plates and the mounting devices such as bolts and nuts.

- (l) Painting to the interior face of the 6mm fragmentation stainless steel plate of the ventilation sleeves, the ventilation sleeves, “O” ring rubber gaskets and the four or eight numbers of stainless steel bolts which hold the steel plate to the sleeves.

7.2.3 Not Permitted Works to NS

Indiscriminate hacking and drilling of NS walls, floor slabs and ceiling slabs are not permitted.



SCDF
The Life Saving Force

**HQ Singapore Civil Defence
Force 91 Ubi Avenue 4,
Singapore 408827**

Building and Construction  Authority

We shape a **safe**, **high quality**, **sustainable** and **friendly** built environment.

**52 Jurong Gateway Road
#11-01, Singapore 608550**

